

Presentation-style conferences for up to 14 languages, where a floor and a single relay language are used.

# IC-2

## Interpreter Control Console



The Williams Sound IC-2 is an audio control center for simultaneous interpretation of one or more languages. As a stand-alone unit, it allows one or two interpreters to monitor floor or relay sources, activate microphone inputs, and route the interpretation signal to one of two language groups. Ideal for presentation-style conferences for up to 14 languages, where a floor and a single relay language are used. Can be used with Williams Sound FM, IR and Digi-Wave™ transmitters for portable or fixed installations. Designed to meet international standards for portable interpretation consoles.

### Features

- CAT5 audio bus offers simplified cabling, easy cascading to support additional interpreters.
- Built-in distribution amplifier and mini mixer reduce the need for external equipment and greatly simplify setup.
- Floor language feed-through
- Interlocking microphone and CH2 (relay) output functions
- Soft-touch buttons provide for smoother, quieter operation
- Enhanced flexibility, providing each interpreter with multiple microphone and headset options
- Individual volume and tone controls ensure optimal listening levels
- Five-year warranty

# IC-2 Interpreter Control Console

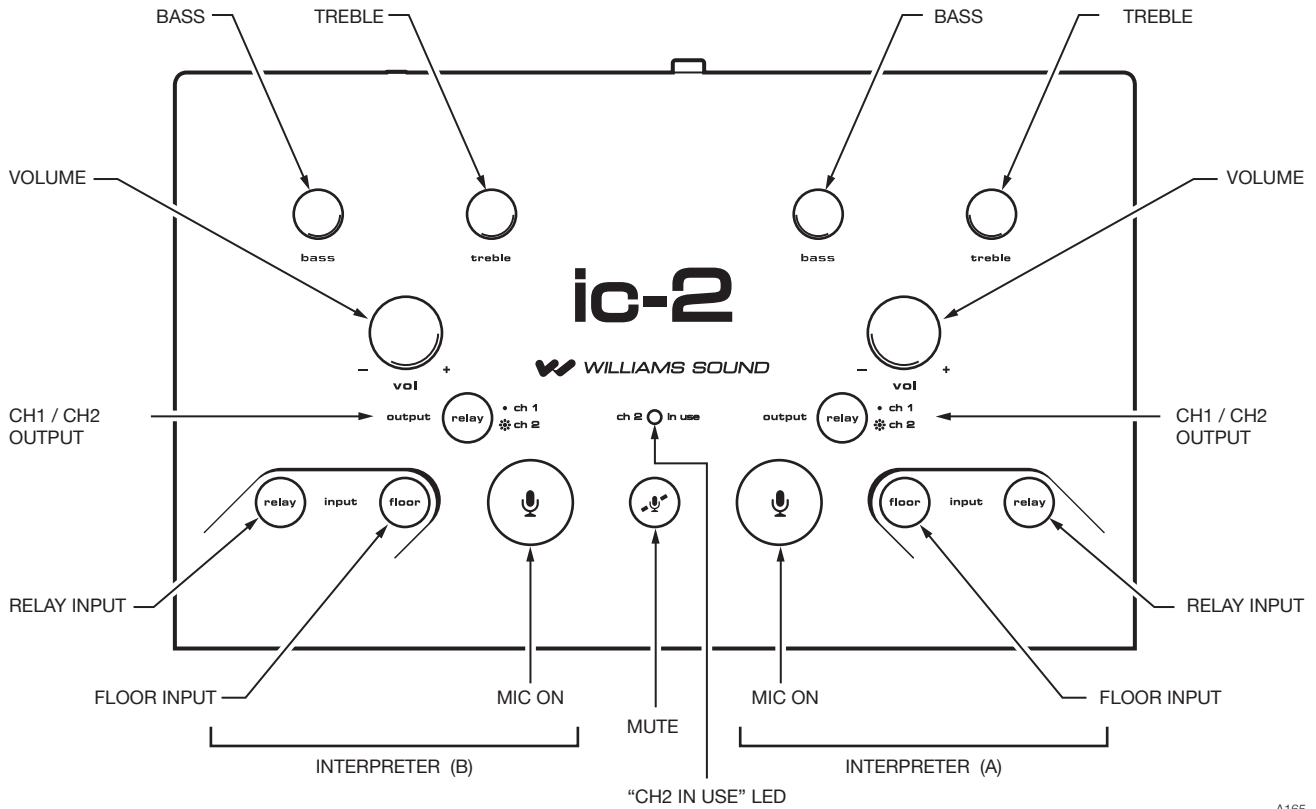

A165

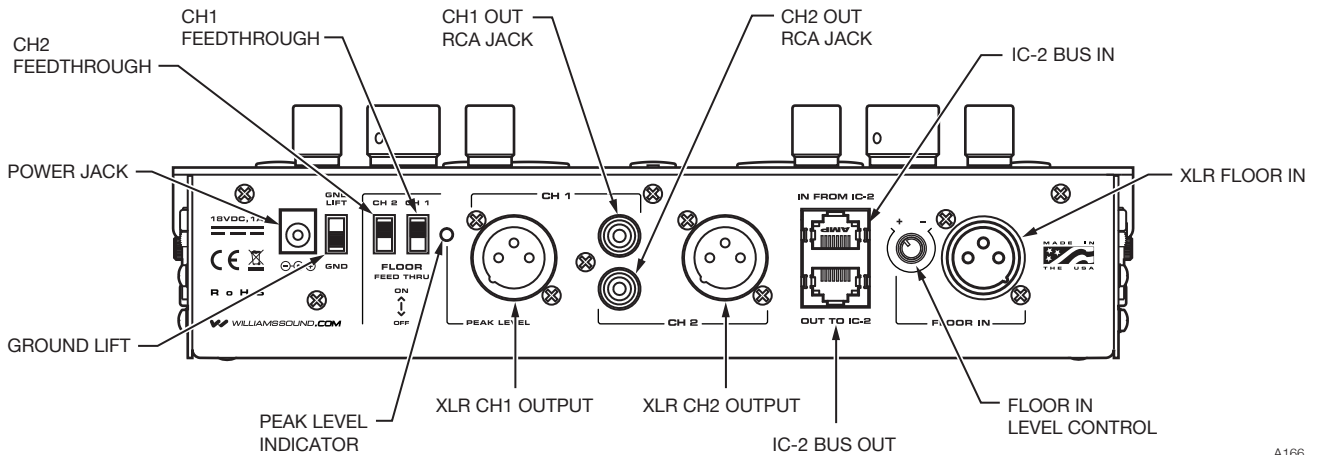

A166

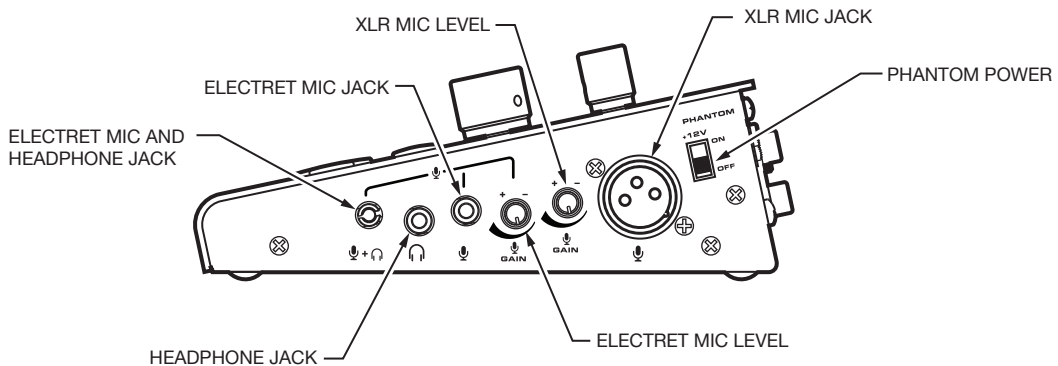

A167

# IC-2 Interpreter Control Console

## Signal Schematics

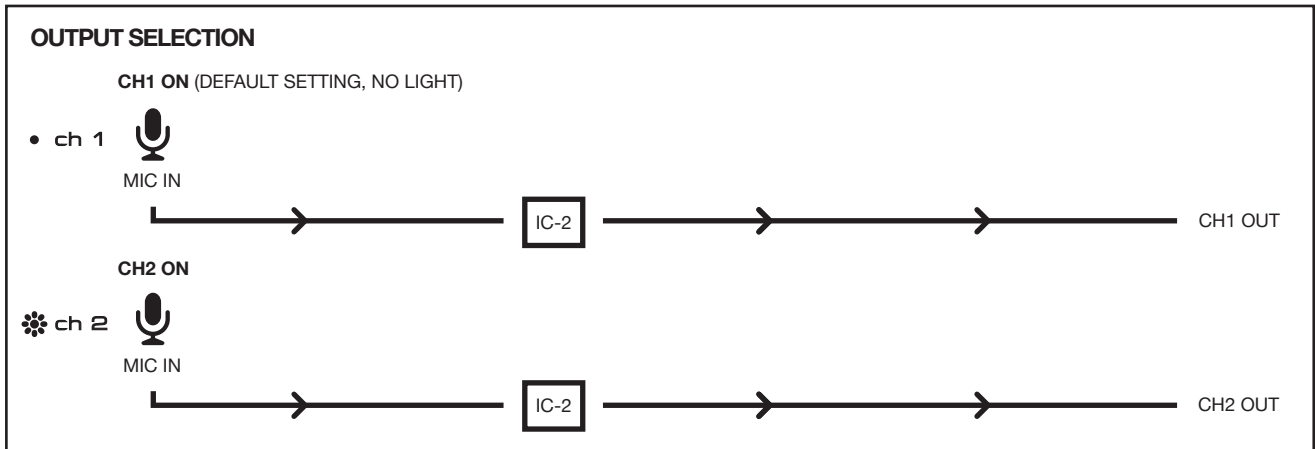
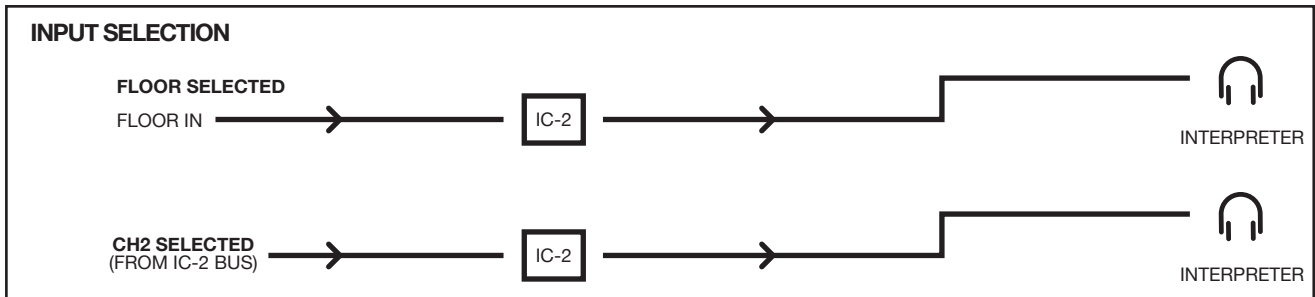
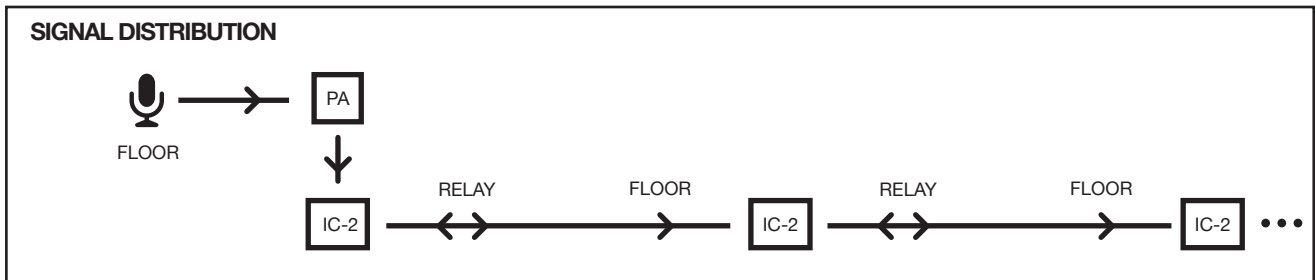

A168

# IC-2 Interpreter Control Console

## IC-2 Specifications

Dimensions/Weight/Color	10" (25.4cm) x 6.35" (16.1cm) x 2.45" (6.2cm) / 3.4 lbs (1.5 kg) / Black and Silver
Power	External Power Supply, 18VDC Desktop Style Switching Inverter, 110-240VAC, 50-60Hz, 1A
<b>INPUTS / OUTPUTS</b>	
Floor In	3-pin XLR female jack, balanced (or unbalanced) input with 24k $\Omega$ differential input impedance, max balanced input is +19dBu
IC-2 Bus In / Out	CAT5 8p8c RJ45 female receptacle, distributes balanced line level Floor and Relay audio to another IC-2
XLR Microphone Inputs	3-pin XLR female jack, balanced (or unbalanced) input. Switchable 12VDC simplex power. Variable gain of 58 dB, 2.4k $\Omega$ balanced input impedance, maximum balanced input is +19 dBu
3.5mm Microphone Inputs	Stereo 3.5 mm TRS phone jack, pink, and stereo 3.5mm TRRS phone jack, black, unbalanced (r,s) for electret condenser mics, variable gain of 40dB. Bias is 3.7VDC through 2.7k $\Omega$
3.5mm TRRS Headphone Output	3.5mm TRRS phone jack, Tip = Left, Ring 1 = Right, Ring 2 = GND, Sleeve = Mic. 40mW max power into 32 $\Omega$ stereo headset.
3.5mm Headphone Output	3.5mm TRS phone jack, mono or stereo headphone, 8 $\Omega$ minimum. 190mW max power into 32 $\Omega$ stereo headset.
CH1 Out, CH2 Out	3-pin XLR male jack, balanced output. Max output is +19dBu into 600 $\Omega$ balanced load impedance.
RCA Jacks	Red: RCA jack for recording and CH1 audio, Interpreter audio only, no feedthrough. White: RCA jack for recording CH2 audio.
<b>CONTROLS</b>	
Volume	Left and Right rotary, controls headphone volume
Bass and Treble Tone	Left and right rotary with center detent, controls headphone bass and treble tone levels.
Mute	Push button, backlit red, mutes left and right mics while pressed.
Mic On	Push button, backlit bright red, activates microphone. Right and left Mic On buttons are interlocked; mic can only be turned on if the other is off.
Floor Input, Relay Input	Push buttons, backlit blue, select listening language group. Listening modes are either/or: turning one on disables the other.
CH2 Output	Push button, backlit yellow, selects microphone output language group: light on = CH2 Out, light off = CH1 Out.
Gain Adjust	Rotary gain pots control level of microphone and Floor audio.
Phantom Power	Slide switch enables 12VDC Simplex power to XLR microphone.
CH1 Feedthrough	Slide switch enables Floor feedthrough to Norm Out XLR jack.
CH2 Feedthrough	Slide switch enables Floor feedthrough to Relay Out XLR jack.
Ground Lift	Slide switch disconnects Chassis and Audio Grounds internal to the console.
<b>INDICATOR</b>	
Peak Level Indicator	Green LED on back panel indicates optimal audio output level on Norm Out XLR when blinking.
CH2 Output in Use Indicator	Yellow LED on front panel indicates when CH2 is in use.
<b>AUDIO OUTPUT</b>	
Frequency Response	45Hz to 20kHz, +0/-3dB re: 1kHz with flat bass/treble
Distortion at 1kHz	<0.5% THD @ full power
Signal to Noise Ratio	>82dB @ 1kHz
Crosstalk Attenuation	>63dB @ 1kHz
Tone Controls	Bass: +12dB Boost or -12dB Cut @ 100Hz Treble: +12dB Boost or -12dB Cut @ 10kHz
Approvals and Declarations	CE, FCC, Industry Canada, RoHS, C-Tick, CB
Warranty	5 years, parts and labor (90 days on accessories)

# IC-2 Interpreter Control Console

---

## Architectural and Engineering Specifications:

The IC-2 is an audio control center powered by an 18VDC universal (100 – 240 VAC) power supply. It shall be housed in a black and grey steel enclosure 10" x 6.35" x 2.45".

### Top

The IC-2 shall have individual rotary volume and tone controls for two interpreters (L & R). Input and output selection is selected with soft touch buttons for smooth quiet operation. The console shall have two selectable listening modes (blue, relay and floor) and two selectable output modes (yellow, CH1 and CH2). The unit shall have two microphone select buttons (red when activated) and microphone (push and hold) for mute.

### Rear

Each unit shall have an RJ-45 input and output for interconnection to additional IC-2s via CAT5 audio bus cable eliminating the need for additional distribution amplifiers. It shall have an XLR floor in jack with gain control. It shall have XLR and RCA CH2 and CH1 outputs. It shall have switchable CH1 and CH2 selection and ground lift capability.

### Sides

It shall have one XLR audio input jack for microphone with its own rotary gain control and switchable 12V power supply for each interpreter (L & R). It shall have 3.5mm microphone input (with rotary gain control) and 3.5mm headphone output jacks. Each side shall also have a 3.5mm combination headset jack for use with iPhone style headsets.

This unit shall be the Williams Sound model IC-2.

### Domestic Sales

Williams AV  
10300 Valley View Rd  
Eden Prairie, MN 55344  
Ph: 800-328-6190 / 952-943-2252  
FAX: 952-943-2174  
Email: [info@williamsav.com](mailto:info@williamsav.com)  
Web: [www.williamsav.com](http://www.williamsav.com)

### International Sales

International Sales Department  
Williams AV  
10300 Valley View Rd  
Eden Prairie, MN 55344 USA  
Phone: +1 952 943 2252  
Fax: +1 952 943 2174  
Email: [info@williamsav.com](mailto:info@williamsav.com)  
Web: [www.williamsav.com](http://www.williamsav.com)

**WILLIAMS AV**  
[info@williamsav.com](mailto:info@williamsav.com) / [www.williamsav.com](http://www.williamsav.com)  
800-843-3544 / INTL: +1-952-943-2252