

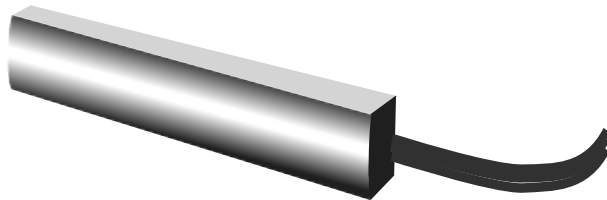

INSTALLATION INSTRUCTIONS

DL85

***Dinky Link™ Surface Mount
Plasma \ LCD \ LED \ CFL Friendly
IR Receiver***



DESCRIPTION

These small IR receivers have been designed for mounting in very small spaces. They may be mounted under shelf edges, cabinet ledges, in wall speakers, etc. – anywhere an inconspicuous appearance is desired. The high sensitivity of these receivers allows placement behind speaker grilles and still receive IR commands up to 80 feet away*.

FEATURES

- Wire channel for clean installation.
- System testing red-talk-back LED.
- Includes 3-Terminal Block for easy extension to remote room locations.

SPECIFICATIONS

- Infrared carrier frequency bandwidth: 30 - 60 kHz.
- Reception range: Up to 80 feet.*
- Reception angle: +/- 60 degrees.
- Cable requirements: See "INSTALLATION" below.
- Max. Transmission length: 1 mile using 18 gauge wire.
- Maximum current output: 100mA.
- Drives IR emitters through Xantech Connecting Blocks, Controllers, etc.
- Dimensions: 2.55" x 0.55" x 0.35" (65mm x 14mm x 9mm).
- Power requirements: +12VDC, 10mA.

* Depending on remote control output strength and ambient conditions.

MOUNTING

The IR receiver can be mounted to any flat surface, using the two-sided adhesive tape supplied. Two screws are included for mounting the 3-terminal block provided with the IR receiver.

An additional feature is a wire channel on the rear of the surface mount IR receiver. This will give the installer the ability to provide clean wire dressing in any direction.

INSTALLATION

IR RECEIVER CABLE WIRING

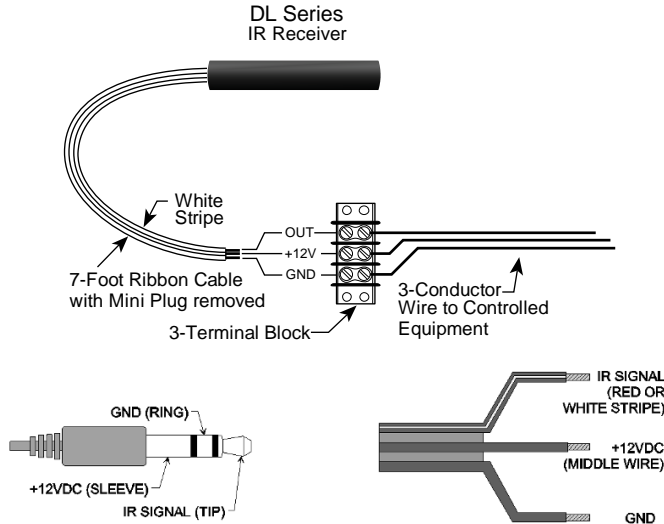

REMOTE ROOM APPLICATION

One application is to locate the IR receiver in a remote room. This will give the end-user the ability to control audio/video equipment from a location where the remote control no longer has the ability of direct line-of-sight.

The IR receiver will need the 3.5mm stereo type mini plug removed to extend the wire run to the connecting block. A 3-terminal block is supplied to connect the IR receiver to the connecting block with a 3-conductor inter-room cable in between. The 3-conductor inter-room cable (24 gauge up to 200', 22 gauge up to 600', 20 gauge up to 2000', 18 gauge up to 5000'), is run to the main room.

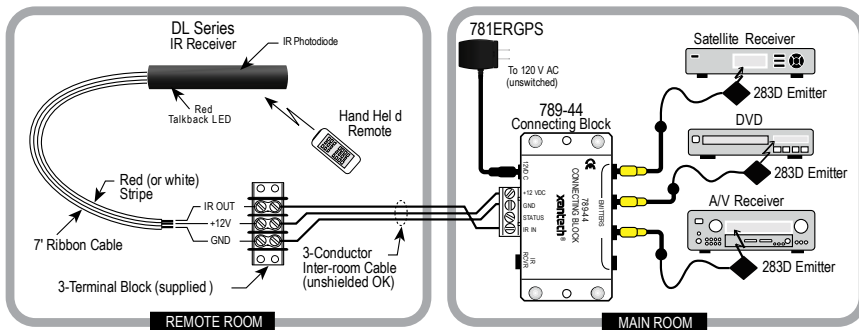

Input connections must be made as illustrated. To extend the emitter wires to a more distant location, you may splice in 2-conductor wire, in the wire gauges mentioned before, as needed.

While it is possible to make wired connections without the connecting block, it is not recommended. The connecting block reduces installation time, helps to eliminate errors, allows easy troubleshooting and permits easy system upgrades later, if needed.

LOCAL SYSTEM APPLICATION

Another application is to locate the IR receiver in a central location, such as the TV, video screen and/or a speaker. The audio/video equipment can then be hidden inside a cabinet or located away from the front of a room. This will give the end-user the ability to direct a remote control to one central location and not have to worry about aiming to the respective device to be controlled.

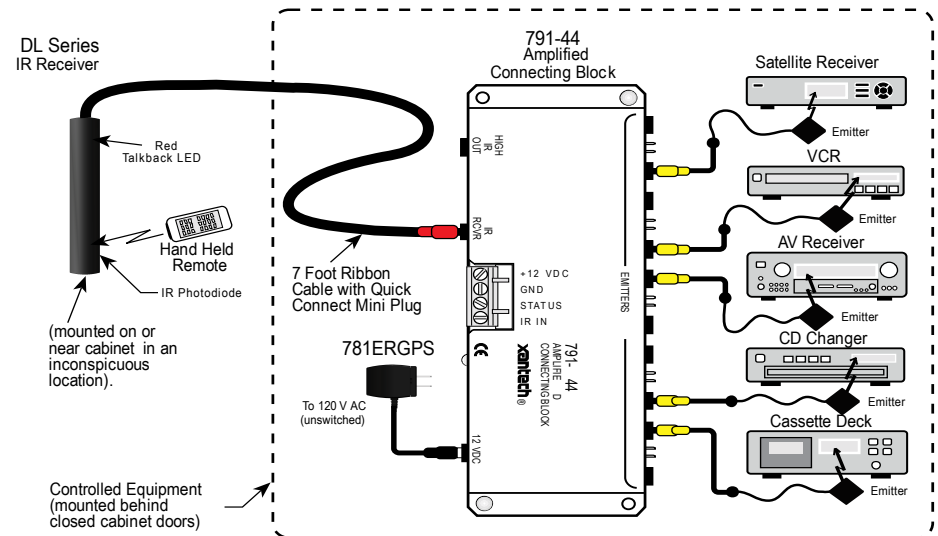

The IR receiver is in close proximity to the audio/video equipment, no wiring extension should be required so long as the connecting block is within reach of the 7-foot cable. The 3.5mm stereo type mini plug is connected to the "IR RCVR" jack on the Xantech Connecting Block.

PLACEMENT

The IR receiver should be located so that it is not directly facing a light source such as lamps or displays (standard, LCD, and Plasma). When mounted near a display, it should be flush to the display and away from light reflections that may occur.

TROUBLE SHOOTING:

1. Perhaps the most common problem you may encounter is stray IR (infrared) or RF (radio frequency) interference preventing proper operation of the controlled equipment.
 - Fluorescent, Compact Fluorescent, Neon or Halogen lights, Neon Art, and light dimmers.
 - Direct or reflected sunlight.
 - Infrared security sensors (active types).
 - RF radiation from TV sets that may be close to the Dinky Link IR Receiver.
2. You can confirm the source of the interference by temporarily turning off TV sets, isolating the Dinky Link IR Receiver from all sunlight and turning off all lights, light dimmers and Infrared security systems. Then check to see if the Dinky Link IR Receiver operates the component.
 - Sometimes interference will cause the red Talk-Back LED on the front of the Dinky Link IR Receiver to blink dimly, intermittently, or continuously.
 - The Talk-Back Led should only blink when you are sending infrared commands to the Dinky Link IR receiver from a remote control.
 - It may be necessary to move either the interfering source of the Dinky Link IR Receiver to achieve proper operation.
3. If the Talk-Back LED or the 283D Emitters do not blink when you are sending IR commands to the Dinky Link IR Receiver from a remote control, check the following:
 - Make sure the power supply is plugged securely into a live AC electrical outlet.
 - Be sure the stereo mini plug of the Dinky Link IR Receiver is plugged into the "IR RCVR" jack on the CB12 Connecting Block, not into the "OUT" jack.
 - Check to see that all the mini plugs are properly seated into the mini jacks on the CB12 Connecting Block.
4. If the 283D Emitters blink, but the component does not respond, reposition the 283D Emitter(s). They may not be located directly over the component's infrared receiving "window". Consult the owner's manual of the unit or the manufacturer for the exact location of the infrared "window".

Limited Warranty

Xantech® warrants its products to be free of defects in materials or workmanship. This is a Limited Lifetime warranty from the date of purchase by the original consumer. Any products returned to Xantech and found to be defective by Xantech within the warranty period will be repaired or replaced, at Xantech's option, at no charge. Xantech will not be responsible for the actual cost of installation or removal of the product, nor for any incidental or consequential damages. Some states do not allow the exclusion or limitation of incidental or consequential damages, so the above limitation may not apply to you. This warranty gives you specific legal rights. You may have additional legal rights that vary from state to state.

Xantech Corporation

13100 Telfair Ave., Sylmar CA 91342 | Xantech.com

Installation Instructions, DL85 © 2009 Xantech Corporation
Document # 08905257B

This document is copyright protected. No part of this manual may be copied or reproduced in any form without prior written consent from Xantech Corporation. Xantech Corporation shall not be liable for operational, technical, or editorial errors/omissions made in this document.