

Model Series 200LVC Volume Control w/wall plate

Easy-install volume controls with rotary switch provide precise level adjustment of single or multiple speaker lines.

Features

- 200W power rating
- 3dB per step attenuation with two positions of 6dB prior to "Off"
- Easy-connect, phoenix style plug-in screw termination strips for pre-wire convenience; wire capacity up to 14-gauge.
- Two-gang standard or Decora® style wall plate
- Rotary switch
- For applications specifying a durable non-corrosive wall plate
- Mounts in two-gang E.O. box with minimum depth requirement of 2.5" including mud ring (if used).

A&E Specifications

The volume control shall be Lowell Model _____ with 200W power rating, 3dB per step attenuation and two 6dB positions before "Off." The control shall have plug-in termination for up to 14-gauge wire for 70V or 100V input connections from the amplifier and 70V or 100V output to the speaker/transformer assemblies. The plate shall be two-gang _____ (standard, Decora®) style with _____ (stainless steel, stainless steel & black) finish. It shall feature a black rotary knob. The volume control shall mount in a standard two-gang E.O. box with minimum depth of 2.5" including mud ring, if used. The box is not included.



Standard Two-Gang Plate
Stainless Steel



Decora Style Two-Gang Plate
Stainless Steel & Black

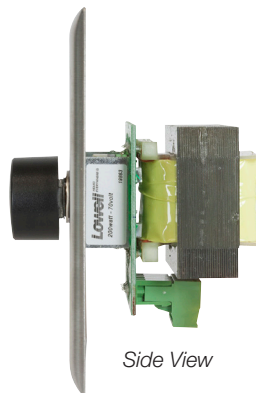

Side View

Model No. Summary

Model No.	Power Rating	Type	Switch Type	Switch Positions	Attenuation * Step / Total	Two-Gang Plate Style	Plate Finish
200LVC	200W	auto-trans	rotary	10-off	3dB / 33dB	standard	stainless steel
200LVC-DSB	200W	auto-trans	rotary	10-off	3dB / 33dB	Decora®	stainless steel & black

* Two steps of 6dB each before "Off"

Wiring & Schematics

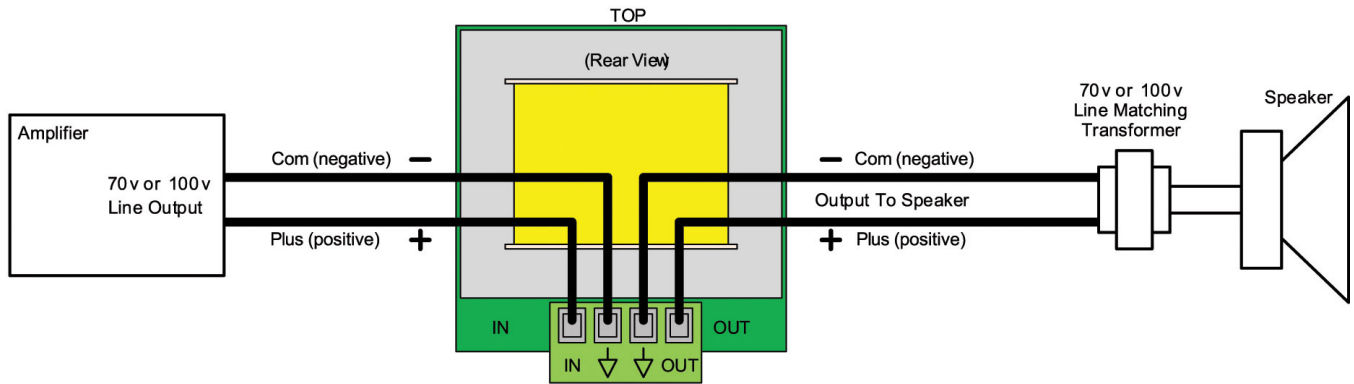

Note: Units manufactured before May 2014 had terminals located at the top. When connecting either version be sure to observe INPUT/OUTPUT and polarity designations.

