

User's Guide

for Echo™ I Desktop

Thunderbolt™ 3 to PCIe® Card Expansion System

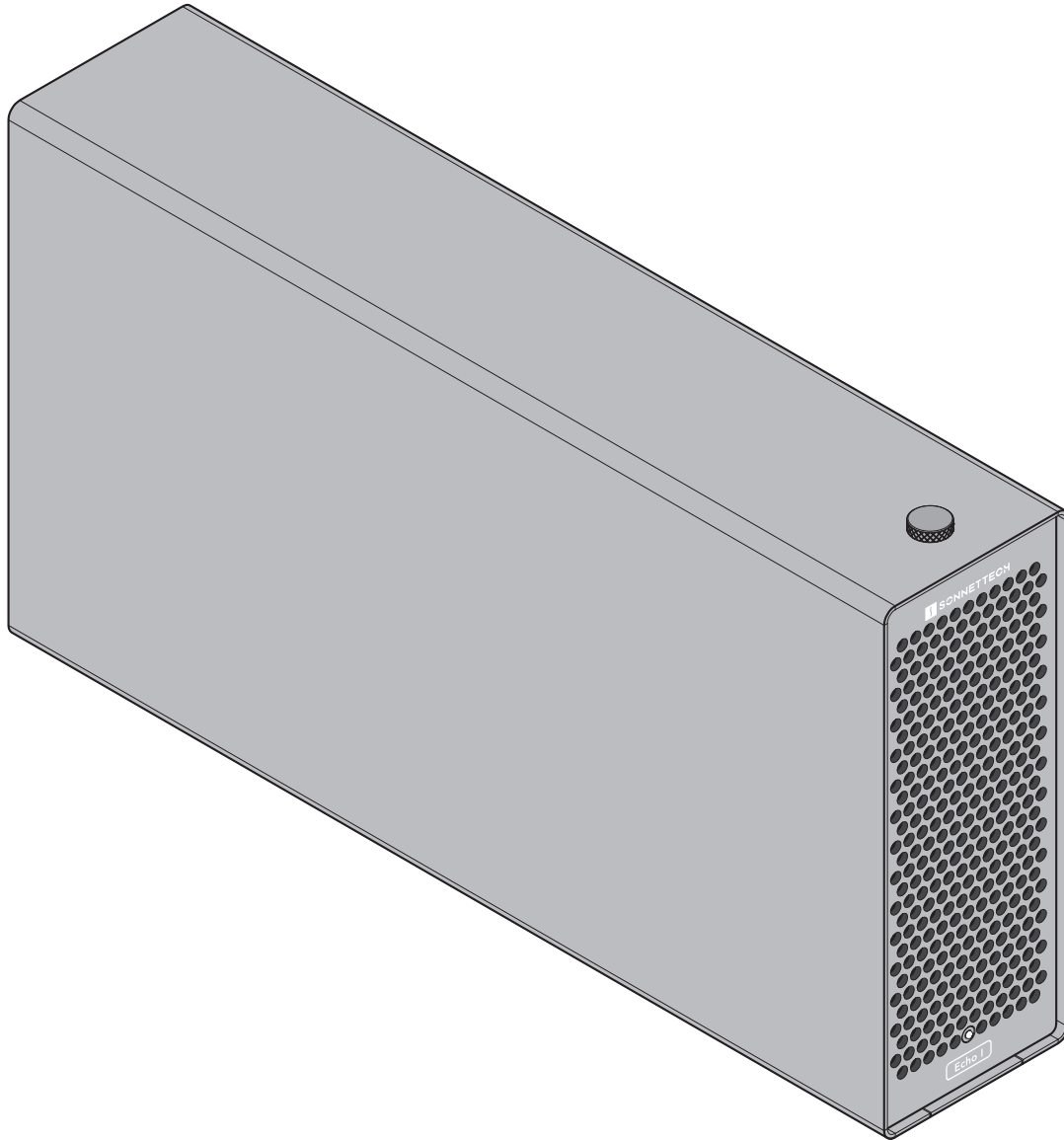

Support Note: This document was up to date at the time of printing. However, changes to the hardware or software may have occurred since then. Please check the Sonnet website for the latest documentation.

1. Go to www.sonnettech.com/support/kb/kb.php
2. Navigate to and click the Echo I Desktop link.
3. Click the Manual link.
4. Click the Echo I Desktop User's Guide [English] link and then check the Document Version information. If the version listed is later than this document (**revision C**), click the Download Now button for the latest version.



THUNDERBOLT™



For
Windows



Contents

1	Introduction and System Requirements	1
	Introduction	
	Mac Compatibility	
	Windows Compatibility	
	Linux Compatibility	
	PCIe Card Usage System Requirements	
2	Echo I Desktop Description	2
	Exterior	
	Echo I Module (Inner Assembly)	
	Thunderbolt 3 (40Gbps) Cable	
	Thunderbolt 3 Connector Retainer Clip	
3	PCIe Card Installation and System Setup Steps	4
4	Complete Setup and Configuration	7
	Setup and Configuration Steps—Mac Users	
	Setup and Configuration Steps—Windows Users	
5	Tips, General Information, and Known Issues	9
	Tips, General Information	
	Known Issues	
6	Precautions, FCC Compliance, and Support Information	10
	Safety Precautions	
	Warnings	
	FCC Compliance	
	Contacting Customer Service	

Chapter 1 – Introduction and System Requirements

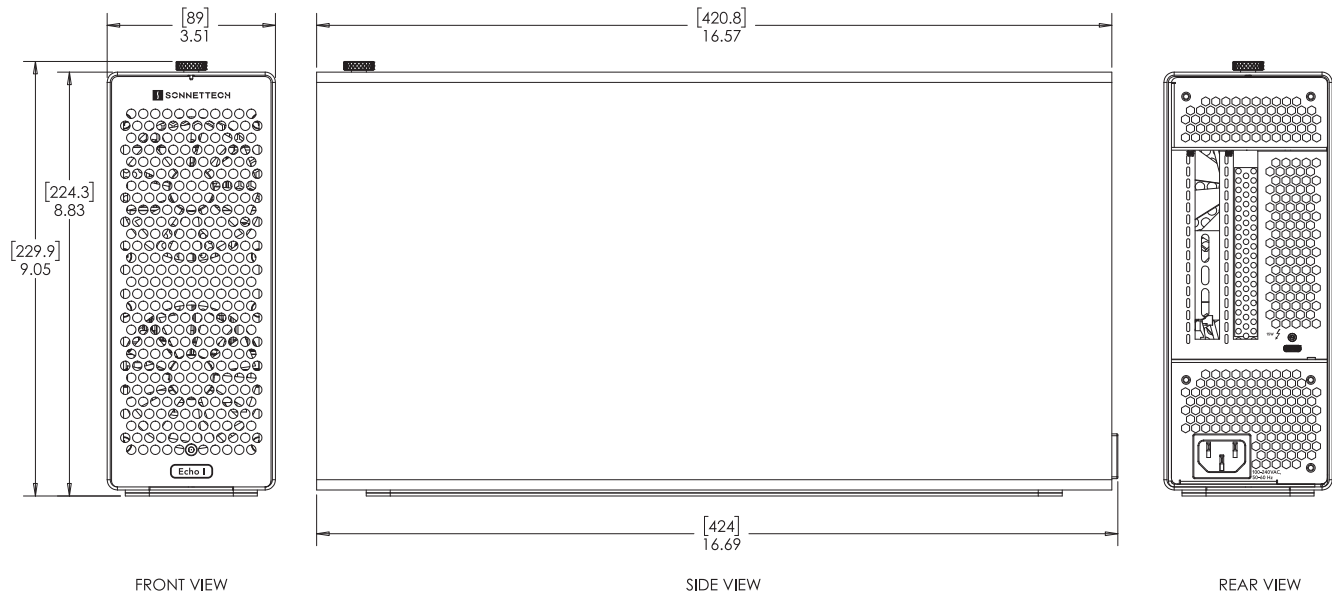

Introduction

Congratulations on your purchase! The Echo I Desktop is a Thunderbolt 3 expansion system for PCIe cards. Through its PCIe slot, you may connect an adapter card to a computer with Thunderbolt ports to expand its capabilities and add connectivity beyond what's offered through its native ports.

Mac® Compatibility

- Mac (M1, M2, M1 Pro, M1 Max, M1 Ultra) computers with PCIe cards that have M1 processor-compatible drivers
- Mac (Intel®) computers with Thunderbolt 3 ports
- Mac computers with Thunderbolt 2 or Thunderbolt ports via an Apple Thunderbolt 3 (USB-C) to Thunderbolt 2 Adapter plus Thunderbolt cable (both sold separately)
- macOS® 10.12.6+

Windows® Compatibility

- Windows computer with Thunderbolt 4 or Thunderbolt 3 ports
- Windows 11 and Windows 10

Linux® Compatibility

- Linux computers with Thunderbolt 4 or Thunderbolt 3 ports
- Linux Kernel 5.0+

PCIe Card Usage System Requirements

While Echo expansion systems require no drivers beyond those pre-installed in your computer's OS, most PCIe cards you install do; Thunderbolt-compatible drivers to enable them to work properly through the Thunderbolt interface are required. More information on which cards are compatible with the Echo I Desktop is available at: <https://sonnettech.com/support/>

Preparing to Use the Echo Express Chassis With a Mac Computer

The drivers required to support the Echo Express chassis are installed as part of macOS; there are no preparation steps beyond updating your computer to macOS 10.12.6 or newer.

Preparing to Use the Echo Express Chassis With a Windows 10 PC

1. Update Windows if necessary. You must use Windows 10, 64-Bit Version 2004 or newer. To check the version number, type *winver* in the search bar and click enter.
2. For computers with Thunderbolt 3 ports, update your computer's BIOS to the latest version. If you need help updating your BIOS, contact your computer manufacturer.
3. For computers with Thunderbolt 3 ports, update your Thunderbolt Bus Driver to the latest version; you will need version 16.3.61.275 or newer. To check your driver version, go to Settings:Apps:Thunderbolt(TM) Software and you will see the version number. If it is not 16.3.61.275 or newer, then you need to update it. Check with your computer manufacturer for an update.

Preparing to Use the Echo Express Chassis With a Linux Computer

The drivers required to support the Echo Express chassis are installed as part of Linux Kernel 5.0 and later; there are no preparation steps beyond updating your computer to Linux Kernel 5.0 or later.

Chapter 2 – Echo I Desktop Description

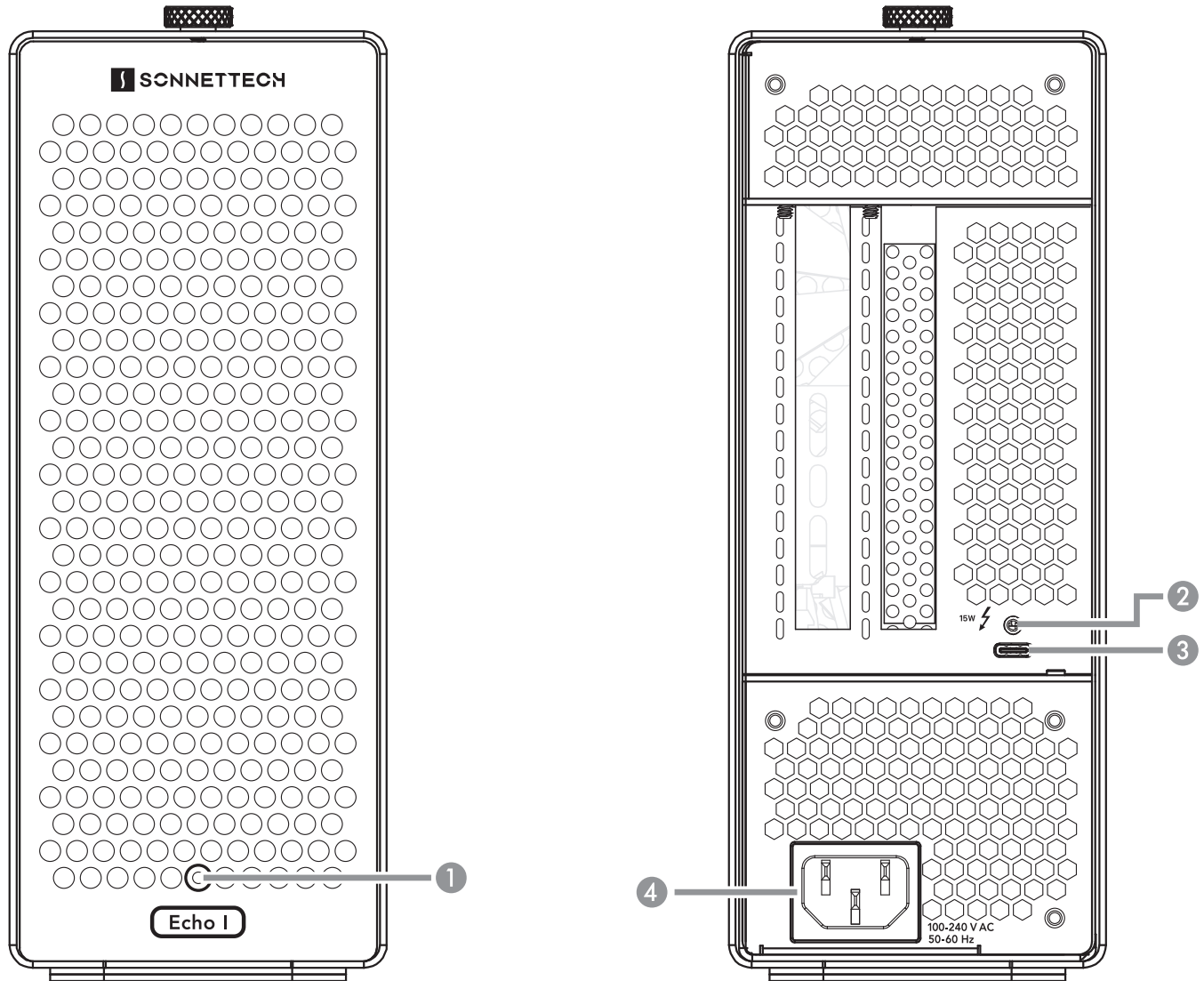

Exterior

1 – Power Indicator LED

This indicator lights when the Echo I Desktop is powered, the Thunderbolt cable between the module and your computer is plugged in securely, and the computer powered on. Note that if the Echo module is connected to another Thunderbolt device instead of directly to the computer, any other Thunderbolt device connected between the computer and Echo chassis must also be powered on before the Echo module's power indicator will light up.

2 – Threaded Nut for ThunderLok 3

Attach the included Thunderbolt connector retainer clip here.

3 – Thunderbolt Port

Connect the included (or comparable) Thunderbolt 3 (40Gbps) cable, or any Thunderbolt 4 cable, between this port and your computer's Thunderbolt port (or other Thunderbolt device in the chain connected to the computer).

4 – Power Input Socket

Connect the included AC power cable here.

Chapter 2 – Echo I Desktop Description

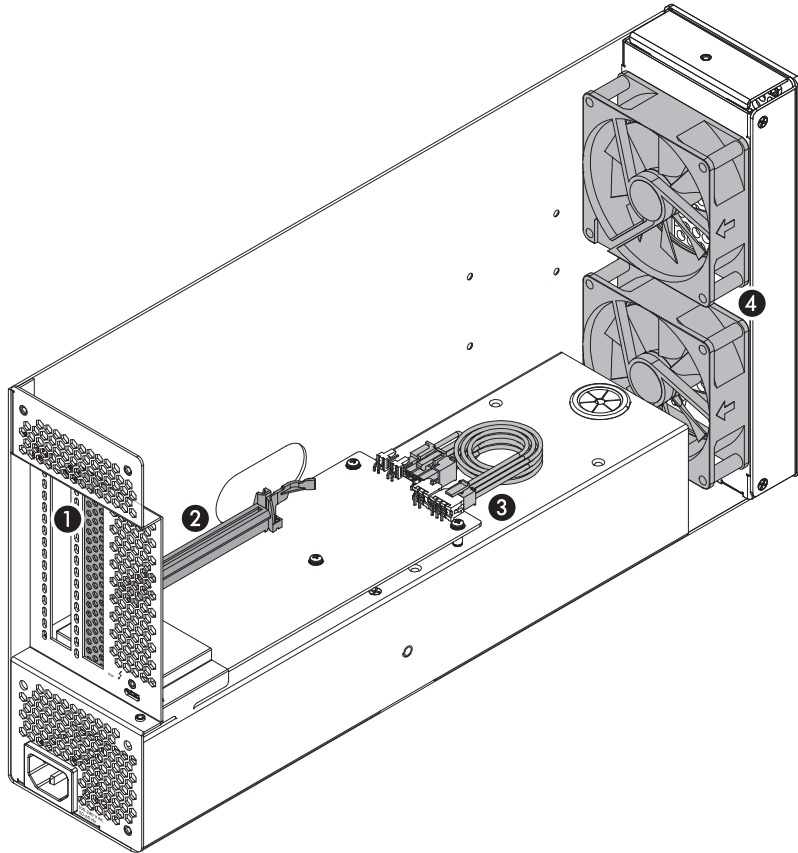

Echo I Module (Inner Assembly)

1 – PCIe Slot Access Cover

Remove this cover when installing a double-width card (or single-width card + daughter card). If only a single-width card is installed, leave this in place.

2 – PCIe Card Slot

This is an x16 mechanical (x4 electrical) PCIe 3.0 slot. It is also compatible with PCIe 4.0, 2.0, and 1.1 cards.

3 – Auxilliary Power Connectors

When auxiliary power is required, these connectors provide power to the installed card.

4 – Temperature-Controlled Fans

These provide cooling for the installed card and the module's supporting Thunderbolt and power circuitry. They operate at a whisper when the cards are running cool, and automatically speed up in steps as the temperature rises. To prevent overheating, do not block the fans or the vent holes on the module.

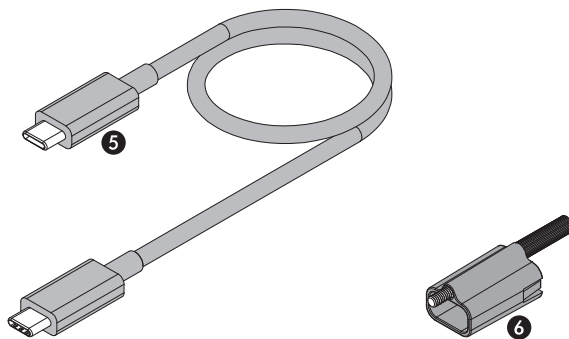

5 – Thunderbolt 3 (40Gbps) Cable

Connect this cable between the Echo module and your computer (or other Thunderbolt device in the chain connected to the computer). Connecting the Echo module to a computer port marked with a generic USB icon (🔌) or USB + Charging Port icon (🔌⚡) is NOT supported.

6– Thunderbolt 3 Connector Retainer Clip

This clip secures the Thunderbolt 3 connector plugged into the Echo module's Thunderbolt port to prevent accidental cable disconnection. This clip is compatible with Sonnet 0.5- and 0.7-meter Thunderbolt 3 cables.

Chapter 3 – PCIe Card Installation and System Setup Steps

1. Remove the Echo I Desktop from its packaging, and then set it on a flat, level surface.
2. Using a Phillips screwdriver, remove and set aside the four screws securing the bottom of the enclosure to the Echo I Module (**Figure 1**).
3. Unscrew and set aside the thumbscrew securing the top of the enclosure to the module (**Figure 1**).
4. Grasping the enclosure with one hand, push the front of the module part way into the enclosure, and then gently pull the module out the back (**Figure 1**). Set aside the enclosure.



Support Note: To avoid damaging components due to static electricity discharge, wear an antistatic wrist strap while working inside the Echo chassis.

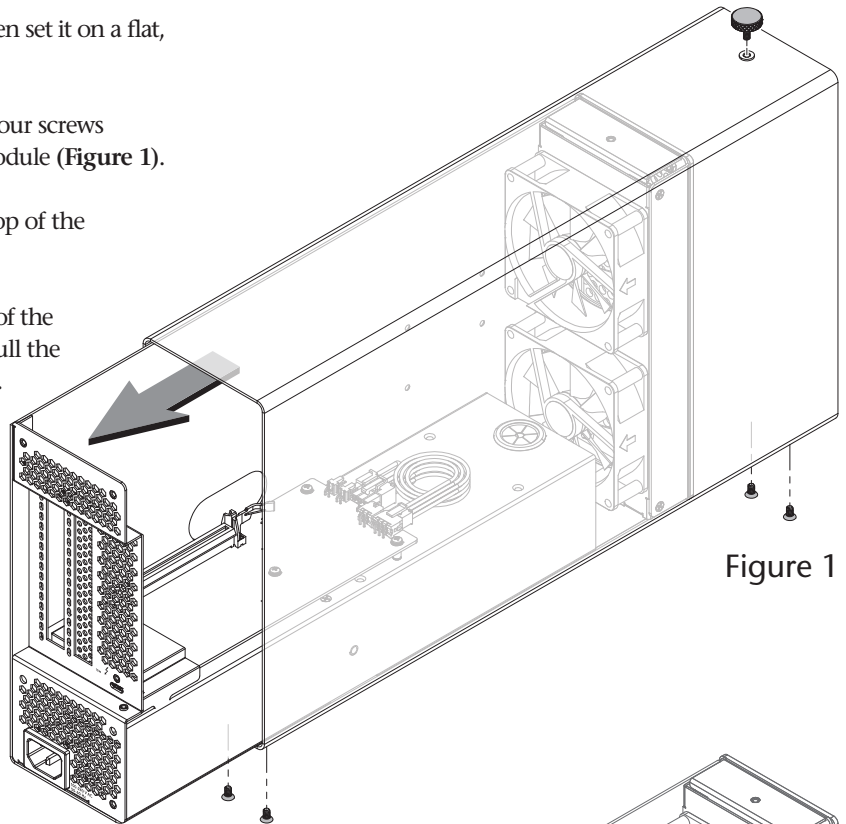

Figure 1



WARNING: When handling computer products, take care to prevent components from being damaged by static electricity; avoid working in carpeted areas. Handle expansion cards only by their edges and avoid touching connector traces and component pins. Also, avoid touching the Echo chassis' circuit boards and any of its components.

5. Remove and set aside the screw used to secure a PCIe card from the module (**Figure 2**). If you are installing a double-width card, or an additional daughter card, remove and set aside the screw securing the PCIe slot access cover, and then remove and set aside the cover.

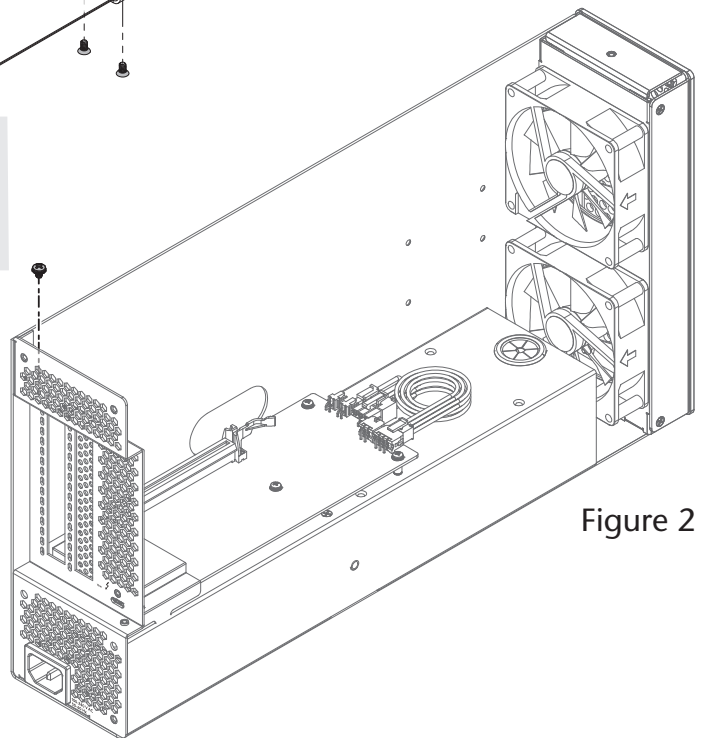

Figure 2

6. **OPTIONAL STEP:** If you are *not* installing a PCIe card which requires auxiliary power, go to step 7. Otherwise, locate the auxiliary power cable (**Figure 3**).

- When installing a Pro Tools | HDX PCIe card, disconnect and set aside the power cable, replace it with the custom power cable included with the Avid card, and then move the loose connectors aside for later connection.
- When installing a card other than the Pro Tools | HDX, remove the cable tie securing the power cable, and then move the loose connector aside for later connection.

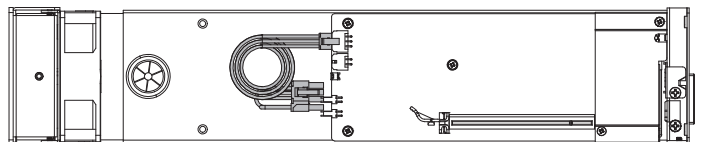

Figure 3

Chapter 3 – PCIe Card Installation and System Setup Steps



Support Note: The Echo I Module includes an “8-pin” auxiliary power connector comprised of a 6-pin plus 2-pin connector pair. To create an 8-pin connector, slide the 6-pin and 2-pin connectors together as shown; note the little nubs on the 2-pin connector that align the connectors to each other (**Figure 4**).

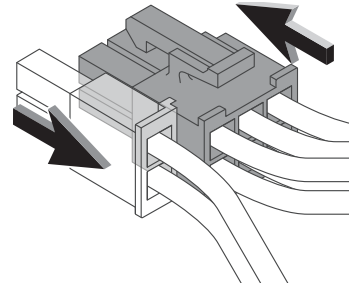

Figure 4

7. Remove the PCIe card from its packaging, handling the card by its edges and without touching any components or gold connector pins.
8. Line up the card's connector with the slot, and then gently but firmly press the card straight into the slot; **do not rock the card or force the card into the slot**. If you encounter excessive resistance, check the card's connector and the slot for damage, and then try inserting the card again (**Figure 5**).
9. If you installed a card which requires auxiliary power, connect the auxiliary power connector to it now.
10. Secure the card using the previously-removed screw or screws (**Figure 5**).

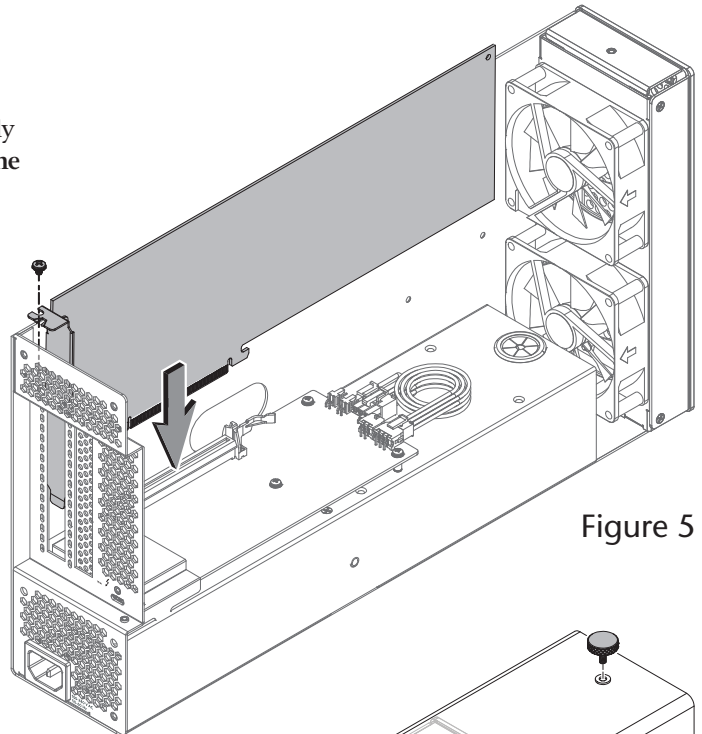

Figure 5

11. Grasping the enclosure, gently push the module back inside from the rear as shown, and then secure the enclosure to the bottom of the module using the four screws you removed previously; **do not overtighten the screws** (**Figure 6**).
12. Using the thumbscrew you removed previously, secure the enclosure to the top of the module; **do not overtighten the screw** (**Figure 6**).

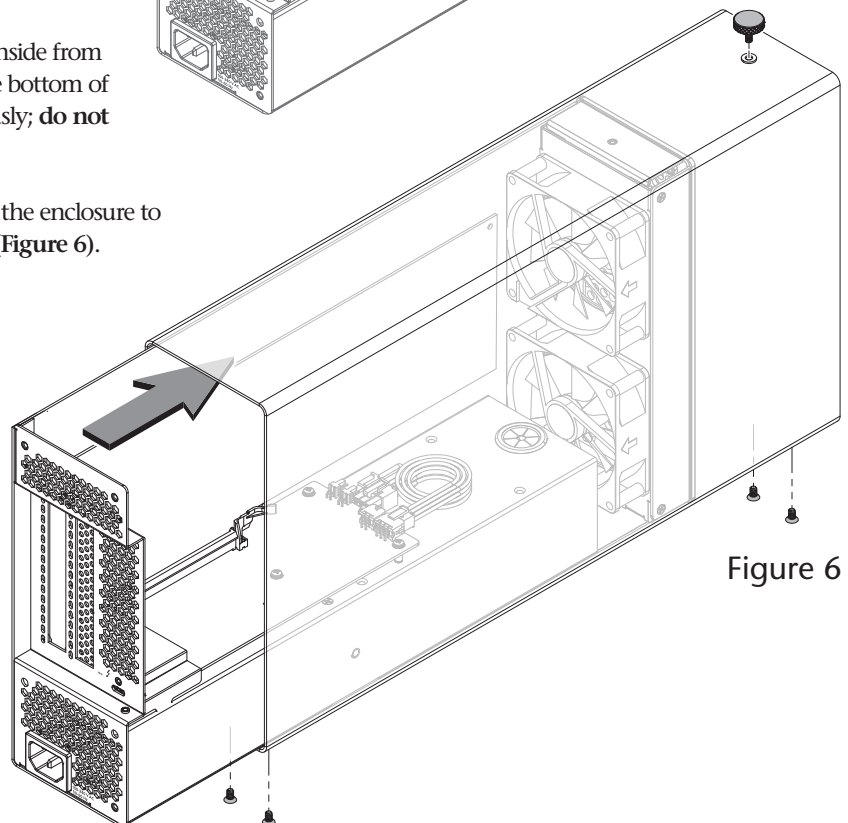



Figure 6

Chapter 3 – PCIe Card Installation and System Setup Steps

 **Support Note:** Sonnet's ThunderLok™ 3 Thunderbolt connector retainer clip secures the included Thunderbolt 3 (40Gbps) cable to the Echo module to prevent accidental disconnects. This clip is compatible with Sonnet 0.5- and 0.7-meter Thunderbolt 3 cables.

To attach the clip to the cable, remove both items from their packaging, and then insert the connector through the connector clip as shown (Figure 7). Note that the connector will pass all the way through the clip; when you connect the cable to the module, the clip will secure the connector.

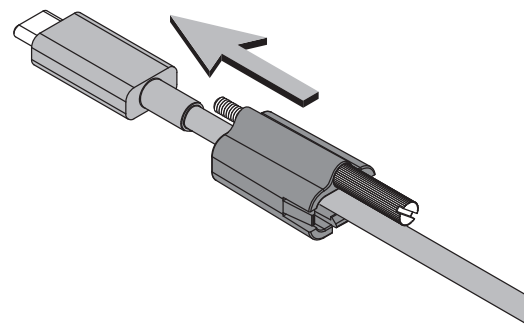

Figure 7

13. Connect the included (or comparable) Thunderbolt 3 (40Gbps) cable, or any Thunderbolt 4 cable, between the Thunderbolt port on the Echo module and a Thunderbolt port on your computer (recommended), or other Thunderbolt device in the chain connected to the computer (Figure 8). Note that cables or computer ports marked with a generic USB icon (🔌) or USB + Charging Port icon (🔌⚡) are NOT compatible. Secure the retainer clip to the module if you attached it.
14. Connect interface cables between devices, PCIe card, and computer as necessary.
15. Connect the included power cord between a wall outlet or power strip and the Echo chassis' power socket. Note that the Echo I Desktop's power indicator will not light until the computer and any other Thunderbolt device connected between it and the Echo module is powered on.

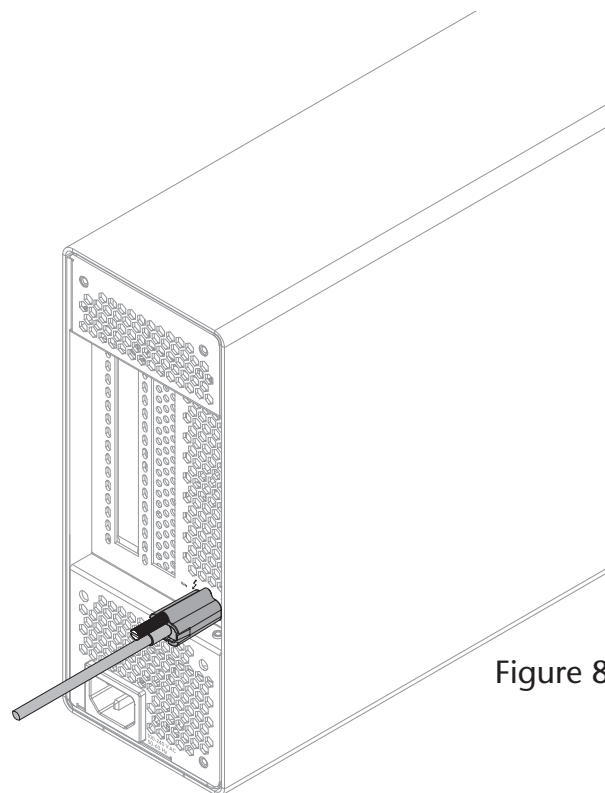

Figure 8

Chapter 4 – Complete Setup and Configuration

SETUP AND CONFIGURATION STEPS—MAC USERS

This page instructs Mac users how to verify the Echo module and installed cards are recognized by the computer; Windows users should skip to the next page.

A – Confirm the Echo I Module is Recognized

1. With the Echo module powered and connected to the computer, turn on the computer. Note that if there are any other Thunderbolt devices connected between the module and your computer, they must also be powered for you to perform the following steps.
2. Press and hold down the Option key, and then from the Apple menu, select System Information; a *System Information* window will open.
3. In the *System Information* window, click Thunderbolt under the Hardware header in the left column (Figure 9).
4. In the top right column under the Thunderbolt Device Tree header, you will see Thunderbolt Bus, and then “DuoModo eGPU Module” (Figure 9).

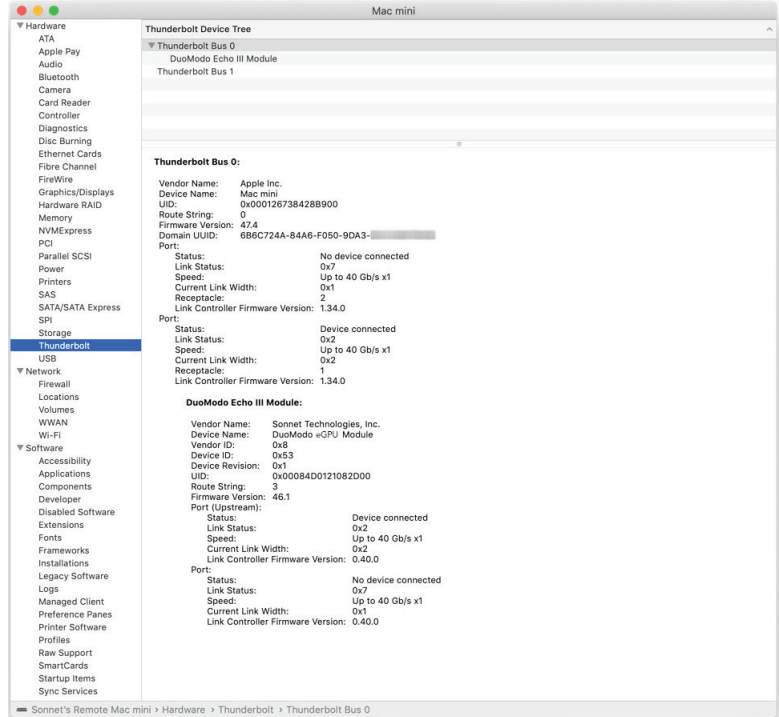

Figure 9



Support Note: If “DuoModo eGPU Module” is not listed, disconnect and reconnect the Thunderbolt cable between the computer and module. Note that it is not necessary to shut down the computer before disconnecting and reconnecting the cable, so long as the installed card is Thunderbolt-compatible.

B – Confirm the Installed Card is Recognized

1. In the *System Information* window click PCI under the Hardware header in the left column (Figure 10).
2. At the top of the right column, the installed card is listed (if not, you may to install drivers before the card is recognized). Click the card; you should see “Yes” next to Driver Installed and Tunnel Compatible, otherwise the card or driver may not be Thunderbolt-compatible (Figure 10).



Support Note: While the Echo module doesn't require drivers beyond those pre-installed in your computer's OS, installed cards require Thunderbolt-compatible drivers to enable their use.

C – Install Card Drivers (If Necessary)

1. Launch a web browser, and then go to your card manufacturer's website. Download and install the latest drivers according to the manufacturer's directions.
2. Restart your computer; your Echo system is ready to use!

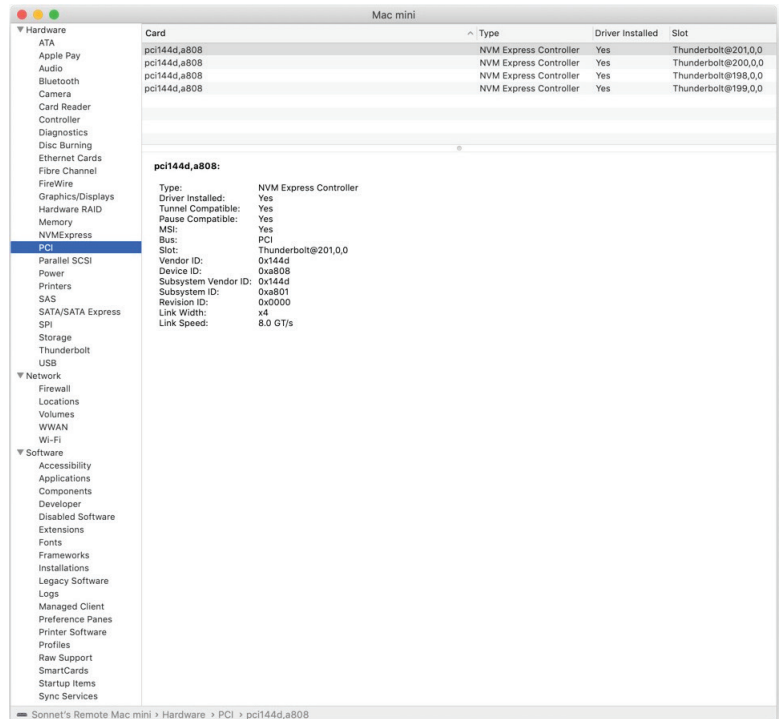

Figure 10

Chapter 4 – Complete Setup and Configuration

SETUP AND CONFIGURATION STEPS—WINDOWS USERS

A – Confirm the Echo I Desktop and Installed Card Is Recognized

1. With the Echo 1 Desktop connected to a power source and to the computer, turn on the computer. Note that if there are any other Thunderbolt devices connected between the Sonnet system and your computer, they must also be powered for you to perform the following steps.
2. When the computer boots for the first time after you connected the Echo system, an *Approve New Thunderbolt™ Devices* window appears. From the drop-down menu select Always Connect, and then click OK.
3. Right-click the Windows Start button, and then select Manage; the *Computer Management* window appears.
4. In the *Computer Management* window, click the category of the card type you installed to expand the listing; a generic adapter listing will appear. After its drivers are installed, the listing will change to display the name of the installed card.

B – Install Card Drivers, If Necessary

1. Launch a web browser, and then go to your card manufacturer's website. Download and install the latest drivers according to the manufacturer's directions.
2. Restart your computer; your Echo system is ready to use!

Chapter 5 – Tips, General Information, and Known Issues

TIPS, GENERAL INFORMATION

Keeping the Card Cool

With its optimized airflow design and temperature-controlled fans providing cooling at all times, the Echo I Desktop provides adequate cooling for the installed card. *Do not operate the Echo module outside its enclosure, and do not block any of the vents!*

Otherwise, the installed card and Echo module's components may overheat.

Hot Plugging the Echo I Module

When a certified Thunderbolt-compatible card (used with Thunderbolt-compatible drivers) is installed, you may connect and disconnect the module while the computer is on. Of course, if you have anything connected to the card, such as storage devices, cameras, etc., follow proper procedures for disconnecting those devices before unplugging the Echo module.

There's No Need to Unplug the Power Cable

Because the Echo I Desktop automatically powers on and off with the computer to which it's connected, there's no power switch, nor is there any need to disconnect the power cable under normal use.

Power Indicator LED Operation

The module automatically powers on and off with the computer to which it's connected, and its power indicator only lights when the computer is on and turns off when the computer is sleeping or powered off.

Using an Expansion Card Without Installing Drivers

Some Thunderbolt-compatible expansion cards, like Sonnet's M.2 4x4 PCIe Card, use inbox (built into the operating system) drivers, and are ready to use out of the box.

Replacing a PCIe Card After Initial Installation

Shut down the computer, and then disconnect the power cable and Thunderbolt cables from the Echo I module before opening the system and replacing the card; **PCIe cards are not hot-pluggable!**

Using the Echo Module to Charge Your Portable Computer

MacBook Air® and MacBook Pro® with Thunderbolt ports, some PC laptop computers with Thunderbolt 3 ports, and all notebooks and laptops with Thunderbolt 4 ports may be charged *slowly* via the Echo module's Thunderbolt port (via 15W Power Delivery). Computers with Thunderbolt 2 or Thunderbolt ports cannot be charged via Thunderbolt.

How to Identify Thunderbolt 3 (40Gbps) Cables

Look for the Thunderbolt icon (⚡) AND the number 3 on the connector housings to identify these cables. Aside from Thunderbolt cables from Apple, USB-C cables with connectors that only have the Thunderbolt icon without the number 3 may only support 20Gbps speeds, and are not recommended for use with the Echo module. Cables marked with a generic USB icon (🔌) are NOT compatible for connecting the Echo module to the computer.

Thunderbolt 4 Cable Compatibility

You may use Thunderbolt 4 cables with Thunderbolt 4 or Thunderbolt 3 computers and peripherals without any compromise in performance or functionality.

KNOWN ISSUES

Not All Thunderbolt 3 Computers' Performance is Equal

While this product features a 40Gbps Thunderbolt 3 interface, some computers equipped with Thunderbolt 3 use an implementation of Thunderbolt 3 that limits PCIe performance to 20Gbps. Mid-2017 and earlier 13-inch MacBook Pro computers with four Thunderbolt 3 ports have this limitation in the two right-hand Thunderbolt 3 ports, while offering full performance from the left-hand ports.

Not All Mac-Compatible Cards Work With M1 Ultra/M1 Max/M1 Pro/M1 Mac Computers

While this product is compatible with M1 series Mac computers, not all PCIe cards that work with Intel-based Macs have M1 series-compatible drivers. We recommend that you contact your PCIe card's manufacturer to verify that the existing drivers support M1 series Macs.

Not all PCIe Cards Will Perform at 100%

Thunderbolt 3's PCIe bandwidth is limited to 2,750 MB/s when used with a Thunderbolt 3 host, and 3,000 MB/s when used with a Thunderbolt 4 host. While most cards will operate at full performance, some may not because they require more bandwidth than Thunderbolt 3 can provide.

Not All Thunderbolt Cables Deliver Full Performance

Full performance from the Echo system requires the use of the included (or comparable) Thunderbolt 3 (40Gbps) cable, or any Thunderbolt 4 cable. When shopping for a Thunderbolt 3 cable, please be aware that some support only lower data transfer speeds (20Gbps).

Operating System (OS) Updates May Break Compatibility

Specific device drivers that work under one OS version may not work under a later version. Before updating your computer to the latest OS, we recommend that you contact your PCIe card's manufacturer to verify that the existing drivers work. Note that other computer software updates may also break compatibility.

Chapter 6 – Precautions, FCC Compliance, and Support Information

SAFETY PRECAUTIONS

Please read this section carefully before proceeding. These precautions explain the correct and safe use of this device, thereby helping to prevent injury to you or others, and also help you to minimize the risk of damaging the device.

Warnings

Always follow the basic warnings listed here to avoid the risk of serious injury or death from electrical shock, short-circuiting, fire, and other hazards. These warnings include, but are not limited to:

- Do not attempt to modify the enclosure. If this device appears to be malfunctioning, contact your reseller or local distributor.
- Do not drop the chassis; dropping or mishandling chassis may result in a malfunction leaving the product inoperable.
- Do not insert foreign objects inside the slot(s).
- Do not expose the device to rain, use it near water or containers that contain liquids which might spill into any openings, or in damp or wet conditions.
- If unusual smells, sounds, or smoke come from the device, or if liquids enter it, unplug it from the electrical outlet immediately.
- Follow the instructions in this manual carefully; contact your reseller or local distributor for additional advice not covered in this User's Guide.

FCC Compliance

Echo I Desktop complies with Part 15 of the FCC Rules. Operation is subject to the following two conditions: This device may not cause harmful interference, AND this device must accept any interference received, including interference that may cause undesired operation.

Contacting Customer Service

The Sonnet Web site located at www.sonnettech.com has the most current support information and technical updates. Before contacting Customer Service, please check our Web site for the latest updates and online support files, and check this User's Guide for helpful information.

Email support requests generally receive the fastest responses, and are usually processed within a 24-hour period during normal business hours, excluding holidays. When you contact Customer Service, have the following information available so the customer service staff can better assist you:

- Product name
- Computer model
- PCIe card model
- Operating system version you're using
- Software/firmware versions
- A System Report (macOS) or a Microsoft System Information MSINFO32 (Windows) report (Windows), along with a description of the issue(s) you are encountering with your device

If further assistance is needed, please contact **Sonnet Customer Service** at:

E-mail: support@sonnettech.com

Tel: 1-949-472-2772

(Monday–Friday, 9 a.m.–5 p.m. Pacific Time, excluding holidays)

Japan Customers

Contact Sonnet Customer Service Japan at:

E-mail: jp.support@sonnettech.com