

AirMedia® Series 3 Receiver 100 with Wi-Fi® Network Connectivity

The AirMedia® Series 3 Receiver 100 (AM-3100-WF and AM-3100-WF-I) enables secure wireless collaboration in the modern digital workspace. Easy to deploy and manage, install the Receiver in conference rooms, huddle rooms, lounges, lobbies, or almost any space to establish a productive meeting environment.



Install the Device

The device can be placed or mounted onto a flat surface.

Place onto a Flat Surface

Place the device onto any flat, level surface. The rubber strips on the bottom of the device prevent it from moving easily.

Mount onto a Flat Surface

Using the included mounting screws and anchors, mount the device onto a flat surface such as a wall or the underside of a table. Use the mounting template on the following page to determine the mounting hole locations.

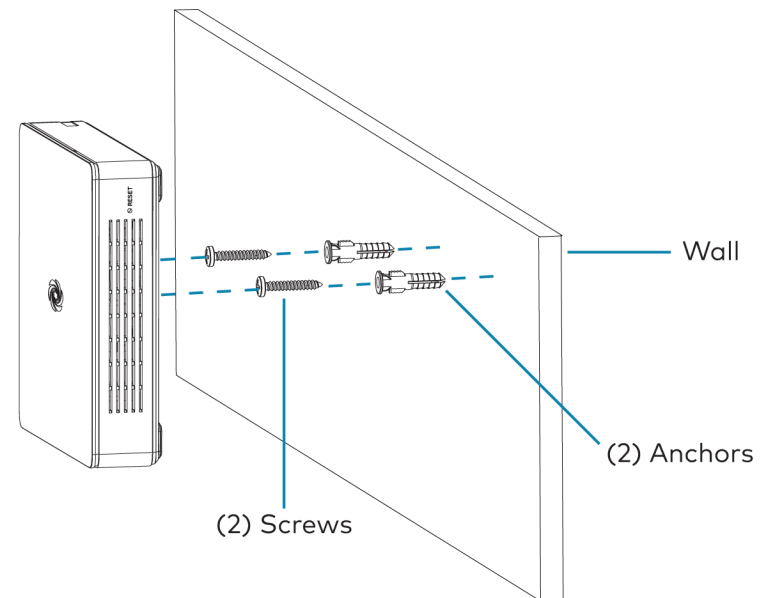

In the Box

- 1 AirMedia Series 3 Receiver (AM-3100-WF, 6511540 or AM-3100-WF-I, 6511541)

Additional Items

- 2 Anchor, Wall, Plastic (2057414)
- 2 Screw, Metal, 1.18 in. (30 mm) (2057420)

AirMedia® Series 3 Receiver 100 with Wi-Fi® Network Connectivity

AM-3100-WF and AM-3100-WF-I Mounting Template

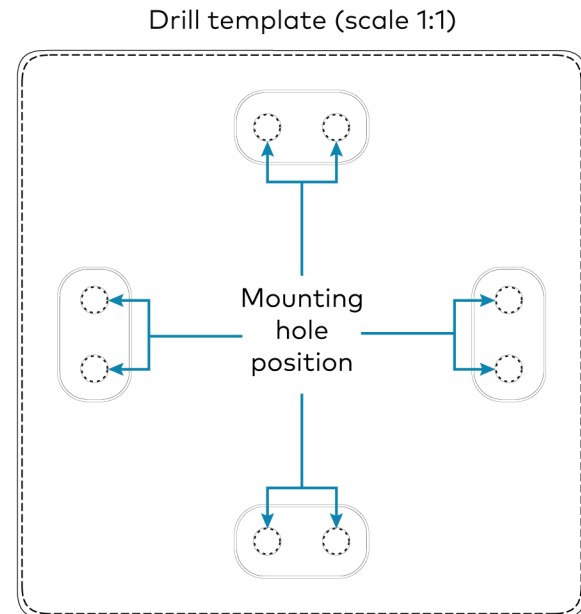
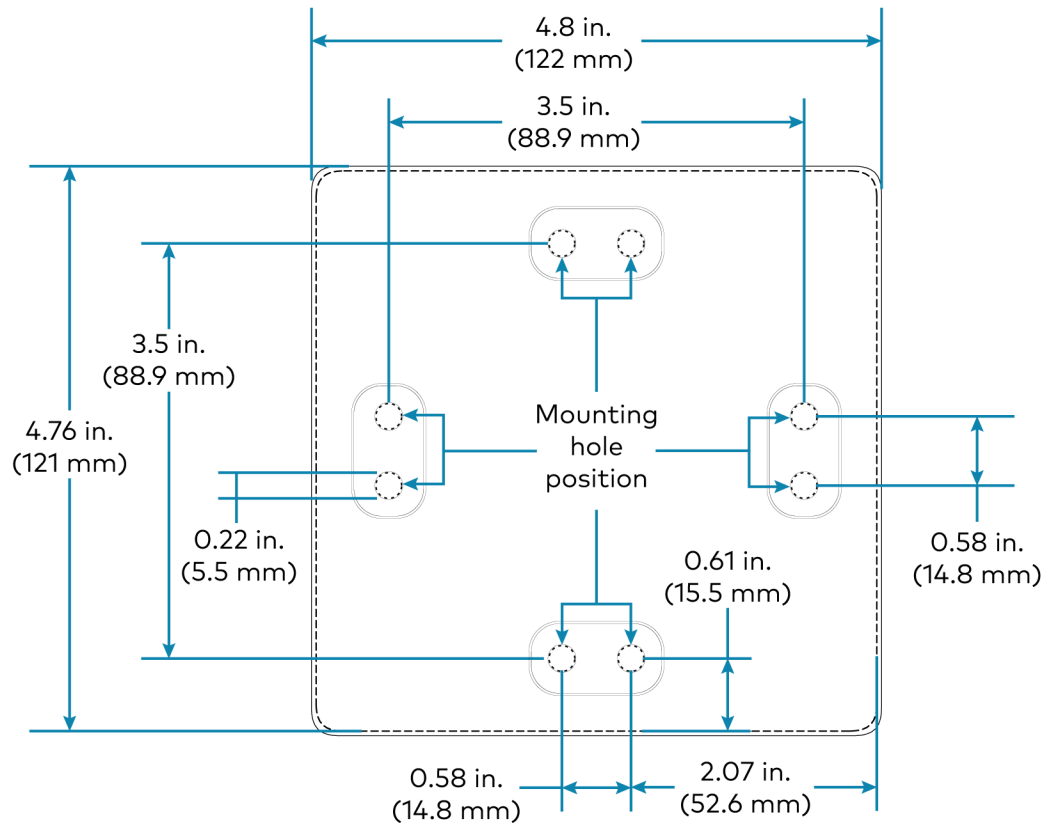

AirMedia® Series 3 Receiver 100 with Wi-Fi® Network Connectivity



Make Connections

Make connections to the device as shown in the following diagram.

Rear Panel Connections

NOTES:

- The device receives power from a Power over Ethernet (PoE+, IEEE 802.3at) connection. It can also receive power from the [PW-2412WU](#) power pack (sold separately).
- PoE-type networks connected to the LAN PoE+ port are for intrabuilding use only. Do not connect this device to lines that run outside of the building.

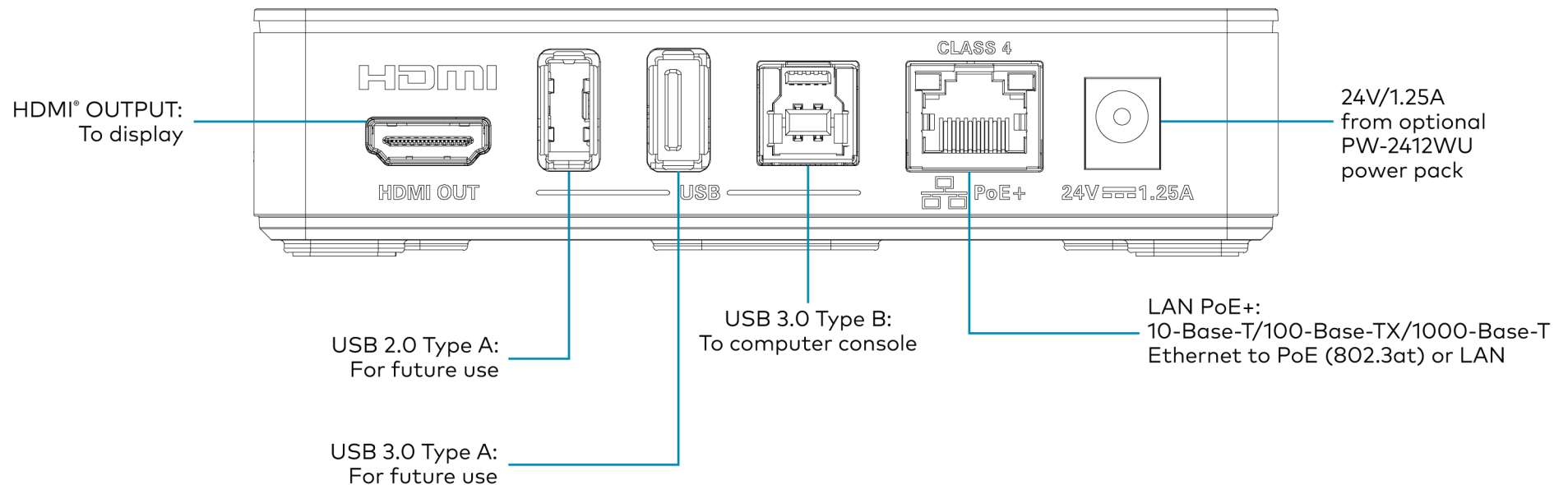

AirMedia® Series 3 Receiver 100 with Wi-Fi® Network Connectivity



Configure the Device

Configure the device using the web interface. To access the web interface, open a web browser and then go to the IP address of the device. For more details on device configuration, refer to the [AirMedia Series 3 Receivers Product Manual](#) (Doc 9020).



Observe the LED Indicators

Refer to the following table and diagram for information about the LED indicators on the device.

LED Indicator	Color	Meaning
Power	White	Power is being applied to the device. The device is operational.
	Amber	Power is being applied to the device. The device is booting.
Setup	White	The setup button was pressed.
Online	White	The device is connected to a Crestron Control System.
HDMI	White	A video signal is being transmitted to the HDMI output.
LAN Indicators (located on rear panel)	Green	An Ethernet link is established.
	Flashing amber	Data activity is occurring on the Ethernet link.

LED Indicators - Front Panel

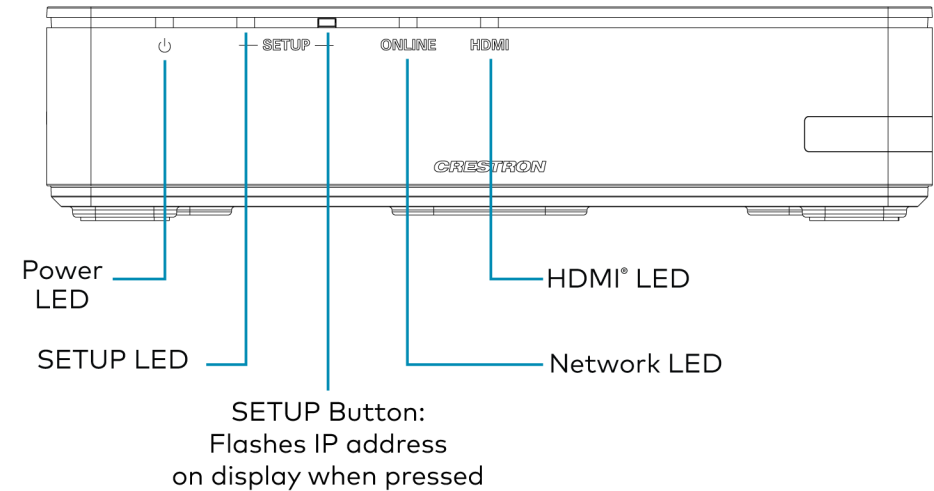

Visit the Product Page

Scan the QR code to visit the product page.

AM-3100-WF



www.crestron.com/model/6511540

AM-3100-WF-I



www.crestron.com/model/6511541

AirMedia® Series 3 Receiver 100 with Wi-Fi® Network Connectivity



Important Safety Instructions

Important Safety Instructions

WARNING: When using this product, basic precautions should always be followed, including the following:

1. Read these instructions carefully.
2. All cautions and warnings should be followed.
3. The equipment should only be used at maximum 40°C (104°F) ambient temperature.
4. Opening the equipment could result in electrical shock and should only be done by qualified service personnel.
5. Protect equipment from humidity.
6. Do not insert foreign objects or liquids into the openings, this could cause a fire or electrical shock.
7. Do not use chemical detergents to clean the device, use a soft dry cloth.
8. To avoid damage from electrical peaks unplug the device when it is not in use.
9. If one of the following situations arise, equipment has to be checked by qualified service personnel:
 - Liquid has penetrated into the equipment.
 - Equipment has been exposed to humidity.
 - Equipment has been dropped and/or is damaged.
 - Equipment has obvious sign of breakage.
 - Equipment does not work well or you can not get it working according to user's manual.
10. Do not expose the equipment to water or place object filled with water on top of it.



Instructions importantes

Instructions de sécurité importantes

Les avertissements: concernant l'utilisation de ce produit doivent toujours être fondés sur les précautions fondamentales, notamment:

1. Lisez attentivement ces notes.
2. Tous les avertissements et avvertissements doivent être respectés.
3. L'équipement ne peut être utilisé qu'à une température ambiante maximale de 40°C (104°F).
4. L'ouverture de l'appareil peut provoquer un choc électrique qui ne peut être assuré que par un personnel d'entretien qualifié.
5. Empêcher l'humidité du dispositif.
6. Il est interdit d'introduire des objets étrangers ou liquides dans l'ouverture, faute de quoi cela pourrait provoquer un incendie ou un choc électrique.
7. Ne pas utiliser d'appareil de nettoyage chimique et utiliser un tissu sec souple.
8. Pour éviter les dommages de crête électrique, retirez la fiche d'alimentation lorsque le dispositif n'est pas utilisé.
9. Dans l'un des cas énoncés ci-dessous, le matériel doit être vérifié par un service qualifié:
 - Dispositif d'infiltration de liquide.
 - L'équipement est exposé à l'humidité.
 - Matériel tombé et/ou endommagé.
 - L'équipement a été endommagé.
 - Le matériel ne fonctionne pas correctement ou ne peut pas être utilisé conformément au Manuel de l'utilisateur.
10. L'équipement ne doit pas être exposé à l'eau ni être placé sur des objets remplis d'eau.

AirMedia® Series 3 Receiver 100 with Wi-Fi® Network Connectivity

Additional Information

Original Instructions

The U.S. English version of this document is the original instructions. All other languages are a translation of the original instructions.

Regulatory Model: M202018001

Crestron product development software is licensed to Crestron dealers and Crestron Service Providers (CSPs) under a limited nonexclusive, nontransferable Software Development Tools License Agreement. Crestron product operating system software is licensed to Crestron dealers, CSPs, and end-users under a separate End-User License Agreement. Both of these Agreements can be found on the Crestron website at www.crestron.com/legal/software_license_agreement.

The product warranty can be found at www.crestron.com/warranty.

The specific patents that cover Crestron products are listed at www.crestron.com/legal/patents.

Certain Crestron products contain open source software. For specific information, visit www.crestron.com/opensource.

Crestron, the Crestron logo, and AirMedia are either trademarks or registered trademarks of Crestron Electronics, Inc. in the United States and/or other countries. HDMI is either a trademark or registered trademark of HDMI Licensing LLC in the United States and/or other countries. Wi-Fi is either a trademark or registered trademark of Wi-Fi Alliance in the United States and/or other countries. Other trademarks, registered trademarks, and trade names may be used in this document to refer to either the entities claiming the marks and names or their products. Crestron disclaims any proprietary interest in the marks and names of others. Crestron is not responsible for errors in typography or photography.

©2021 Crestron Electronics, Inc.

Doc. 8982A

08/02/21