



Suspension Bracket
for Wood Beams

SUSPENSION CLAMP

The BC-W7-12-9 provides a safe and secure overhead rigging point from underneath regular structural wood and Glulam overhead beams. This rugged, all-steel three-piece design will accommodate beam depths of 9" (230 mm) or more and widths from 7 inches wide to 12 inches wide (180-300 mm).

Its hang point eye is secured to a loading channel which is oriented underneath and in the center of the wood beam and swivels in the direction of the pull to minimize the side loading when a load is not vertical and splayed out from center.

Two side plates anchor into the wood beam via lag bolts or through bolts, depending upon the application. If not certain, check with a structural engineer for the best method of attachment.

The two side plates support the load channel below, which slides through both side plates and lock in permanently via two angle tabs. The beam clamp components are powder coated in a choice of two colors, semi-gloss black and off-white.

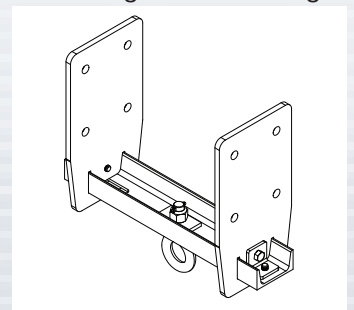

3 Piece Adapter

KEY FEATURES:

- ▶ Load-rated suspension point
- ▶ Swiveling hang point
- ▶ Powder Coat finish
- ▶ Easy permanent installation

OPTIONAL ACCESSORIES:

- ▶ See Rigging Components Datasheet

* Not for human suspension

*Review installations with a structural or building engineer if needed for the best method of attachment and to determine safe splay angles.

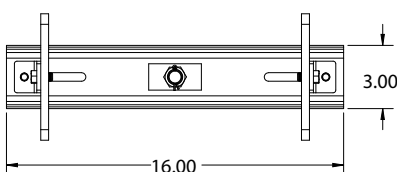

SPECIFICATIONS:

Material: Structural steel
Weight: 21 lb/ 9.5 Kg
Finish: Powder coat
Color: Black
WLL: 980 lb at 0 degrees
WLL: 380 lb at 45 degrees
Design factor: 5:1

PACKAGE CONTENTS:

2 pcs Side plates
1 pc. Load channel with swivel eye
2 pcs locking angle and fasteners



Rated for indoor use.

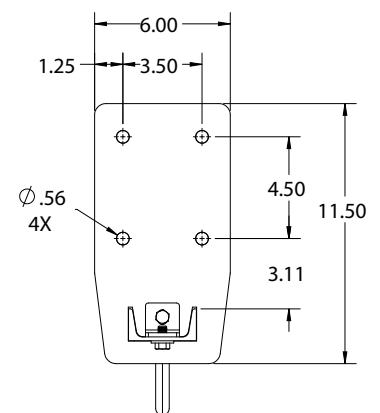
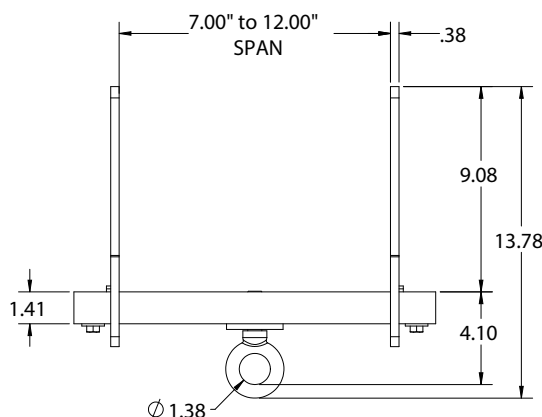

ALWAYS INSTALL SAFETY CABLES

WARNING: Mounting and/or suspension of equipment requires experienced professionals. Improperly installed equipment can result in property damage, personal injury and/or liability to the installing contractor.