

# RAD360 WIRELESS MICROPHONE SYSTEM

## OVERVIEW:

The Audix RAD-360 is a frequency agile UHF wireless microphone system with 193 selectable frequencies (per system group) and dual tuner, true diversity receivers. Operating in the UHF band between 614–662 MHz, The RAD-360 is designed for a wide range of professional applications including live performances, regional sound companies, fixed installations, corporate meetings and events and houses of worship.

The RAD-360 features easy-to-use and easy-to-read menu driven displays in every component of the system. Both the receiver and the transmitter are synthesizer controlled via Phase Locked Loop (PLL) for stable Radio Frequency (RF) signals.

The RAD-360 handheld transmitters are constructed with durable metal housings and feature legendary performance of the OM-series dynamic microphones from Audix—microphones that have set standards in the pro audio industry for clarity, feedback rejection and dependability. The hand-held transmitters have a convenient gain setting control that will enable a -6, -12 or -24 dB pad to help prevent overload or distortion.

The modular design of the threaded capsule housing assembly means that the user can easily change the transmitter mic capsule from one OM Series model to another in a matter of seconds.

The body pack transmitter, constructed of durable ABS composite, is housed in a protective metal cradle. It may be used with lavalier, headset and specialty instrument microphones. A guitar system is also available. Mic/line input adjustments are provided as well as sensitivity/gain control.

The receiver is rack-mountable for either 1 or 2 systems into a standard 19 inch rack with optional rack mount kits. An optional amplified Antenna Distribution System (ADS-4) is available, allowing up to 4 systems to be run off a single pair of antennas and one DC power supply. An optional antenna booster (AB-1), which can be wall-mounted or mic stand mounted, is available to strengthen incoming signals, improve signal to noise ratio and increase the RF range.

NOTICE: Users of wireless microphones in the USA, on frequencies listed under FCC part 74.801 must comply with eligibility & licensing requirements under FCC Part 74.832. Please review terms at:

[www.access.gpo.gov/nara/cfr/waisidx\\_00/47cfr74\\_00.html](http://www.access.gpo.gov/nara/cfr/waisidx_00/47cfr74_00.html)

Receipt or use of this product acknowledges acceptance of the FCC regulations.

For further questions, you may contact Audix.

## FEATURES:

- Frequency Agile
- Soft-key Controls
- Backlit LCD Menu Driven Displays
- Noise Squelch Circuitry Analyzes signal quality
- Surface Acoustic Wave (S.A.W.) Filters RF resistance
- Tone Key Squelch Eliminates unwanted noise
- Tuned Antennas
- Audio Output
- RF Level Meters
- Audio Meters
- Battery Power Indicators
- Easy to use Set and Lock Function
- Sensitivity Adjustment
- Interchangeable Head Assemblies
- Durable Metal Housings



## SUPPLIED ACCESSORIES:

- DC Power supply - 110 VAC, 12V-350 milliamp (PS-110R)
- Two 3/4 Wave UHF whip antennas (ANT-1)
- Rack mount kit for 1 -RAD360R (RM1)
- Zippered carrying case (CASE-360A)
- Microphone clip for handheld transmitter (MC-360T)

## OPTIONAL ACCESSORIES:

- RM2 - Rack mount kit for 2 -RAD360R
- CBL-RM1 - 3' antenna extension cable with BNC connectors
- ADS-4 - Antenna Distribution System (for up to 4 systems)
- AB1 - UHF antenna booster
- ANT-D360 - Active UHF directional antenna paddle
- CBL-G360 - 3' Guitar cable for bodypack

## SYSTEM COMPONENTS:

- R360 UHF true diversity receiver
- B360 UHF bodypack
- T360 - UHF hand held transmitter (without capsule assembly)
- T363 - UHF Handheld transmitter with OM3 capsule
- T365 - UHF Handheld transmitter with OM5 capsule
- T366 - UHF Handheld transmitter with OM6 capsule
- T367 - UHF Handheld transmitter with OM7 capsule
- T363-CA - OM3 Capsule assembly for handheld transmitter
- T365-CA - OM5 Capsule assembly for handheld transmitter
- T366-CA - OM6 Capsule assembly for handheld transmitter
- T367-CA - OM7 Capsule assembly for handheld transmitter

## LAVALIER & SPECIALTY MICROPHONES for BODYPACK:

- ADX5 - Black omni lavalier with 3' cable
- ADX10 - ADX10 cardioid lavalier with 3' cable
- HT2 - Headset mic with 3' cable
- HT5 - Slim line omni headset microphone-black
- HT5-BG - Slim line omni headset microphone-beige
- ADX20i - ADX20i Instrument mic with 3' cable

# RAD360

**SPECIFICATIONS:**

Frequency Range	614 MHz-662 MHz
Switchable Frequencies	193 (per system group of 24 MHz spaced 125 kHz apart)
Freq Response	40 Hz-18 kHz (depending on capsule)
Signal To Noise Ratio	>110 dB
Companer System	HDX
Pilot Tone	32.768 kHz
<i>R360 Receiver</i>	
Receiving System	Dual tuners, true diversity receiver
Image Rejection	50 dB nominal, 45 dB minimum
Signal-to-noise Ratio	110 dB @ 30 kHz deviation (IEC-weighted), max modulation 75 kHz
Total Harmonic Distortion	1% (10 kHz deviation at 1 kHz)
Sensitivity	26 dBµV (S/N 60 dB at 5 kHz deviation, IEC-weighted) <2.5µV
Intermediate Frequency	55.875 MHz, 10.7 MHz
Audio Output	Unbalanced: 40 mV (at 1 kHz, 10kHz deviation, 10k ohm load)
(AF Level set at "0")	Balanced: 8mV (at 1 kHz, 10kHz deviation, 600 ohm load)
Output Connectors	Unbalanced: 1/4" phone jack
	Balanced: XLR
Nominal Peak Deviation	Balanced: -24 to +18dBu
	Unbalanced: -30 to +12dBu (adjustable in 6 dB-steps)
Adjacent Channel Rejection	>68 dB
Intermodulation Spacing	>68 dB
Image Rejection	>72 dB
Power Supply	120V AC 60 Hz; 12-18V DC, 350 mA, with external supply
Dimensions	8.35" (W) x 1.1" (H) x 6.5" (D)
	212mm (W) x 38mm (H) x 165 mm (D)
Net Weight	2.32 lbs / 1050 g
<i>T360 Handheld Microphone Transmitter</i>	
RF Power Output	50 mW Max
Spurious Emissions	< -54 dBm
Battery (not included)	2- AA 1.5 V
Current Consumption	100 mA typical
Battery Life	Approximately 12 hours (depending on battery type and usage)
Max Sound Pressure Level	>140 dB (depending on capsule)
Dimensions	1.3" diameter body, 2.1" diameter grill x 9.4" (L)
	33 mm diameter body, 53.4 mm diameter grill x 238.67 mm (L)
Net Weight	(without battery) 12.35 oz / 350 g
<i>B360 Bodypack Transmitter</i>	
RF Power Output	50 mW Max
Spurious Emissions	Under federal regulations
Input Connector	3 pin mini-XLR
Input Controls	Mic/line switch, and 20 dB potentiometer
Battery	(not included) 2- AA 1.5 V
Current Consumption	100 mA typical
Battery Life	Approximately 12 hours
Input Impedance	Mic: 10kOhm Line: 1M Ohm
Max Sound Pressure Level	approx. 128-140 dB (depending on mic)
Dimensions	71.3 mm (W) x 104 mm (L) x 27 mm (D)
	2.8 inches (W) x 4 inches (L) x 1 inch (D)
Net Weight	(with battery) 7.2 oz / 204.5 g

**DIMENSIONS (mm):**

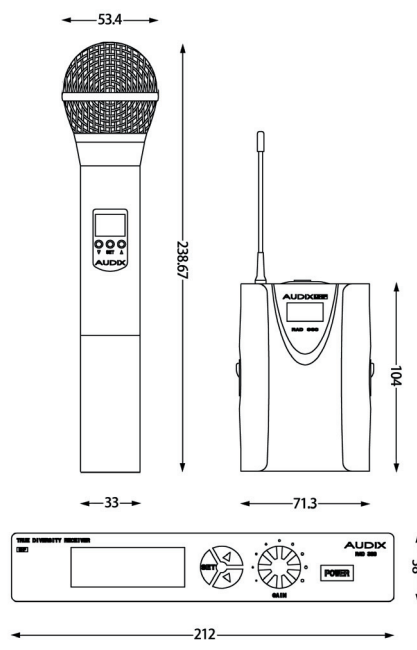

\*\*\*All specifications subject to change without notice.

**SERVICE AND WARRANTY:**  
This microphone is under warranty for a period of 3 years from any and all manufacturing defects. Should your microphone fail in any way, please contact the Audix Service department at 503-682-6933. A Return Authorization number is required before returning any products.

**CARE AND MAINTENANCE:**  
The RAD360 is manufactured to exacting specs with roadworthy construction. However, the capsule is highly sensitive and should be handled with care. Avoid extreme temperatures and be sure to store your microphone in the pouch provided when not in use. Moisture of any kind can adversely affect the sound and performance of your microphone.



www.audixusa.com  
503-682-6933 Fax: 503-682-7114  
Audix Corporation 9400 SW Barber St. Wilsonville, OR 97070



**AUDIX WARRANTY REGISTRATION FORM**

Name: \_\_\_\_\_ Model: \_\_\_\_\_  
 Company: \_\_\_\_\_ Serial Number: \_\_\_\_\_  
 Address: \_\_\_\_\_ Store: \_\_\_\_\_  
 City: \_\_\_\_\_ Store Location: \_\_\_\_\_  
 Prov./State: \_\_\_\_\_ Zip: \_\_\_\_\_ Purchase Date: \_\_\_\_\_  
 Phone: ( ) \_\_\_\_\_ Signature: \_\_\_\_\_  
 Email: \_\_\_\_\_ Date: \_\_\_\_\_

Please Check all that apply:

Male  Female

Age:  
 18 or Under  
 19-25  
 26-35  
 36-45  
 46-55  
 55 +

Occupation:  
 Musician  
 Producer  
 Sound Eng.  
 Radio/TV  
 Production  
 Other \_\_\_\_\_

Primary Instruments:  
 Vocal  
 Guitar / Bass  
 Drums  
 Keyboard  
 Brass  
 Woodwinds  
 Strings  
 Other \_\_\_\_\_

Product to be used for:  
 Pro live sound  
 Pro recording  
 Home recording  
 Rehearsal  
 Installation  
 School  
 House of Worship  
 Other \_\_\_\_\_

How did you hear about Audix?  
 Magazine Ad  Online Ad  
 On-line Store  Friend  
 Salesman  Other \_\_\_\_\_

Do you own other Audix Products?  Yes  No  
 Model(s) \_\_\_\_\_  
 Have you visited the Audix website?  Yes  No

Please register your product online at [www.audixusa.com](http://www.audixusa.com) or mail this form to:  
 Audix Microphones P.O. Box 4010 Wilsonville, OR 97070