

5051

Inductor EQ / Compressor

By:



Serial #:



Operations Manual

5051 Inductor EQ / Compressor

Thank you for your purchase of the 5051 Inductor EQ / Compressor. Everyone at Rupert Neve Designs hopes you enjoy using this tool as much as we have enjoyed designing and building it. Please take note of the following list of safety concerns and power requirements before the use of this product.

Safety

It's usual to provide a list of "do's and don'ts" under this heading but mostly these amount to common sense issues. However here are some reminders:

Don't operate your 5051 module in or around water! Electronic equipment and liquids are not good friends. If any liquid is spilled such as soda, coffee, alcoholic or other drink, the sugars and acids will have a very detrimental effect. Sugar crystals act like little rectifiers and can produce noise (crackles, etc.). SWITCH OFF IMMEDIATELY because once current starts to flow, the mixture hardens, can get very hot (burnt toffee!) and cause permanent and costly damage. Please contact support as soon as possible at support@rupertneve.com for resolution.

Safety Instructions: 1) Read these instructions.

2) Keep these instructions.

3) Heed all warnings.

4) Follow all instructions.

5) Do not use this apparatus near water.

6) Clean only with dry cloth.

7) Do not block any ventilation openings. Install in accordance with the manufacturer's instructions.

8) Do not install near any heat source such as radiators, heat registers, stoves, or other apparatus (including amplifiers) that produce heat.

9) Do not defeat the safety purpose of the polarized or grounding-type plug. A polarized plug has two blades with one wider than the other. A grounding type plug has two blades and a third grounding prong. The wide blade or the third prong are provided for your safety. If the provided plug does not fit into your outlet, consult an electrician for replacement of the obsolete outlet.

10) Protect the power cord from being walked on or pinched, particularly at plugs convenience receptacles and the point where they exit from the apparatus.

11) Only use attachments/accessories specified by the manufacturer.

12) Unplug this apparatus during lightning storms or when unused for long periods of time.

13) Refer all servicing to qualified service personnel. Servicing is required when the apparatus has been damaged in any way, such as when power-supply cord or plug is damaged, liquid has been spilled or objects have fallen into the apparatus, the apparatus has been exposed to rain or moisture, does not operate normally, or has been dropped.

14) Do not expose this apparatus to rain or moisture.

15) The apparatus shall be connected to a mains socket outlet with a protective earthing connection.

Power Requirements

Each Portico 5051 is fitted for use with a specialized stand alone, 5051 power supply module. The power supply features a proprietary 4 pin polarized input for +24 and -24V DC power input, and will power up to 25 5051 modules

5051: Front Panel

High Frequency Shelf / Peak
 Selectable at 8 and 16 KHz. With continuous gain from -15 to +15dB. Selectable peak or shelf curves

Mid Parametric
 Selectable at 200, 350, 700, 1.5 K, 3 K, and 6 KHz. With continuous gain from -15 to +15dB. Selectable Hi Q.

Low Frequency EQ
 Selectable at 35, 60, 100, and 220 Hz. Continuous gain from -15 to +15dB Selectable peak or shelf curves.

Make-Up Gain
 Applies post-compressor make-up gain

SC HPF
 Applies a HPF at 250 Hz to the VCA side chain signal

Attack Time
 Changes the time delay before compression begins

FF/FB
 When engaged, changes the VCA detection from feed-forward to feed-back

Threshold
 Sets the level at which compression begins

Line Select
 Selects between line 1 and line 2

EQ Pre / Post
 When engaged, moves the EQ after the compressor

HPF
 Cycles between bypassed, HPF at 60 HZ, and HPF at 120Hz

Level & Gain Reduction Meters
 8 segment LED Meter for monitoring gain reduction and output level

Release Time
 Changes the time taken for the gain return to 0 after the compressor disengages

Link
 Links the 5051 VCA to the 5051 module to which it is connected

Ratio
 Changes the amount of gain reduction above the set threshold level

Comp IN
 Engages the Compressor

5051: Back Panel

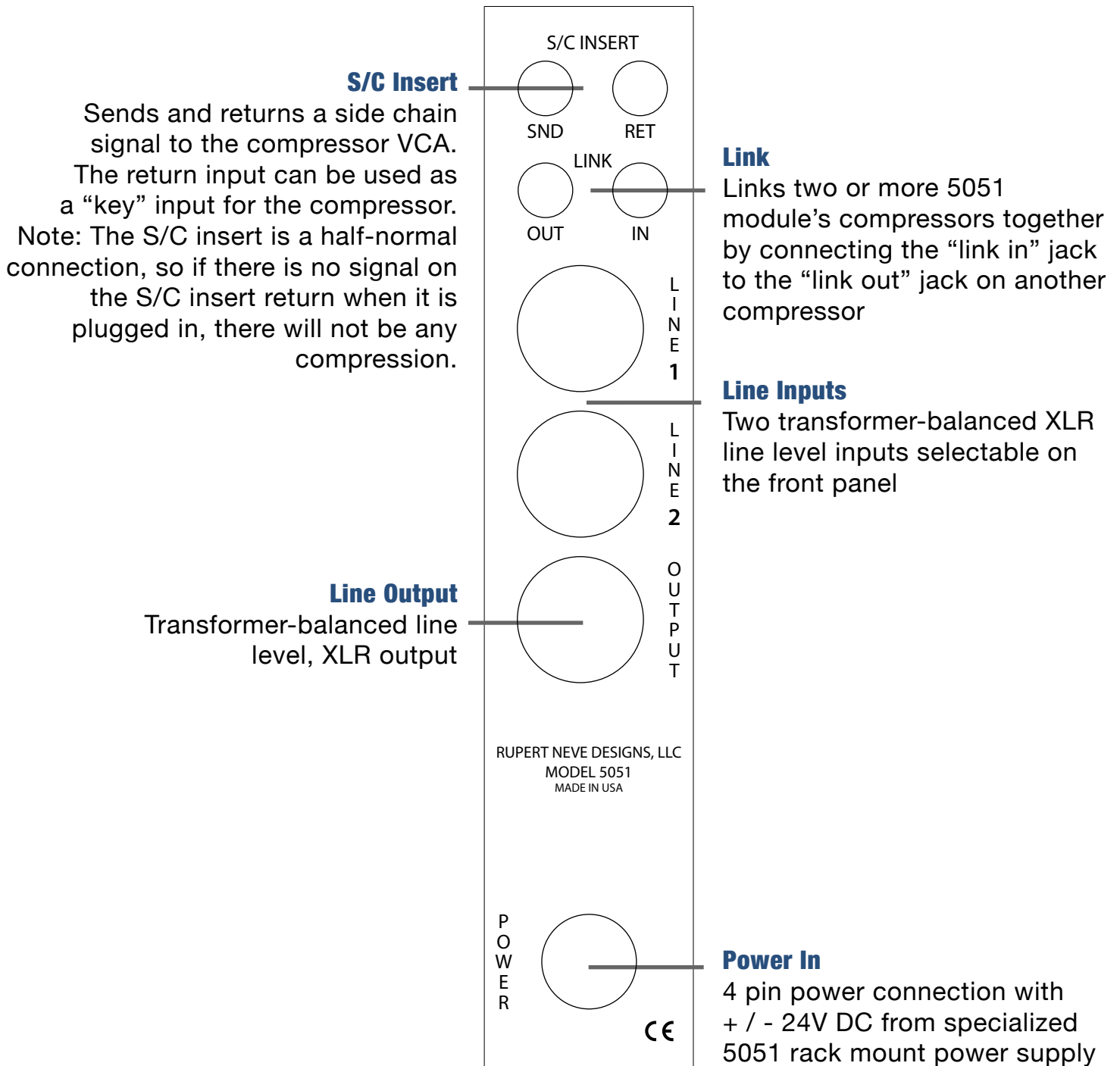

5051: Block Diagram

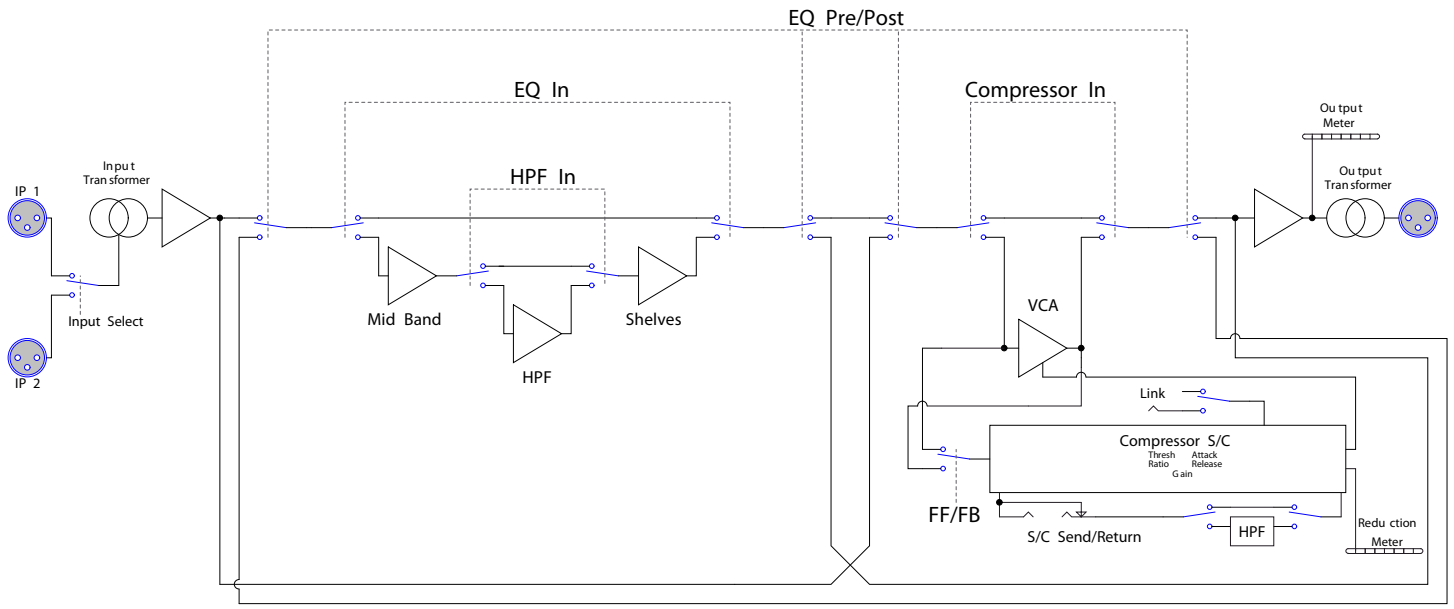

THE NEED FOR DYNAMIC CONTROL OF SOUND LEVELS

The dynamic range of sounds we hear around us in normal life greatly exceeds the capability of our best recording and processing equipment - but even if this were not so, the scale of dynamic range must be accommodated to the venue in which it is to be reproduced. For example, actual volume levels of the dance hall would be deafening in a student's bedroom. In the same way, late night listening in a quiet living room demands careful adjustment of dynamic range. In the constantly changing background noise of a car, drama dialog does not work without constant attention to the level control. In the field of communications, it is often necessary to ensure that the best possible signal-to-noise ratio is obtained, in the interest of intelligibility, within the limited performance of, say, a reporter's recording device.

Digital recorders are unforgiving when overloaded. Overload can be avoided with careful use of high ratio compression - on the verge of limiting - with careful choice of time constants. A recording that still sounds "loud" can be produced without non-musical harmonic distortion. A compressor-limiter is one of the most powerful, yet subjective items in the sound engineer's armory. Compression should never be obvious to the listener and this needs intuitive and effective controls on the part of the designer together with considerable skill on the part of the sound engineer.

A NOTE ON DISTORTION

The human hearing system is a remarkably complex mechanism and we seem to be learning more details about its workings all the time. For example, Oohashi demonstrated that arbitrarily filtering out ultrasonic information that is generally considered above our hearing range had a measurable effect on listener's electroencephalo-grams. Kunchur describes several demonstrations that have shown that our hearing is capable of approximately twice the timing resolution than a limit of 20 kHz might imply ($F=1/T$ or $T=1/F$). His peer reviewed papers demonstrated that we can hear timing resolution at approximately with 5 microsecond resolution (20 kHz implies a 9 microsecond temporal resolution,

while a CD at 44.1k sample rate has a best-case temporal resolution of 23 microseconds).

It is also well understood that we can perceive steady tones even when buried under 20 to 30 dB of noise. And we know that most gain stages exhibit rising distortion at higher frequencies, including more IM distortion. One common IM test is to mix 19 kHz and 20 kHz sine waves, send them through a device and then measure how much 1 kHz is generated ($20-19=1$). All this hints at the importance of maintaining a sufficient bandwidth with minimal phase shift, while at the same time minimizing high frequency artifacts and distortions. All of the above and our experience listening and designing suggest that there are many subtle aspects to hearing that are beyond the realm of simple traditional measurement characterizations.

The way in which an analog amplifier handles very small signals is as important as the way it behaves at high levels. For low distortion, an analog amplifier must have a linear transfer characteristic, in other words, the output signal must be an exact replica of the input signal, differing only in magnitude. The magnitude can be controlled by a gain control or fader (consisting of a high quality variable resistor that, by definition, has a linear transfer characteristic.) A dynamics controller - i.e. a compressor, limiter or expander - is a gain control that can adjust gain of the amplifier very rapidly in response to the fluctuating audio signal, ideally without introducing significant distortion, i.e. it must have a linear transfer characteristic. But, by definition, rapidly changing gain means that a signal "starting out" to be linear and, therefore without distortion, gets changed on the way to produce a different amplitude.

Inevitably our data bank of "natural" sound is built up on the basis of our personal experience and this must surely emphasize the importance of listening to "natural" sound, and high quality musical instruments within acoustic environments that is subjectively pleasing so as to develop keen awareness that will contribute to a reliable data bank. Humans who have not experienced enough "natural" sound may well have a flawed data bank! Quality recording equipment should be capable of retaining "natural" sound and this is indeed the traditional measuring stick. And "creative" musical equipment should provide the tools to manipulate the sound to enhance the emotional appeal of the music without destroying it. Memory and knowledge of real acoustic and musical events may be the biggest tool and advantage any recording engineer may possess.

One needs to be very careful when one hears traces of distortion prior to recording because some flavors of distortion that might seem acceptable (or even stylish) initially, may later prove to cause irreparable damage to parts of the sound (for example, "warm lows" but "harsh sibilance") or in louder or quieter sections of the recording. Experience shows that mic preamps and basic console routing paths should offer supreme fidelity otherwise the engineer has little control or choice of recorded "color" and little recourse to undo after the fact. Devices or circuits that can easily be bypassed are usually better choices when "color" is a consideration and this particularly is an area where one might consider comparing several such devices. Beware that usually deviations from linearity carry at least as much long-term penalty as initial appeal, and that one should always be listening critically when recording and generally "playing it safe" when introducing effects that cannot be removed.

1. Tsutomu Oohashi, Emi Nishina, Norie Kawai, Yoshitaka Fuwamoto, and Hishi Imai. *National Institute of Multimedia Education, Tokyo. "High Frequency Sound Above the Audible Range, Affects Brain Electric Activity and Sound Perception" Paper read at 91st. Convention of the A.E.S. October 1991. Section 7. (1), Conclusion.*

2. Miland Kunchur, *Depart of Physics and Astronomy, University of South Carolina. "Temporal resolution of hearing probed by bandwidth restriction", M. N. Kunchur, Acta Acustica united with Acustica 94, 594-603 (2008) (<http://www.physics.sc.edu/kunchur/Acoustics-papers.htm>)*

HOW THE 5051 COMPRESSOR WORKS

A part of the audio signal is rectified and smoothed to produce a suitable control voltage for the VCA, which has to respond very quickly and have low distortion. If the response is too fast, low frequency signals will themselves, be “gain controlled”! If the response is too slow, the signal will overshoot and the first few cycles will not get compressed. The speed and accuracy of the response, known as the “attack”, and the time frame that gain remains under the initial control, known as “release” or “recovery”, play a large part in the way a compressor sounds.

The 5051 uses very accurate, low noise, low distortion VCA having essentially no “signature” of its own. This leaves the designer free to use amplifier and transformer combinations that are well proven and produce the desired sonic quality.

All Rupert Neve Designs modules use input and output transformers and class-A amplifiers to produce the musical “signature” for which they are known. These are factors that enable the 5051 to work unobtrusively within the context of a very high quality audio chain.

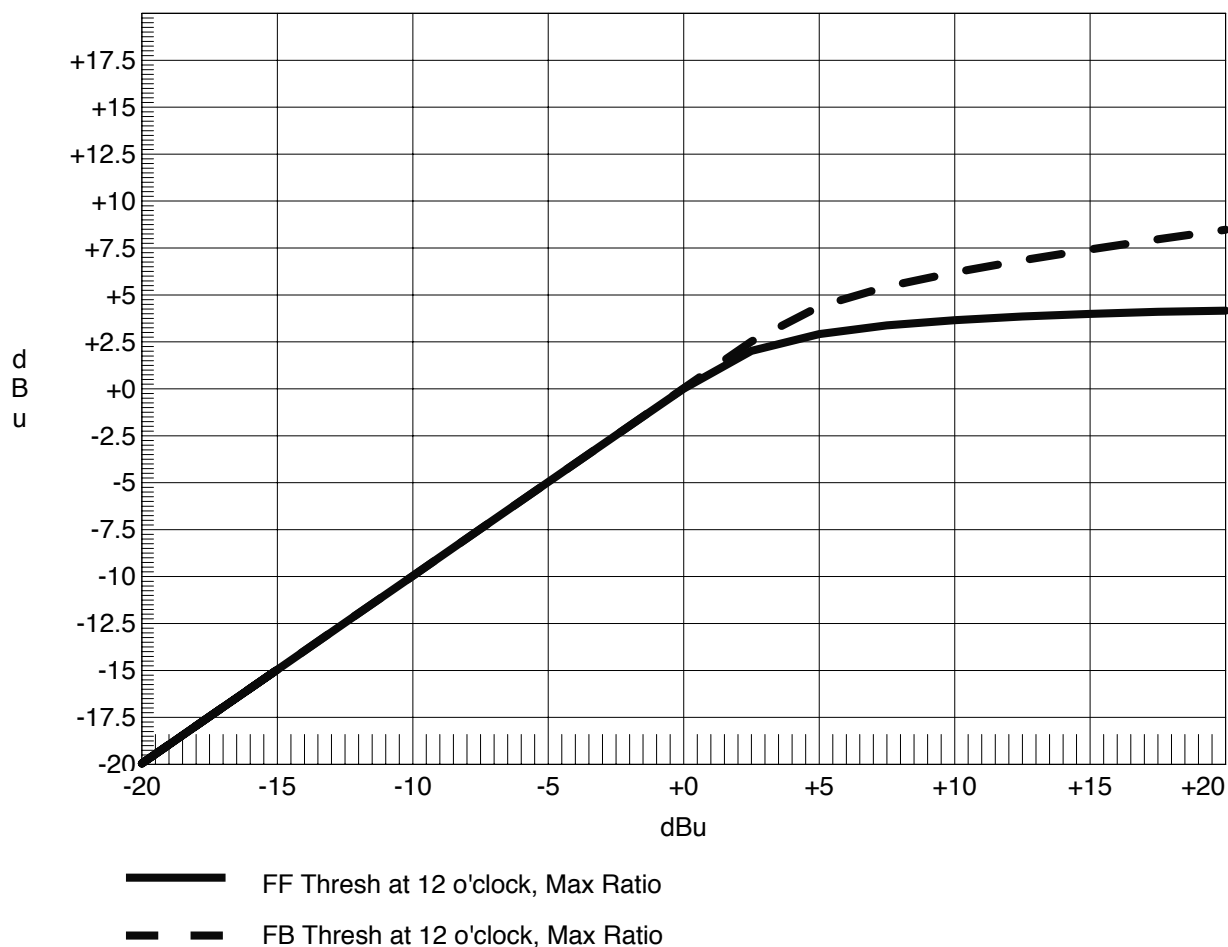

If the VCA control voltage is taken from the 5051 compressor input, (i.e. before the VCA) the VCA

“knows” right away that a gain change is required and there is an almost immediate response. This is known, logically, as a “feed-forward” compressor. If the VCA control voltage is taken from the 5051 compressor output, (i.e. after the VCA) it cannot act immediately on the VCA because it has already been modified by settings of the VCA and circuits through which it has passed. This is known as a “feed-back” compressor. The two compression characteristics are quite different, with both the attack and recovery ramps are changed. Almost all of Mr. Rupert Neve’s earlier designs were “feed-back”.

The way in which these modes change the dynamic performance can be seen in the above graph, but the more interesting effects are noted by listening. “Feed-Back” produces a sweeter, warmer sound but is not as accurate if you need to protect a transmitter, for example.

5051 Design Notes

The RND Model 5051 represents Rupert’s latest addition to the 5088 family. Comprised of a new inductor EQ circuit with a heritage going back decades, and a compressor with elements from the Portico II: Master Buss Processor, the 5051 can be configured within a 5088 console to deliver exceptional tonal and dynamic control on each channel.

Traditional transformer coupled inputs and outputs are used for both technical performance reasons and optimum musical reproduction. The primary signal path uses Class A gain blocks; using as few of these as possible to get the job done. The input circuit uses one gain stage, as does the line driver output. The compressor introduces one stage, the EQ introduces two stages, plus one more if the 18 dB / octave high pass filter is engaged. By combining this minimalistic design aesthetics with class-A gain blocks and custom transformers, the 5051 provides the extraordinary performance and musicality expected from a Rupert Neve design.

The EQ certainly invokes similarities sound-wise with some of Rupert’s classic EQ designs from the seventies. The 5051 repeats history in using a custom tapped inductor and carefully selected capacitor values to form the mid range equalizer band. The 5051 also uses inductors for the low and high EQ, with the shelf curves and frequency choices based on Rupert’s vintage designs. While this method may not be as variable as some of Rupert’s designs of the last 20 years, the “old ways” did have a “sound” that has become rather known and sought after. The use of low-feedback, class-A gain blocks in each EQ section are also an important contributor to the overall sound, preventing low level artifacts and harshness from detracting from the tonal shaping. While these elements make the 5051 much like many of Rupert’s vintage designs, the 5051 takes advantage of techniques that were not possible 35 years ago, and should not be considered a clone of his earlier work. Rather, the 5051 is a culmination of Rupert Neve’s years of experience, expertise, and highly discerning ears, giving this unit a strong sense of Mr. Neve’s design heritage.

Both the high and low band can be switched from shelf to peak curves and offer 15 dB of boost or cut. The high band can be switched from 8 kHz to 16 kHz, and the low band can be selected at 35 Hz, 60 Hz, 100 Hz or 220 Hz. The inductor based Mid Band offers 6 center frequencies; 200 Hz, 350 Hz, 700 Hz, 1.5 kHz, 3 kHz and 6 kHz. The Mid Band also has a “Mid Hi Q” switch to narrow the bandwidth (increase the Q) of the filter. The 5051 includes an 18 dB / octave high pass filter with cutoff frequencies on a button that toggles through “OFF, 60 Hz and 120 Hz” indicated by a blue or red LED respectively.

Additionally, the EQ can be switched Pre or Post the compressor. The 5051 also has two XLR balanced inputs that can be selected from the front panel. This allows the user to have both a mic preamplifier and line input from a DAW pre-patched and easily selectable.

The compressor likewise contains some elements of the past, utilizing Class A gain blocks, mixed with the gain reduction techniques that have been developed over the years and is similar to the Master Buss Processor. The threshold has a range of -30 dBu to +20 dBu. The ratio can be set from 1.1:1 to 40:1. The attack has a range of 5 ms to 75 ms, and the release is variable from 100 ms to 2.5 s to be set. Make-up gain can be set from -6 dB to +20 dB.

The Compressor allows the user to select either a modern feed-forward topology or the traditional feed-back style of compression. Each has advantages depending on the source and desired sound. The 5051 includes a 12 dB/octave 250Hz high pass filter that can be switched into the compressor side-chain to reduce the chance that loud low frequency material inadvertently affects the gain reduction. There is also a link switch and associated 1/4" phone jacks on the back panel so that multiple 5051's can be properly used for stereo. The back panel also features a pair of 1/4" phone jacks to patch in your own EQ into the side-chain for de-essing and finessing the compressor response. The 5051 has two 8 segment fast acting accurate LED bar-graph meters to indicate Gain Reduction and Output Level.

Unlike other modules for the 5088, the 5051 requires its own standalone power supply to operate. The power supply features proprietary 4-pin polarized outputs at +24 and -24V DC, and will power up to twenty-five 5051 modules.

5051 Features

LINE 1 / LINE 2

Allows you to have two sources pre-patched into the 5051. For example you may have an outboard Microphone Pre-Amp patched into Line 1 and a DAC channel from your DAW into Line 2.

EQ IN

Engages all bands of the equalizer except the hpf.

HF

Adjusts up to 15 dB of boost or cut at selected high frequencies.

8K /16K

With the switch out, the center or corner frequency of the high band is 8 kHz. With the button pressed, the center or corner frequency changes to 16 kHz. Between this switch and the HI PEAK switch, you have 4 different EQ curves to finesse the high frequency content.

HI PEAK

When the button is out, the high frequency band operates in shelf mode, boosting or cutting above the corner frequency at approximately 6 dB/octave. Below the corner frequency the amount of boost or cut gradually diminishes. With the HI PEAK button pressed, the high frequency band changes to peak mode with a bell shaped boost or cut curve. The Peak mode utilizes an inductor and capacitor circuit to create the bell-shaped curve.

MID FREQ

The MID FREQ rotary switch has 6 positions to select the center frequency of the mid band EQ stage. This circuit utilizes an inductor and capacitors to shape the EQ curve, the same way as Rupert Neve's

console designs of the 70's. The frequencies chosen are 200 Hz, 350 Hz, 700 Hz, 1.5kHz, 3 kHz and 6 kHz. 200 Hz is especially useful for cuts on individual tracks within a dense mix.

MID HI Q

The resonance or Q of the mid band at maximum boost is typically 2 when the button is out. When the MID HI Q is pressed at maximum boost, the Q narrows to approximately 3.5. The Q widens nicely with less boost or cut as is typical for passive EQ circuits. The Q tends to be slightly wider when the frequency is set lower, and slightly higher for higher frequency selections. The Q is also narrower for cuts than it is for boosts and the mid band is non-symmetrical by design.

MID LEVEL

Adjusts up to 15 dB of boost or cut at the selected mid frequencies. Remember to reduce the signal level at the source to minimize the potential for distortion when any of the 3 bands are boosted significantly.

EQ PRE / POST

Switches the order of the equalizer and compressor sections. With the button out, the equalizer is before the compressor, which means that moderate changes to the EQ settings may require some adjustment of the compressor threshold to maintain a similar amount of compression, or make up gain to maintain a target output level. With the switch pressed in post mode, the EQ follows the compressor. Now moderate changes to the EQ will not affect the compressor, but one may miss having the compressor responding to EQ settings. Also, the EQ will likely have a greater effect on output levels, which may in turn be compensated for with the compressor gain. Each mode has benefits and drawbacks, and many engineers have preferences as to whether they like the EQ pre or post compression.

HPF

Engages an 18 dB per octave Butterworth high pass filter to remove unwanted low frequency sounds. This button actually allows two different corner frequencies. The first press selects a 60 Hz filter denoted by the light illuminating blue. The second press selects a 120 Hz filter denoted by the button illuminating red. The third press cycles the filter back to "off" or "bypass" which extinguishes the LED.

LOW FREQ

The LOW FREQ rotary switch has 4 positions for selecting one of four corner or center frequencies for the low band EQ section. The frequencies are 35 Hz, 60 Hz, 100 Hz and 220 Hz.

LO PEAK

When the button is out, the low frequency band operates in shelf mode, boosting or cutting below the corner frequency. Above the corner frequency the amount of boost or cut gradually diminishes at approximately 6 dB/octave. With the HI PEAK button pressed the low frequency band changes to peak mode with a bell shaped boost or cut curve. Between the LO PEAK button and LO FREQ rotary switch, an engineer has 8 tonal variations of EQ shapes to finesse the bottom end, plus the 2 high pass filter choices can be introduced for further tightening and manipulation.

LF

Adjusts up to 15 dB of boost or cut at the selected low frequencies. Cut can be used as a variable, and perhaps more gentle alternative to using the HPF. Remember to reduce the signal level at the source to minimize the potential for distortion when any of the 3 bands are boosted significantly.

GAIN

Adjusts the final output level of the compressor, and is operationally the same as “Make-Up Gain”. Gain is used to restore the signal back up to a relatively normal level, and is often used to finely control sending the final signal level, for example, to an analog to digital converter.

S/C HPF

Engages a 250Hz, 12dB per octave high pass filter to prevent low frequency material from excessively controlling the compressor. With mixes or wide spectrum sounds, there is often significant amounts of low frequency energy that can cause occasional deep compression, yet it is often the mid frequency sounds that are associated with apparent loudness and the zone that needs compression. The S/C HPF is designed for those situations and 250 Hz is well suited for both vocals and mixes and most other dynamic wide spectrum sounds.

ATTACK

Sets the attack time of the compressor with a range from 5ms to 75 ms. This adjusts the rate that the compressor will reduce gain given the onset of a loud sound. Faster settings will let the compressor respond to quick transients such as the initial hit of a drum and reduce those hits. Slower settings may let the initial transient be relatively untouched but may reduce the part of the drum’s decay, which tends to exaggerate the balance of initial transient to decay. Moderate settings are most useful for preserving the tonal balance of the source, while still effectively taming louder sections of the music.

RELEASE

Sets the release time of the compressor with a range of 100 ms to 2.5 s. When the source signal drops below the threshold after being engaged, the release determines how fast the gain returns to normal. Faster settings tend to be most useful for maximizing loudness, however, there is a greater chance if audible compression, including “pumping” and a slight modulation distortion in the presence of loud low notes. Medium settings are sometimes nice for having the compression act in time with the music. Slow release settings tend to be the least audible and most safe, which may also be said about using lower Ratios, and less compression.

LINK

Allows multiple 5051 modules to be linked together such that at any given time, the 5051 with the highest control voltage will control the compression of all the linked units. To create a stereo pair, first adjust the two modules so that they have identical compression and EQ setting. Then engage the link switch on the front of the left-most 5051.

FF / FB

Selects either feed-forward or feed-back modes of compression. Feed-forward uses the input signal to trigger compression, and feed-back uses a signal from after the gain change element to trigger compression. Feed-forward is often associated with modern compressors and feed-back was generally the method of vintage compressors. Feed-forward typically allows for high ratios, tends to be faster and may offer more dramatic compression effects. Feed-back is often considered to be more traditional, softer, gentler and smoother.

RATIO

Adjusts the ratio of compression above the threshold. The range is from 1.1 to 1 up to 40:1 (in FF mode). Ratio is related to the input signal over the threshold versus the output signal. Lower ratios mean that loud sounds will only cause slight gain reduction and high ratios can cause deep amounts of gain reduction. For example, consider a voice that gets louder than the a threshold by 10 dB, 10:1 will only

let the output rise by 1 dB implying 9 dB of compression, 2:1 will cause the output to increase 5 of those initial 10 dB suggesting 5 dB of reduction. Some engineers relate ratios of 20:1 and higher with limiting, however technically traditional limiting also requires very fast attack times to respond to transients and prevent signals from actually going above a certain level.

COMP IN

Engages the compressor, and is indicated by a green button. Other than simply engaging the compressor, engineers often toggle this button to aid adjusting the make-up gain for similar average levels. The comp in button is also used to compare the untreated signal to the compressed signal to verify a positive change is being made.

THRESHOLD

Sets the level where the compressor begins to react and respond to signals above the set threshold. With the knob set clockwise, only extremely loud signals might cause any gain reduction. With the knob set counter-clockwise, even relatively quiet sounds can cause compression.

GR METER

Indicates how many dB's of gain reduction are happening at a given time. This particularly aids in choosing threshold and ratio settings. While the GR meter is great to confirm what we think we are hearing, usually our listening skills provide a more direct path to choosing compressor settings than meters. The meter will generally indicate very brief gain reductions but will tend to exaggerate the duration so that the eye can see transient compression.

LEVEL METER

Displays the final peak output level of the 5051 regardless of whether the unit is set for EQ PRE or POST. This meter assists adjusting the compressor gain, and helps prevent equipment that the 5051 may be feeding from clipping or overloading. In the case of A to D converters, one should primarily depend on the converters own meters due to possible converter calibration variables. The 5051 level meter is calibrated for dBu, and the red LEDs may not necessarily match up with the destination device. It is often advisable to maintain levels 10 to 20 dB below the destination's maximum input for ease of later processing.

S/C INSERT SND

A 1/4" unbalanced phone jack used to send the signal to an external device, primarily EQ, to create a key signal (it can be any old EQ or device since the audio isn't effected). For example, you may EQ the signal, cutting all the lows and boosting somewhere between 5 kHz and 8 kHz to cause the compressor to respond to frequencies associated with sibilance, and become a de-esser. An engineer can also gently reduce lows and increase mid highs so that the compressor may respond similarly to how our ears may perceive apparent loudness.

S/C INSERT RET

A 1/4" phone unbalanced input jack that is receives the signal from the external device described above. The S/C insert return may also be used as a key input. For example, an engineer might wish to patch in a kick drum to control the compression happening on a bass guitar being run through the 5051.

IMPORTANT NOTE: The S/C insert return is a half-normal connection, meaning that if a plug is inserted into the jack, it will interrupt the S/C signal path, and whatever signal is present on the plug will now be the controlling the compressor side-chain, i.e., if there is no signal present on the plug, there will be no

compression.

LINK IN / OUT

1/4" phone jacks on the back used to connect the compressor VCAs.

The suggested setup for linking multiple units is to do the following:

On the back panel of the left most 5051, plug the link cable into the link out jack. Plug the other end of the cable into the link in jack of the 5051 to its right. In the same way, connect all of the 5051 units together.

LINE 1

XLR female transformer balanced floating input associated with the LINE 1 position of the front panel input switch. Pin 2 high, 10 k Ohm input impedance.

LINE 2

XLR female transformer balanced floating input associated with the LINE 2 position of the front panel input switch. Pin 2 high, 10 k Ohm input impedance.

OUTPUT

XLR male transformer coupled floating output. Pin 2 high, less than 50 Ohm output impedance.

POWER

Proprietary 4 pin polarized input for +24 and -24V DC power input. This power requirement and connector is meant to be used with a special shared power supply.

Specifications

Line In

Frequency Response:

Main Output, no load,
-3 dB @ 2.5 Hz
-3 dB @ 125 kHz

Noise:

Measured at Main Output, unweighted, 22Hz-22kHz,
Terminated 40 Ohms, With gain at unity
better than -102 dBu

Maximum input:

from 20 Hz to 20 kHz,
+25 dBu.

Maximum output:

from 20 Hz to 20 kHz is
+25 dBu.

Total Harmonic Distortion and Noise:

from <10 Hz to 80 kHz,
@ 1kHz, +20 dBu output: Better than 0.002%
@ 20Hz, +20 dBu out Better than 0.120%

@ 20kHz, +20 dBu out Better than 0.010%

Equalizer

Noise:

Measured at Main Output, unweighted, 22Hz-22kHz,
Terminated 40 Ohms. with all gains set at 0,
Better than -92 dBu

Maximum input:

from 20 Hz to 20 kHz,
+24.5 dBu

Maximum output:

from 20 Hz to 20 kHz,
+24.5 dBu

Total Harmonic Distortion and Noise:

from <10 Hz to 80 kHz,
@ 1kHz, +20 dBu output: Better than 0.007%
@ 20Hz, +20 dBu out Better than 0.120%
@ 20kHz, +20 dBu out Better than 0.070%

The Compressor

(Threshold at +20 dB, Ratio at 1.1:1, Gain at 0)

Noise:

Measured at Main Output, unweighted, 22Hz-22kHz,
Terminated 40 Ohms.
Better than -92 dBu

Maximum input:

from 20 Hz to 20 kHz,
+25 dBu.

Maximum output:

from 20 Hz to 20 kHz,
+25 dBu.

Total Harmonic Distortion and Noise:

from <10 Hz to 80 kHz
@ 1kHz, +20 dBu output: Better than 0.020%
@ 20Hz, +20 dBu output Better than 0.140%
@ 20kHz, +20 dBu output Better than 0.070%

Threshold:

Continuously Variable from -30dBu to +20dBu

Ratio:

Continuously Variable from 1.1:1 to 40:1

Gain:

Continuously Variable from -6 dB to +20 dB

Attack:

Continuously Variable from 20 mS to 75 mS

Release:

Continuously Variable from 100mS to 2.5 Seconds

High Pass Filter

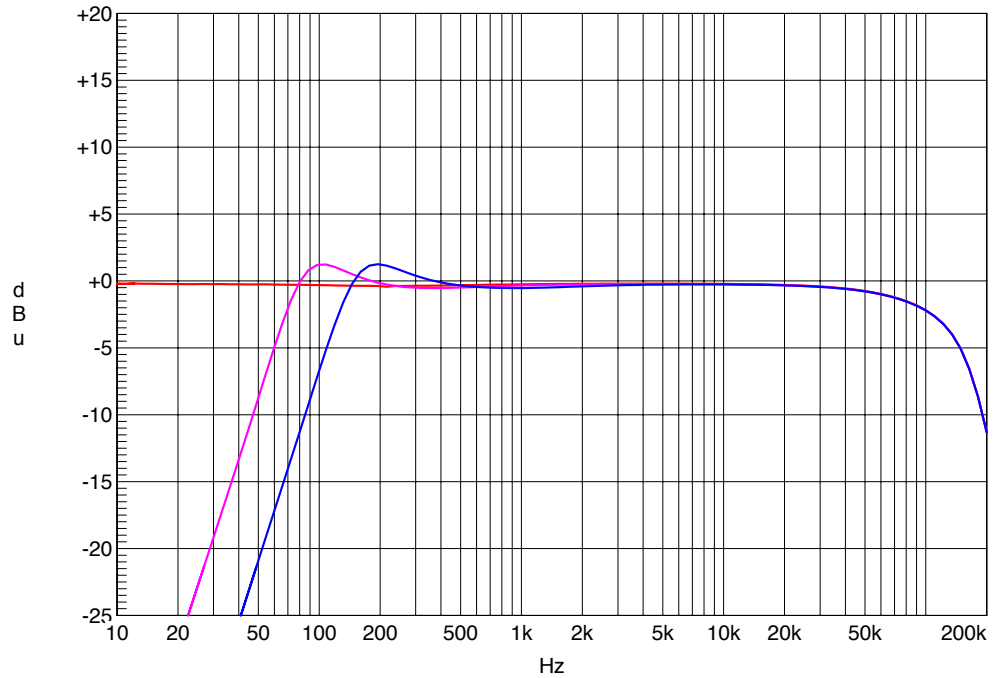

Sweep	Trace	Color	Line Style	Comment
1	1	Red	Solid	Bypass
2	1	Magenta	Solid	60 Hz
3	1	Blue	Solid	120 Hz

Low Frequency EQ

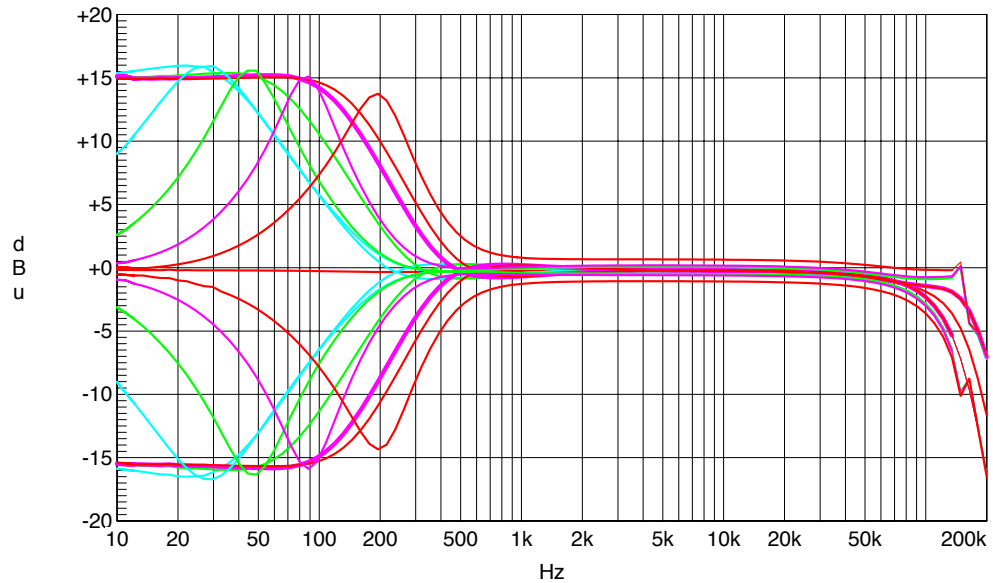

Sweep	Trace	Color	Comment
1	1	Red	EQ Flat
2	1	Cyan	35 Hz Full Boost
3	1	Cyan	35 Hz Full Cut
4	1	Green	60 Hz Full Boost
5	1	Green	60 Hz Full Cut
6	1	Magenta	100 Hz Full Boost
7	1	Magenta	100 Hz Full Cut
8	1	Red	220 Hz Full Boost
9	1	Red	220 Hz Full Cut

Mid Band EQ

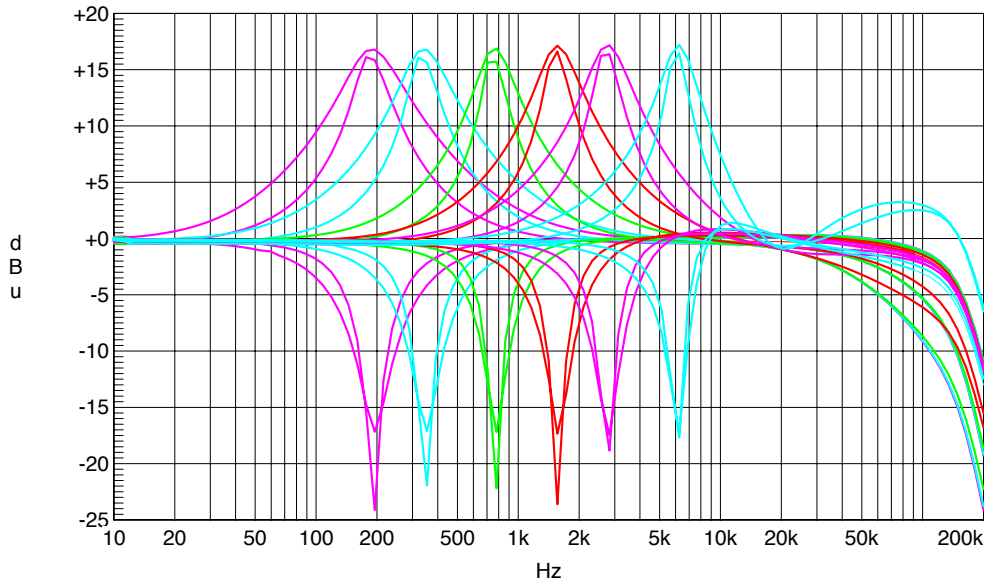

Sweep	Trace	Color	Comment
1	1	Red	Flat
2	1	Magenta	200 Hz Full Boost
3	1	Magenta	200 Hz Full Boost Hi Q
4	1	Magenta	200 Hz Full Cut
5	1	Magenta	200 Hz Full Cut Hi Q
6	1	Cyan	350 Hz Full Boost
7	1	Cyan	350 Hz Full Boost Hi Q
8	1	Cyan	350 Hz Full Cut
9	1	Cyan	350 Hz Full Cut Hi Q

High Frequency EQ

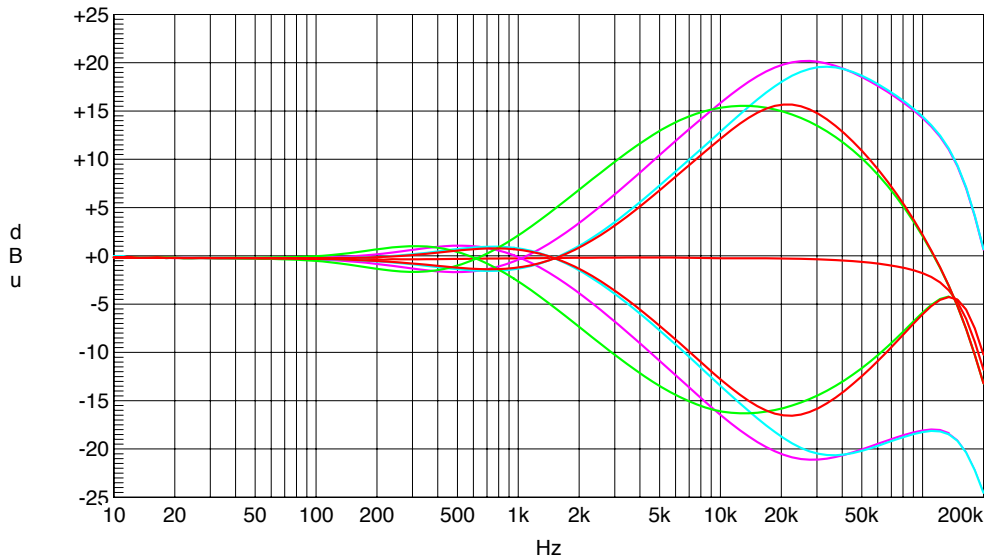

Sweep	Trace	Color	Comment
1	1	Red	Flat
2	1	Magenta	8K Shelf Full Boost
3	1	Magenta	8K Shelf Full Cut
4	1	Cyan	16K Shelf Full Boost
5	1	Cyan	16K Shelf Full Cut
6	1	Green	8K Peak Full Boost
7	1	Green	8K Peak Full Cut
8	1	Red	16K Peak Full Boost
9	1	Red	16K Peak Full Cut

PRODUCT WARRANTY

Rupert Neve Designs warrants this product to be free from defects in materials and workmanship for a period of one (1) year from date of purchase, and agrees to remedy any defect identified within such one year period by, at our option, repairing or replacing the product.

LIMITATIONS AND EXCLUSIONS

This warranty, and any other express or implied warranty, does not apply to any product which has been improperly installed, subjected to usage for which the product was not designed, misused or abused, damaged during shipping, damaged by any dry cell battery, or which has been altered or modified in any way. This warranty is extended to the original end user purchaser only. A purchase receipt or other satisfactory proof of date of original purchase is required before any warranty service will be performed. THIS EXPRESS, LIMITED WARRANTY IS IN LIEU OF ALL OTHER WARRANTIES, EXPRESS OR IMPLIED, TO THE EXTENT ALLOWED UNDER APPLICABLE STATE LAW. IN NO EVENT SHALL RUPERT NEVE DESIGNS BE LIABLE FOR ANY SPECIAL, INCIDENTAL, OR CONSEQUENTIAL DAMAGES RESULTING FROM THE USE OF THIS PRODUCT. Some states do not allow the exclusion or limitation of consequential damages or limitations on how long an implied warranty lasts, so this exclusion may not apply to you.

WARRANTY SERVICE

If you suspect a defect in this product, please call us at 512-847-3013 or email us at support@rupertneve.com to discuss the suggested defect (it is possible that a suspected defect could be due to improper usage) and to obtain a return authorization number. It shall be your responsibility to pay for shipping the product to us, and, if the product is determined to be defective, our responsibility to pay for shipping the product back to you.



Rupert Neve Designs

PO Box 1969

Wimberley TX 78676

www.rupertneve.com

tel: +1 512-847-3013

fax: +1 512-847-8869