

# Lowell Pull-out Rack – 19"D

## Description:

The LPOR pull-out rack was designed for built-in wall and millwork applications and features heavy-duty slides for smooth pull-out access to rackmounted equipment. The 14-ga. steel base installs with screws and can be mounted flush or recessed up to two-inches in a boxed wall or cabinetry to allow room for equipment protrusions. When equipment is in place and wired, the assembly is secured in a fixed position with two screws through a perforated front security panel. The security panel can be removed to facilitate wiring and servicing, allowing the rack to be pulled out from the wall or millwork.

The rack ships unassembled in two boxes. Box one contains the rack bottom and base. Box two contains four corner-post mounting rails (two of which are 7U), three cable lacing bars, a perforated front/bottom security cover, a perforated front/top vent panel and hardware.

## Features:

- Versatile low-cost rack for built-in applications is made in the USA with 100% certified US steel.
- 14-ga. steel base is engineered with two or four slides for pull-out access to equipment.
- Load ratings:  
Racks with two slides support up to 125 lbs.  
Racks with four slides support up to 250 lbs.
- Four corner post rails are 11-ga. steel tapped 10-32. Rear rails are 7U for all models, front rail height varies by model.
- Two side stiffeners provide torsion rigidity.
- Three cable lacing bars facilitate organized cable management.
- Front/bottom security panel is perforated to match front/top ventilation panel and screws into position to deter slide out access to equipment.
- Black powder epoxy finish.
- Ships unassembled in two cartons.



The LPOR rack ships unassembled in two cartons for cost effective shipping.

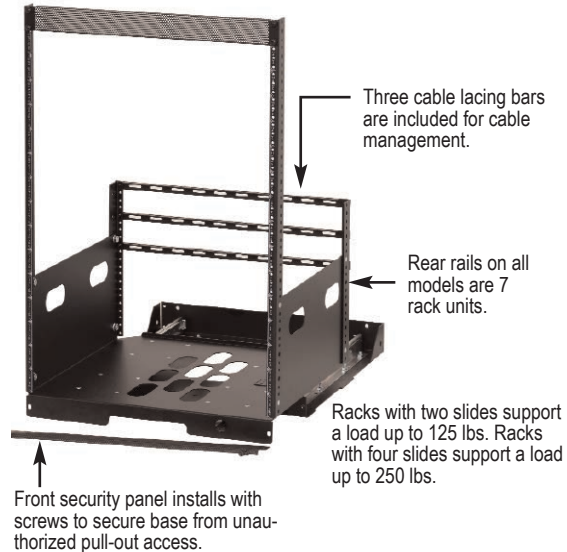

## A & E Specifications:

The rack for built-in application shall be Lowell Model \_\_\_\_\_. It shall be 19.06" wide and 19.22" deep. Panel space shall be \_\_\_\_\_ rack units. The rack shall be made with certified U.S. steel (14-ga. steel base; 11-ga. steel rails tapped 10-32) and have a black powder epoxy finish. The rack shall include \_\_\_\_\_ (two or four) heavy duty slides, allowing it to slide forward on its base while supporting a load up to \_\_\_\_\_ (125 lbs. or 250 lbs.). The rack shall include three cable lacing bars, two side stiffeners, a perforated front/bottom security panel, and a perforated front/top ventilation panel. Rack shall ship unassembled in two cartons.

Model No.	Description	Slide Qty	Rack Units*	Overall D	Panel Space	Overall H	Overall W	Load Capacity
LPOR2-719	Lowell Pull-out Rack	2	7	19.22"	12.25"	14.12"	19.06"	125 lbs.
LPOR2-1019	Lowell Pull-out Rack	2	10	19.22"	17.50"	19.37"	19.06"	125 lbs.
LPOR2-1219	Lowell Pull-out Rack	2	12	19.22"	21.00"	22.87"	19.06"	125 lbs.
LPOR2-1419	Lowell Pull-out Rack	2	14	19.22"	24.50"	26.37"	19.06"	125 lbs.
LPOR2-1619	Lowell Pull-out Rack	2	16	19.22"	28.00"	29.87"	19.06"	125 lbs.
LPOR2-2119	Lowell Pull-out Rack	2	21	19.22"	36.75"	38.62"	19.06"	125 lbs.
LPOR4-719	Lowell Pull-out Rack	4	7	19.22"	12.25"	14.12"	19.06"	250 lbs.
LPOR4-1019	Lowell Pull-out Rack	4	10	19.22"	17.50"	19.37"	19.06"	250 lbs.
LPOR4-1219	Lowell Pull-out Rack	4	12	19.22"	21.00"	22.87"	19.06"	250 lbs.
LPOR4-1419	Lowell Pull-out Rack	4	14	19.22"	24.50"	26.37"	19.06"	250 lbs.
LPOR4-1619	Lowell Pull-out Rack	4	16	19.22"	28.00"	29.87"	19.06"	250 lbs.
LPOR4-2119	Lowell Pull-out Rack	4	21	19.22"	36.75"	38.62"	19.06"	250 lbs.

\*One rack unit (RU or U) = 1.75"

# Lowell Pull-out Rack – 19"D

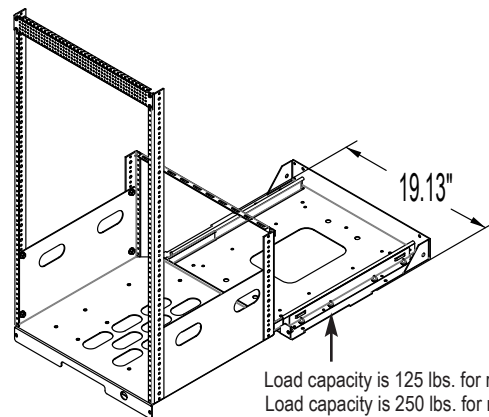
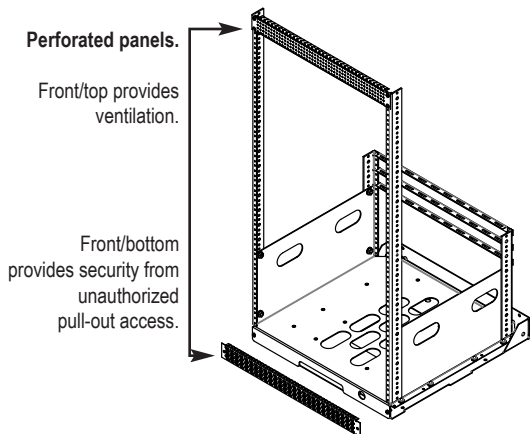
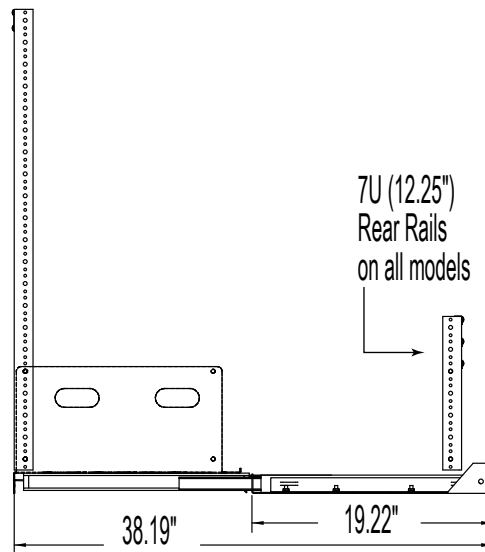
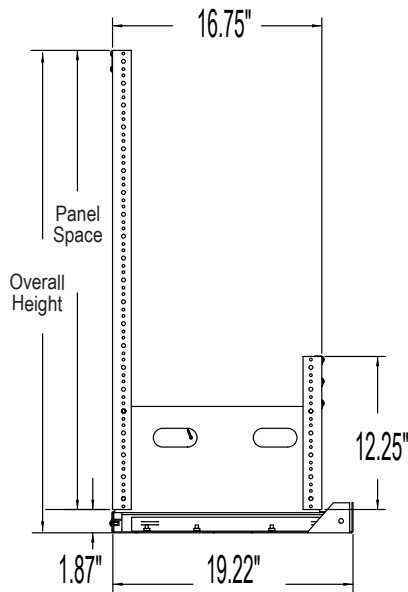
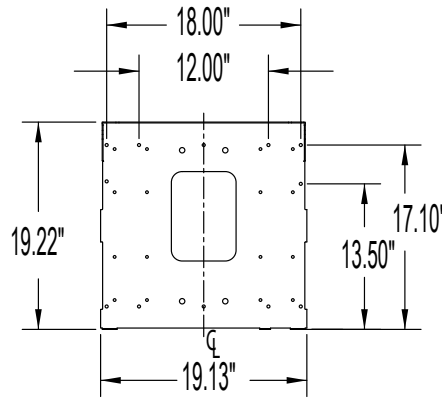
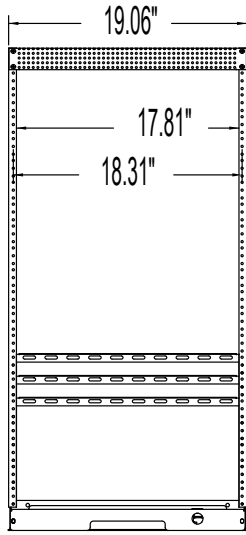

Load capacity is 125 lbs. for racks with 2-slides  
Load capacity is 250 lbs. for racks with 4-slides

All measurements are inches.