



100V 115/120V 230/240V



## GENERAL INFORMATION

ETC's Desire Series D40XTI brings the amazing control of the seven-color x7 system to your facility for permanent installation. With its IP66 rating, this fixture is ready for mounting inside or outside- where ever you need it. The Selador® x7 Color System™ produces the widest range of spectrally-balanced saturated and tinted color choices available. The D40XTI offers a rugged die-cast enclosure, noiseless fan-free operation and multiple lens options that can be changed on site.

### D40XTI LED ARRAY OPTIONS

D40XTI fixtures are based on the x7 Color System that uses seven different LED colors to achieve true, usable broad-spectrum color. The D40XTI luminaire is available with any one of the following x7 color arrays to best suit the intended application.

- D40XTI Vivid™ – the x7 Color System array balanced for best all-around use as a color-changing wash fixture
- D40XTI Lustr+™ – optimized with six colors plus high-intensity white LEDs to create an ideal front light wash fixture. Full range color, with an emphasis on lighter colors and white.
- D40XTI Ice™ – uses the cool colors of the x7 System to provide extra-high brightness color in the blue end of the spectrum
- D40XTI Fire™ – uses the warm colors of the x7 System to provide extra-high brightness color in the red end of the spectrum
- D40XTI Studio HD™ – Studio HD combines warm white and cool white LEDs for variable color temperature mixing. Added to this are five carefully chosen LED colors from the Selador® x7 Color System™ to fill in the white LED spectral gaps. D40XTI Studio HD provides the richest variable white light possible in an LED fixture.

Also available in the following static white arrays.

- D40XTI Studio Daylight™ – Studio Daylight contains forty 5600K LEDs for high-intensity, non-variable cool-white output
- D40XTI Studio Tungsten™ – Studio Tungsten contains forty 3000K LEDs for high-intensity, non-variable warm-white output.

## ORDERING INFORMATION

### Selador D40XTI

MODEL	DESCRIPTION
SELD40XTI-V	D40 Vivid wash fixture – for high-intensity color mixing across the spectrum for widest color wash use
SELD40XTI-L	D40 Lustr+ front light wash fixture – optimized for skin tones and light tints
SELD40XTI-F	D40 Fire special wash fixture – limited palette, high brightness in the red (warm) end of the spectrum
SELD40XTI-I	D40 Ice special wash fixture – limited palette, high brightness in the blue (cool) end of the spectrum
SELD40XTI-H	D40 Studio HD wash fixture – high-intensity variable white light output with broad spectrum richness and color rendering
SELD40XTI-D	D40 Studio Daylight wash fixture – all 5600K emitters for single color, non- adjustable daylight output
SELD40XTI-H	D40 Studio tungsten wash fixture – all 3000K emitters for single color, non- adjustable warm white output

Note: D40XTI luminaires ship with hanging yoke, attached leads and a data termination board. C-clamp, lenses or other accessories are not included.



## SPECIFICATIONS

**GENERAL**

- Easy setup via any RDM device such as ETC Gateways and Gadget
- 40 LED variable color-mixing light wash fixture (color mixing fixtures)
- 40 LED white-light wash fixture (static white fixtures)
- ETL listed to UL1598
- IP66-rated for exterior wet location use
- Data termination board for easy installation (included)

**PHYSICAL**

- Rugged die-cast all-metal housing
- Accessory ring for installation of secondary lenses
- Available in black (standard), white or silver (optional) or custom colors (contact factory)
- Hanging yoke standard.
- Effective Projected Area (EPA): 0.74

**ELECTRICAL**

- 100VAC to 240VAC 50/60 Hz universal power input
- Waterproof, 39" outdoor rated power lead
- Up to 10 fixtures (15A max) may be fed on the same circuit
- Requires power from a non-dim source

**LED\***

- 50,000 hour LED life (50,000 hours to 70% intensity)
- 40 Luxeon® Rebel LED emitters
- Studio Daylight and Studio Tungsten use Rebel ES white light emitters for higher output

\*See additional LED notes on page three

**COLOR**

- Exclusive x7 *Color System*™ seven-color LED array
- Broad spectrum color interacts seamlessly with conventional sources
- Beautifully illuminates skin tones and other objects for natural appearance and high color rendering
- Exclusive red-shift option emulates tungsten dimming performance (not available on static white fixtures)
- Studio HD array uses warm and cool white light emitters with additional deep color emitters
- Studio Tungsten and Studio Daylight provide good color rendering at very high brightness

**OPTICAL**

- Primary field angle of 17° and beam angle of 8°
- Secondary lenses available for multiple beam spread options
- Lenses must be ordered separately
- Refer to accessories chart for lenses available

**CONTROL**

- DMX512 in and thru via termination board (included)
- See DMX Control Table for operation modes
- 15-bit virtual dimming engine provides smooth, high quality theatrical fades and minimizes color shift during dimming
- RDM functionality for address and setting changes

## SPECIFICATIONS

**THERMAL**

- Ambient operating temperature of -4° to 104°F (-20° to 40°C)
- Active electronic thermal management for droop-free operation
- Noiseless, fan-free convection cooling for acoustically sensitive installations
- Fixture is designed for continuous operation up to 104°F (40°C) ambient temperature and requires free flow of air around fixture housing

## ADDITIONAL ORDERING INFORMATION

**Fixtures Accessories**

MODEL	DESCRIPTION
D40XTIWM	Wall Mount Kit (black)
D40XTIWM-1	Wall Mount Kit (white)
D40XTISPM	Single Pole Mount Kit (black)
D40XTISPM-1	Single Pole Mount Kit (white)
D40XTIDPM	Double Pole Mount Kit (black)
D40XTIDPM-1	Double Pole Mount Kit (white)
D40XTIL	Egg Crate (black)
D40XTIL-1	Egg Crate (white)
D40XTIHH	Half Shield (black)
D40XTIHH-1	Half Shield (white)
400CC	C-Clamp (does not ship with fixture)
400SC	Safety Cable (32")

ADDITIONAL ORDERING INFORMATION

Secondary Lens Options

MODEL	DESCRIPTION: The following lenses are cut for D40XTI™ fixtures and create round, linear or oblong field patterns as described below. These lenses are not for use in Selador® Classic (Vivid™, Lustr®, Paletta™, etc.) fixtures.	
<b>Narrow Linear Field</b>	Note: This is the same material as Selador Classic lenses	
D40XTI-LVN	Very Narrow lens	Linear lenses may be combined to create desired field size
D40XTI-LN	Narrow lens	
D40XTI-LM	Medium lens	
D40XTI-LW	Wide lens	
D40XTI-LXW	Extra Wide lens	
<b>Round Field</b>	Any one of the following round lenses may be installed permanently in the fixture at the factory as a special order	
D40XTI-RVN	Very Narrow lens (round field)	
D40XTI-RN	Narrow lens (round field)	
D40XTI-RM	Medium lens (round field)	
D40XTI-RW	Wide lens (round field)	
D40XTI-RXW	Extra Wide lens (round field)	
<b>Oblong Field</b>		
D40XTI-ON	Narrow lens (oblong field)	
D40XTI-OM	Medium lens (oblong field)	
D40XTI-OW	Wide lens (oblong field)	

Typical Lens Field Profiles

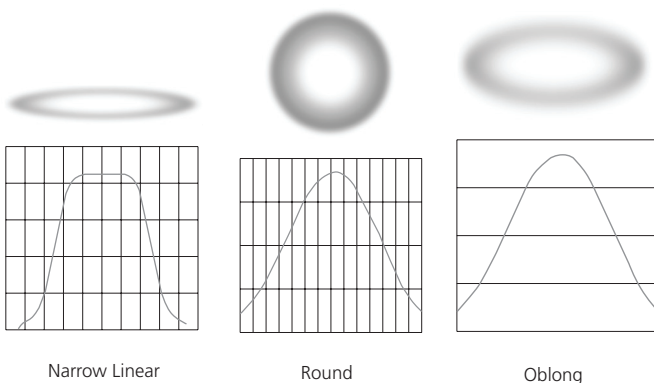

Power Consumption at Full Intensity

MODEL	VOLTAGE (V)	CURRENT (A)	WATTS
D40XTI	120 / 240	1 / .5	110

NOTES ABOUT LED LUMINAIRES

All LED sources experience some lessening of light output and some color shift over time. LED output will vary with thermal conditions. Thermal conditions can be effected by ambient temperatures and orientation. See the D40 Ambient Temperature and Power Budgeting Guide for more details. Based on the LED manufacturer's B50 L70 specification, a Selador luminaire will achieve ~70% of its initial output after 50,000 hours of typical usage. In individual situations, LEDs will be used for different durations and at different levels. This can eventually lead to minor alterations in color performance, necessitating slight adjustment to presets, cues or programs.

CRI AND CQS RATINGS

Desire fixtures were evaluated for CRI and CQS performance using measured output spectrum and optimized mix solutions for a best spectral match to black body sources at 3200K and 5600K.

Fixture	CRI	CQS	Color Fidelity	Duv
D40 Vivid™ at 3200K	87	89	89	0.000
D40 Vivid at 5600K	90	92	92	0.000
D40 Lustr+™ at 3200K	86	88	88	0.000
D40 Lustr+ at 5600K	93	92	90	0.000
D40 Studio HD™ at 3200K	89	90	91	0.000
D40 Studio HD at 5600K	92	94	94	0.000
D40 Studio Daylight™ at 5600K	71	70	69	0.001
D40 Studio Tungsten™ at 3000K	86	86	86	0.001

All D40XTI Studio luminaire versions provide excellent color rendering to the eye, particularly at higher color temperature settings such as 5600K. In most cases the Duv is 0.000. A Duv rating of 0.000 indicates that the color mix used is exactly on the black body line, with no green or magenta tint.

Notes to Videographers:

- All Desire fixtures use Luxeon Rebel ES emitters specified by the strictest binning standards. However, on-camera LED response varies with different cameras and settings. Daylight LEDs can appear slightly greener than other 5600K sources on camera.
- Fixtures with non-variable single-color daylight arrays such as Studio Daylight may use standard color correction filters (Rosco 3314, Rosco 3316 or similar) to achieve the desired on-camera result.
- Camera tests using your specific set up are recommended to determine the best configuration.

CONTROL OPTIONS

User settings on D40XT fixtures allow multiple operational modes and settings for either console operation via DMX protocol or stand-alone operation. The expanded LCD display provides easy navigation to all possible settings and choices. Some of the setting options are:

- Multiple DMX options ranging from a simple RGB profile – which effectively controls all seven LED colors via three channels – to nine-channel ‘direct’ color and intensity control
- Multiple dimming curve options
- Preset colors and sequences for stand-alone (no console required) operation
- White point selection – white light and color behavior based on a specific color temperature white light, i.e. 3200K, 5600K, etc
- Loss of data behavior options – instant off, hold last look for two minutes, etc.
- Output modes – Three output options that offer the user a choice between maximum output and maximum consistency

See the user manual for a complete explanation of all of the control settings and options for the D40XTI

Quick Setups

To assist in managing the numerous control and fixture behavior choices, five combinations of operational settings are available to quickly get started. These settings are specifically created for different applications and are easily accessible at the fixture display. Each setting can then be modified as required to take advantage of all of the possible control features.

Setting Title	Profile	Description	Typical Features*
General	Direct	Factory Default: For general purpose use including interior architectural applications.	<ul style="list-style-type: none"> <li>• Standard dimming curve</li> <li>• Regulated output for color consistency</li> </ul>
Stage	HSI Plus 7 Enabled	Theatrical lighting: Duplicates the color and dimming behavior of tungsten stage lighting fixtures.	<ul style="list-style-type: none"> <li>• Incandescent dimming curve</li> <li>• Regulated output for color consistency</li> <li>• 3250K white point setting</li> </ul>
XT Arch	HSI	Exterior Architectural lighting: Provides a high degree of color consistency in high ambient temperature environments.	<ul style="list-style-type: none"> <li>• Standard dimming curve</li> <li>• Protected output</li> <li>• 3200K white point setting</li> </ul>
High Impact	RGB	Event lighting: Enables quickest response, simple RGB control and strobe channel for maximum effect usage.	<ul style="list-style-type: none"> <li>• Quick dimming curve</li> <li>• Boost mode for maximum intensity</li> <li>• 5600K white point setting</li> </ul>
Studio	Studio	Video/film lighting: Enables three parameter control of white light (intensity, white point, and tint) via DMX from console or from fixture display – no console required.	<ul style="list-style-type: none"> <li>• Linear dimming curve</li> <li>• Regulated output mode for color consistency</li> </ul>

\*See user manual for complete list of features for each Quick Setup.

CONTROL OPTIONS

DMX Input Channel Profiles

DMX Profile	DMX Channels	Channel Assignments	Notes
Direct	9	1 – Red 2 – Orange (white if Lustr+) 3 – Amber 4 – Green 5 – Cyan 6 – Blue 7 – Indigo 8 – Intensity 9 – Strobe	Direct control of each individual color with a separate master intensity channel. Color calibration of LEDs is not active in this mode. The nine-channel profile will produce the highest quality color cross-fades.
HSI	5	1 – Hue (coarse) 2 – Hue (fine) 3 – Saturation 4 – Intensity 5 – Strobe	High resolution hue (two-channels), saturation, and intensity control. HSI mode will produce color cross-fades around the color space.
HSIC	6	1 – Hue (coarse) 2 – Hue (fine) 3 – Saturation 4 – Intensity 5 – Strobe 6 – Color Point (CCT)	High-resolution hue, saturation and intensity control as above, with the addition of a color point channel to adjust the color temperature of the fixture in both white light and color. Color cross-fade performance is the same as EHSI.
RGB	5 (Ch. 4 not used)	1 – Red 2 – Green 3 – Blue 4 – n/a 5 - Strobe	Effectively addresses all seven colors via three channels of control. RGB profile will produce medium quality color cross-fades.
Studio	3	1 – Intensity 2 – Color Point (CCT) 3 – Tint	Controls fixture as a white light unit. If no DMX, i.e. console input, is present, fixture can be adjusted for these three parameters on the U/I at the back of the unit.
Additional profile options			
Plus 7		Seven additional color control channels are available in RGB, HSI, HSIC, and Studio profile settings. For example HSI with ‘Plus 7’ enabled becomes a 14-channel profile:	
		1 – Hue (coarse) 2 – Hue (fine) 3 – Saturation 4 – Intensity 5 – Strobe 6 – n/a 7 – Plus 7 Control on/off 8 – Red 9 – Orange (white if Lustr+) 10 – Amber 11 – Green 12 – Cyan 13 – Blue 14 – Indigo	<p>The desired color and intensity is achieved by using the HSI or RGB channels.</p> <p>Placing channel seven at a value over 51% gives the fixture a 14-channel profile.</p> <p>Channels 8-14 represent the native colors of the fixture and allow the operator to adjust individual color channels to fine tune the color output.</p>
Strobe		Variable strobe control: 0% is no strobe. The fixture output will strobe more rapidly as the strobe channel value approaches 100%.	

## CONTROL OPTIONS

## Studio Daylight and Studio Tungsten (only)

## Quick Set-Ups

Setting Title	Profile	Description	Typical Features*
Studio	Studio	Simple mode for linear intensity control	<ul style="list-style-type: none"> <li>• Linear dimming curve</li> <li>• Regulated output for intensity stability</li> </ul>
Single Channel	Direct	For general purpose architectural use	<ul style="list-style-type: none"> <li>• Standard dimming curve</li> <li>• Regulated output for consistency</li> </ul>
Stage	Direct	Matches conventional luminaire performance	<ul style="list-style-type: none"> <li>• Incandescent dimming curve</li> <li>• Regulated output</li> </ul>

## CONTROL OPTIONS

## DMX Input Channel Profiles

DMX Profile	DMX Channels	Channel Assignments	Notes
Studio	3	1 – Intensity 2 – Strobe 3 – N/A - only used in D60	Control of parameters is also enabled from the luminaire's user interface. No console required.
Direct	3	1 – Intensity 2 – Strobe 3 – N/A - only used in D60	

PHOTOMETRICS

D40XTI Vivid™

Mode	Degree	Candela	Field Lumens	Beam Lumens	Lumens Per Watt
Boost - Cold	17°	101,900	2,540	1,200	26.7
Regulated	17°	87,200	2,150	1,020	26.5

Metric Conversions: For Meters multiply feet by .3048  
For Lux multiply footcandles by 10.76

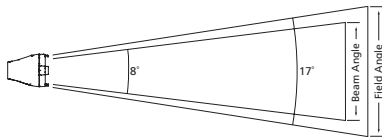

<b>Throw Distance (d)</b>	10.0' 3.0m	15.0' 4.6m	20.0' 6.1m	25.0' 7.6m	319' 97m
<b>Field Diameter</b>	3.1' 0.9m	4.6' 1.4m	6.2' 1.9m	7.7' 2.3m	-
<b>Illuminance (fc)</b>	1,1019	453	255	163	1
<b>Illuminance (lux)</b>	10,968	4,875	2,742	1,755	10.76

For field diameter at any distance, multiply distance by .308  
For beam diameter at any distance, multiply by 0.145

Cosine Candela Plot

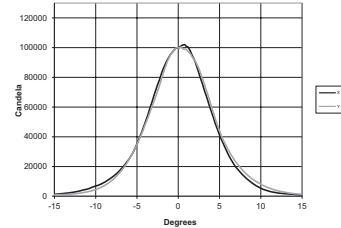

Iso-Illuminance Diagram (Flat Surface Distribution)

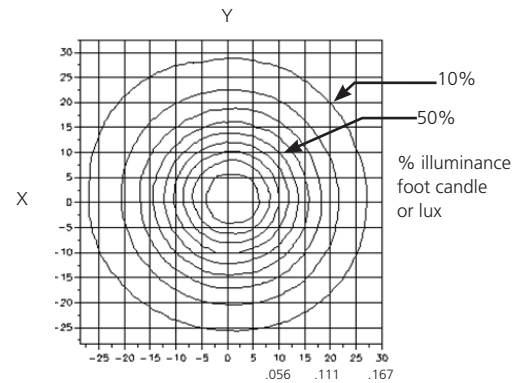

D40XTI Lustr+™

Mode	Degree	Candela	Field Lumens	Beam Lumens	Lumens Per Watt
Boost - Cold	17°	121,500	2,980	1,450	30.3
Regulated	17°	109,100	2,680	1,300	29.8

Metric Conversions: For Meters multiply feet by .3048  
For Lux multiply footcandles by 10.76

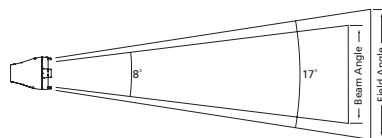

<b>Throw Distance (d)</b>	10' 3.0m	15.0' 4.6m	20.0' 6.1m	25.0' 7.6m	348' 106m
<b>Field Diameter</b>	3.0' 0.9m	4.5' 1.4m	6.0' 1.8m	7.5' 2.3m	-
<b>Illuminance (fc)</b>	1,215	540	304	194	1
<b>Illuminance (lux)</b>	13,078	5,813	3,270	2,093	10.76

For field diameter at any distance, multiply distance by .301  
For beam diameter at any distance, multiply by 0.145

Cosine Candela Plot

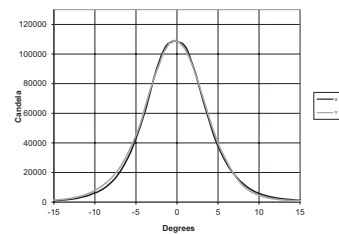

Iso-Illuminance Diagram (Flat Surface Distribution)

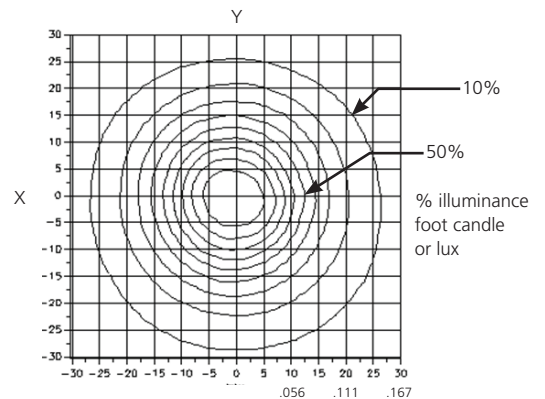

PHOTOMETRICS

D40XTI Fire™

Mode	Degree	Candela	Field Lumens	Beam Lumens	Lumens Per Watt
Boost - Cold	17°	94,900	2,540	1,200	28.7
Regulated	17°	82,500	2,220	1,040	26.5

Metric Conversions: For Meters multiply feet by .3048  
For Lux multiply footcandles by 10.76

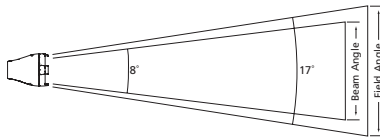

Throw Distance (d)	10.0'	15.0'	20.0'	25.0'	308'
	3.0m	4.6m	6.1m	7.6m	93m
Field Diameter	3.2'	4.8'	6.4'	8.0'	-
	1.0m	1.5m	1.9m	2.4m	-
Illuminance (fc)	949	422	237	152	1
Illuminance (lux)	10,215	4,540	2,554	1,634	10.76

For field diameter at any distance, multiply distance by .318  
For beam diameter at any distance, multiply by 0.148

Cosine Candela Plot

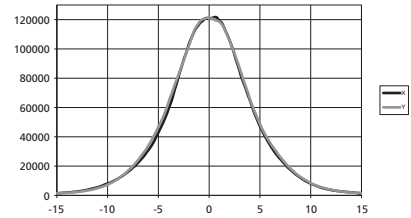

Iso-Illuminance Diagram (Flat Surface Distribution)

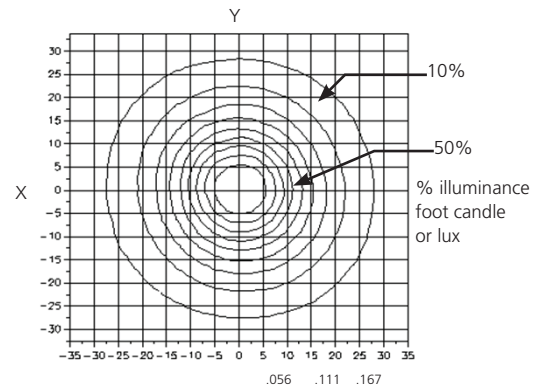

D40XTI Ice™

Mode	Degree	Candela	Field Lumens	Beam Lumens	Lumens Per Watt
Boost - Cold	17°	70,900	1,830	890	18.1
Regulated	17°	63,200	1,630	790	18.0

Metric Conversions: For Meters multiply feet by .3048  
For Lux multiply footcandles by 10.76

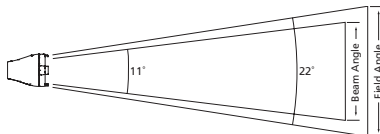

Throw Distance (d)	10.0'	15.0'	20.0'	30.0'	266'
	3.0m	4.6m	6.1m	9.1m	81m
Field Diameter	3.1'	4.6'	6.2'	9.3'	-
	0.9m	1.4m	1.9m	2.8m	-
Illuminance (fc)	709	315	177	79.78	1
Illuminance (lux)	7,632	3,392	1,908	848	10.76

For field diameter at any distance, multiply distance by .310  
For beam diameter at any distance, multiply by 0.147

Throw Distance Multiplier (TDM)

To determine the distance from the center of the beam (Origin) to a certain illuminance level at a particular distance, multiply the desired throw distance by the TDM desired on the Iso-Illuminance diagram.

Throw Distance (TD) x Throw Distance Multiplier (TDM) = Distance from the Origin (DFO) (distance from the center of the beam)

Example: 25 feet (TD) x 0.047 (TDM) = 1.175 feet from center of beam (DFO)

For illumination with any lamp, multiply the candlepower of a beam spread by the multiplying factor (mf) shown for that lamp.

To determine illumination in footcandles or lux at any throw distance, divide candlepower by distance squared.

Cosine Candela Plot

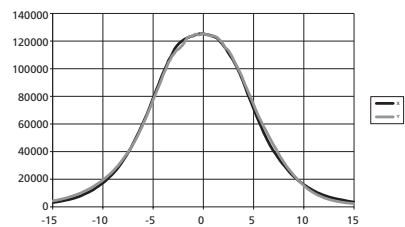

Iso-Illuminance Diagram (Flat Surface Distribution)

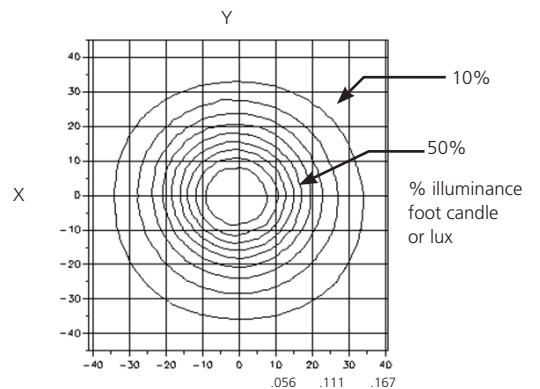

PHOTOMETRICS

D40XTI Studio HD™

Mode	Degree	Candela	Field Lumens	Beam Lumens	Lumens Per Watt
Boost - Cold	17°	121,900	3,120	1,410	30.9
Regulated	17°	109,500	2,780	1,260	30.9

Metric Conversions: For Meters multiply feet by .3048  
For Lux multiply footcandles by 10.76

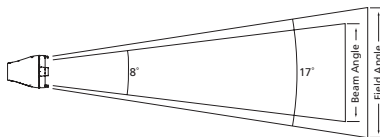

Throw Distance (d)	10.0'	15.0'	20.0'	25.0'	349'
	3.0m	4.6m	6.1m	7.6m	106m
Field Diameter	3.1'	4.7'	6.3'	7.8'	-
	1.0m	1.4m	1.9m	2.4m	-
Illuminance (fc)	1,219	542	305	195	1
Illuminance (lux)	13,121	5,832	3,280	2,099	10.76

For field diameter at any distance, multiply distance by .313  
For beam diameter at any distance, multiply by 0.143

Cosine Candela Plot

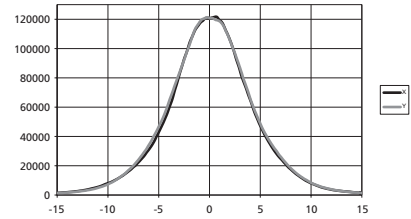

Iso-Illuminance Diagram (Flat Surface Distribution)

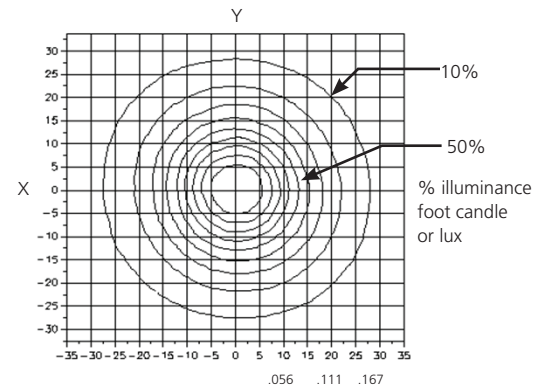

D40XTI Studio Daylight™

Mode	Degree	Candela	Field Lumens	Beam Lumens	Lumens Per Watt
Boost - Cold	22°	125,700	5,380	2,850	52.5
Regulated	22°	125,350	3,440	1,820	56.3

Metric Conversions: For Meters multiply feet by .3048  
For Lux multiply footcandles by 10.76

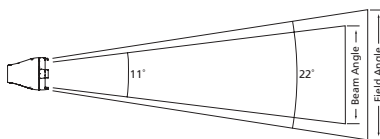

Throw Distance (d)	10'	15'	20'	25'	354'
	3.0m	4.6m	6.1m	7.6m	108.1m
Field Diameter	3.9'	5.8'	7.8'	9.7'	-
	1.2m	1.8m	2.4m	3.0m	-
Illuminance (fc)	1,257	559	314	201	1
Illuminance (lux)	13,530	6,013	3,383	2,165	10.76

For field diameter at any distance, multiply distance by .390  
For beam diameter at any distance, multiply by 0.198

Cosine Candela Plot

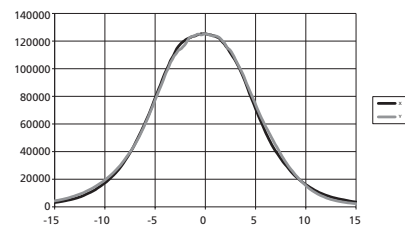

Iso-Illuminance Diagram (Flat Surface Distribution)

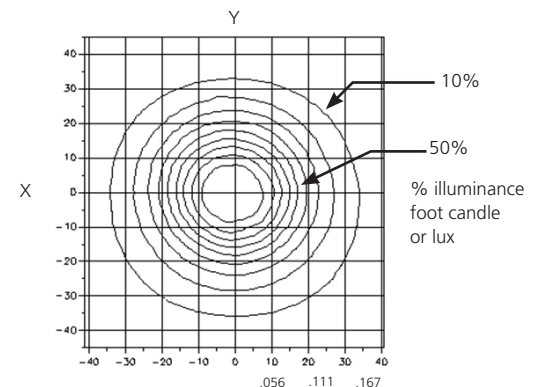



PHOTOMETRICS

D40XTI Studio Tungsten™

Mode	Degree	Candela	Field Lumens	Beam Lumens	Lumens Per Watt
Boost - Cold	24°	9,030	4,105	1,900	40.0
Regulated	24°	79,720	3,514	1,620	36.9

Metric Conversions: For Meters multiply feet by .3048  
For Lux multiply footcandles by 10.76

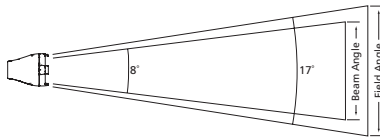

D40XTI Studio Tungsten™

Mode	Degree	Candela	Field Lumens	Beam Lumens	Lumens Per Watt
Boost - Cold	24°	9,030	4,105	1,900	40.0
Regulated	24°	79,720	3,514	1,620	36.9

Metric Conversions: For Meters multiply feet by .3048  
For Lux multiply footcandles by 10.76

Throw Distance (d)	10'	15'	20'	25'	305'
	3.0m	4.6m	6.1m	7.6m	93m
Field Diameter	4.1'	6.2'	8.3'	10.4'	-
	1.3m	1.9m	2.5m	3.2m	-
Illuminance (fc)	930	413	233	149	1
Illuminance (lux)	10,014	4,451	2,503	1,602	10.76

For field diameter at any distance, multiply distance by .414  
For beam diameter at any distance, multiply by 0.189

Throw Distance Multiplier (TDM)

To determine the distance from the center of the beam (Origin) to a certain illuminance level at a particular distance, multiply the desired throw distance by the TDM desired on the Iso-Illuminance diagram.

Throw Distance (TD) x Throw Distance Multiplier (TDM) = Distance from the Origin (Dfo) (distance from the | center of the beam)

Example: 25 feet (TD) x 0.047 (TDM) = 1.175 feet from center of beam (Dfo)

For illumination with any lamp, multiply the candlepower of a beam spread by the multiplying factor (mf) shown for that lamp.

To determine illumination in footcandles or lux at any throw distance, divide candlepower by distance squared.

Cosine Candela Plot

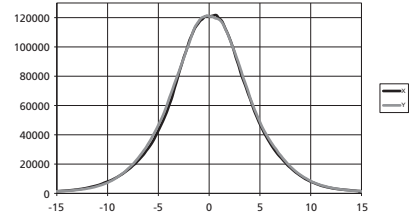

Iso-Illuminance Diagram (Flat Surface Distribution)

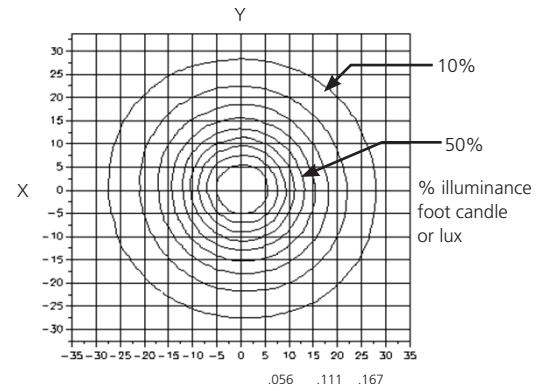

PHYSICAL

Selador D40XTI Weights and Dimensions

Total weight depends on how the individual fixture is configured.

WEIGHT*		SHIPPING WEIGHT	
lbs	kgs	lbs	kgs
15	6.8	18	8.2

\* Does not include mounting hardware

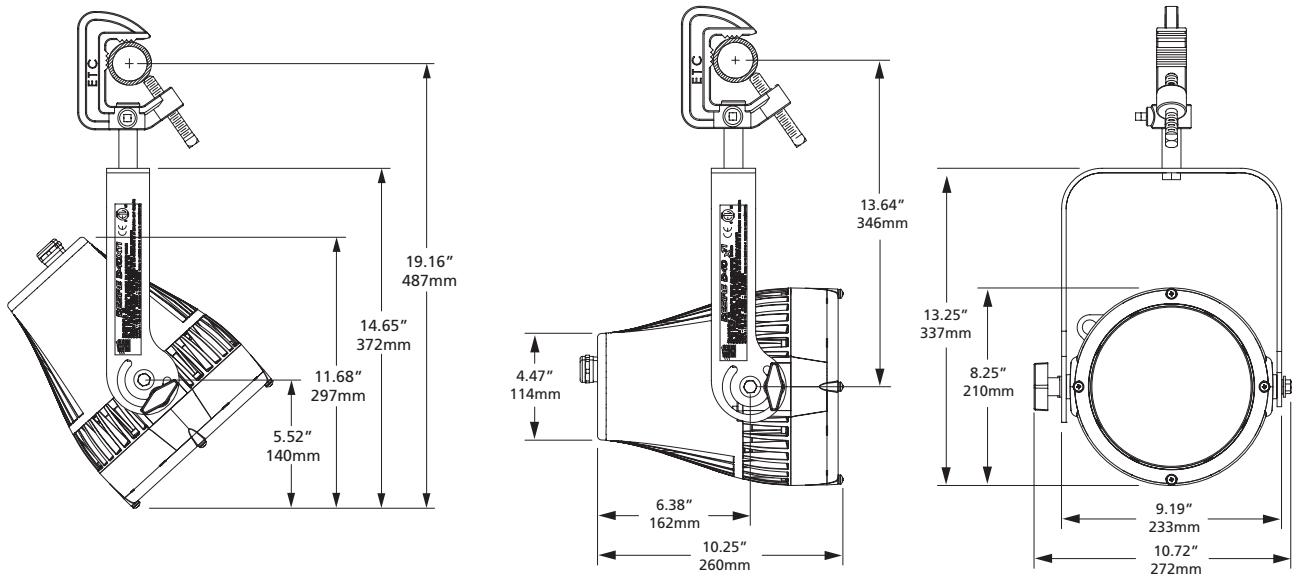

**Corporate Headquarters** • 3031 Pleasant View Rd, PO Box 620979, Middleton WI 53562 0979 USA • Tel +1 608 831 4116 • Fax +1 608 836 1736  
**London, UK** • Unit 26-28, Victoria Industrial Estate, Victoria Road, London W3 6UU, UK • Tel +44 (0)20 8896 1000 • Fax +44 (0)20 8896 2000  
**Rome, IT** • Via Pieve Torina, 48, 00156 Rome, Italy • Tel +39 (06) 32 111 683 • Fax +44 (0)20 8752 8486  
**Holzkirchen, DE** • Ohmstrasse 3, 83607 Holzkirchen, Germany • Tel +49 (80 24) 47 00-0 • Fax +49 (80 24) 47 00-3 00  
**Hong Kong** • Room 1801, 18/F, Tower 1 Phase 1, Enterprise Square, 9 Sheung Yuet Road, Kowloon Bay, Kowloon, Hong Kong • Tel +852 2799 1220 • Fax +852 2799 9325  
**Web** • www.etcconnect.com • Copyright©2013 ETC. All Rights Reserved. All product information and specifications subject to change. 7410L1011 Rev. A USA 05/13

This product is protected by one or more of the following U.S. Patents: 6,016,038, 6,150,774, 6,788,011, 6,806,659, 6,683,423 and 7,023,543