

S O U R C E F O U R[®] jr/jr Zoom

Assembly Guide

Production Dates: September 2004 - Present

ATTENTION: The part numbers listed in this guide may differ from the parts required for your particular Source Four fixture. Part numbers for fixtures change occasionally as parts are replaced or upgraded.

To ensure that you are ordering the proper part for your specific fixture, please contact your ETC dealer, or ETC Customer Service for assistance.

Table of Contents

Basic Fixture	1
Assembling basic fixture	2
Cleaning reflector	2
Lamp Socket Assembly	3
Assembling lamp socket	4
Lens Holder Assemblies	7
Assembling Fixed Field Angle Lens	8
Assembling Zoom Front Lens	8
Assembling Zoom Rear Lens	8
Cleaning lens	8
Shutter Assembly	9
Assembling Shutters	9

ETC[®], Emphasis[®], Expression[®], Insight[™], Imagine[™], Focus[™], Express[™], Unison[®], Obsession[®] II, ETCNet2[™], EDMX[™], Source Four[®], Revolution[®], Sensor[®], and WYSILink[™] are either registered trademarks or trademarks of Electronic Theatre Controls, Inc. in the United States and other countries.

All other trademarks, both marked and not marked, are the property of their respective owners.

ETC intends this document, whether printed or electronic, to be provided in its entirety.

Basic Fixture

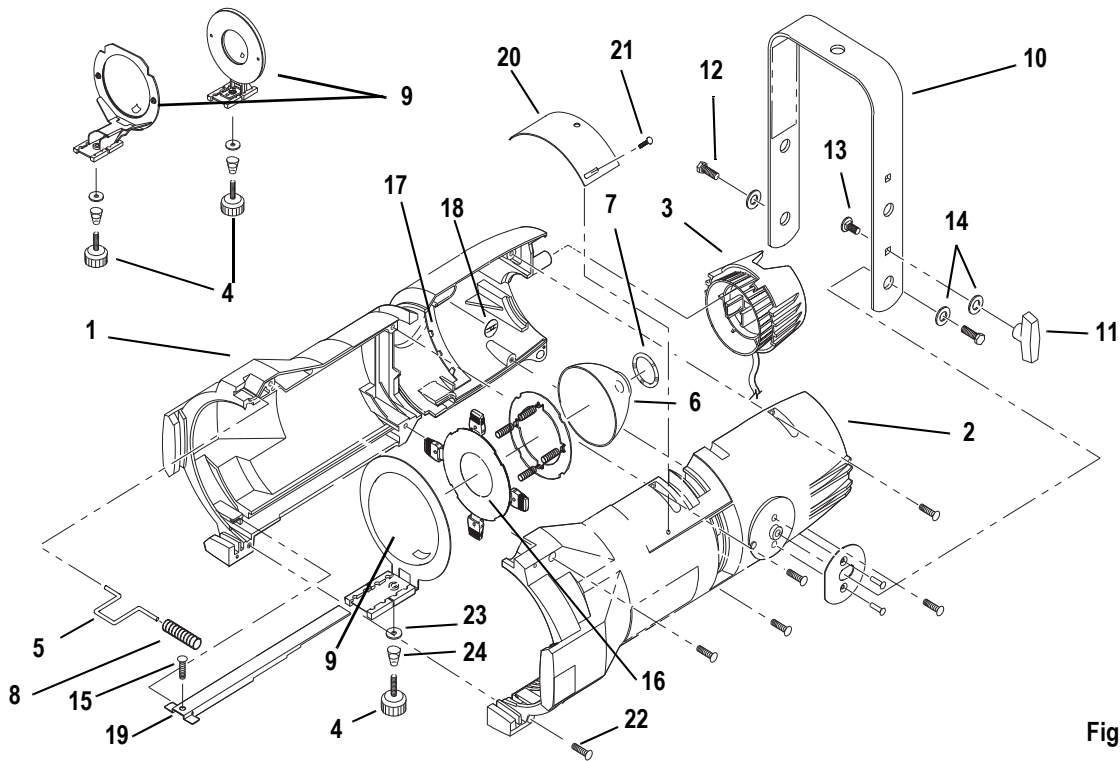

Figure 1

Reference Number	Part Number	Description	Quantity Required
1	7062A3002	Barrel, left casting, black	1
	7062A3002-1	Barrel, left casting, white	1
2	7062A3004	Barrel, right casting, black	1
	7062A3004-1	Barrel, right casting, white	1
3	7062A2008	Lamp socket assembly, black (see page 3)	1
	7062A2008-1	Lamp socket assembly, white (see page 3)	1
4	HW8201	Knob, 10-32X.50LG male stud, black	1 or 2
5	7061A3005	Retainer, gel clip	1
6	7062A4010	Reflector, jr, glass	1
7	7062A3007	Spring, round	1
8	HW750	Spring, gel retainer	1
9	See page 7	Lens Assemblies	
10	7062A3009	Yoke, jr, black	1
	7062A3009-1	Yoke, jr, white	1
11	HW8144	Handle, yoke knob, 3092, 5/16-18, female	1
12	HW5193	Bolt, hex 5/16-18 x 1.0" black oxide (yoke)	2
13	HW5125	Bolt, carriage 5/16-18	1
14	HW5126	Washer, flat, 5/16, black oxide (yoke)	3
15	HW391	Screw, PHMS, 8-32 X 3/4 LG.	1
16	See page 9	Shutter assembly	1
17	7062A3013	Spring, reflector support	2
18	HW8200	Retainer, push on	2
19	7062A3014	Light baffle strip	1
20	7062A3015	Cover, iris slot	1
21	HW372	Screw, PhPHMS, 8-32 X 1/4 black oxide	2
22	HW3165	Screw, 8-32 x 1/2 PhPH tapite	6
23	HW4117	Nylon, washer flat, #10	1 or 2
24	HW779	Spring compression	1 or 2

Assembling basic fixture

Tools Required:

- #2 Phillips screwdriver

- Step 1: See [Figure 1](#). Place the left barrel casting (1) open side up on your work surface with the colorframe end to your right.
- Step 2: If necessary, place spring (17) (see over post in right and left castings (1 and 2). Secure with clip (18).
- Step 3: Place shutter assembly (16) ([See “Assembling Shutters” on page 9.](#)) into the shutter slot in left casting (1) with the rounded side of the shutter handles facing right (gel opening end of the fixture).
- Step 4: Install the short end (without the flattened notch) of the gel retainer clip (5) in the left casting (1).
- Step 5: Position clip (5) in the forward, locked position, then install the retainer spring (8) on the clip.
- Step 6: Snap spring (7) onto reflector (6) and place assembly into left casting (1) so that the front edge of the reflector is supported by spring (17). The spring (7) on the back rests in the left casting rear supports.
- Step 7: Gently set the right barrel casting (2) onto the left casting so that the gel clip retainer, shutter assembly and reflector assembly fit into their respective positions.
- Step 8: Starting with the corner nearest the gel clip retainer (5), attach the right casting to the left casting with screws (22). Do the right screws first, then the middle screws, then the left screws. Hand tighten only (25 inch pounds).
- Step 9: Install the iris slot cover (20) onto the barrel assembly with screws (21).
- Step 10: With the colored dot on the lens facing out the barrel, slide the lens holder assembly (or assemblies, if Zoom) into the lens holder track inside the barrel. The assembly should slide smoothly in the track.
- Step 11: Insert light baffle strip (19) through front of barrel assembly and through hole in lens holder assembly. Slide strip (19) through supports in front of fixture and install screw (15), spring (24), washer (23), and knob (4).
- Step 12: Attach the lamp socket assembly (3,) ([See “Assembling lamp socket” on page 4.](#)) to the barrel assembly with the knurled head screw.
- Step 13: Attach yoke (10) to barrel assembly with bolts (12) and washers (14). Attach yoke knob (11) with bolt (13) and washer (14) to side of fixture with clutch plate.
- Step 14: Tighten bolts (12) to secure yoke to fixture. Tighten yoke knob (11) to secure yoke in desired position.

Cleaning reflector



WARNING: *Do not use ammonia-based or other harsh commercial cleaners. Clean reflector only as directed.*

Commercially available glass cleaning agents should be avoided as they may contain ammonia, other harsh chemical detergents or abrasive agents. These cleaners may damage the glass surface and the Anti-Reflective coatings. Do not immerse or soak the glass in any cleaning solution.

Remove dust with a blast of oil-free air or wipe with a clean, lint-free cloth. Isopropyl alcohol, distilled water or a 50%-50% mixture of each can be used to clean the glass surface.

Lamp Socket Assembly

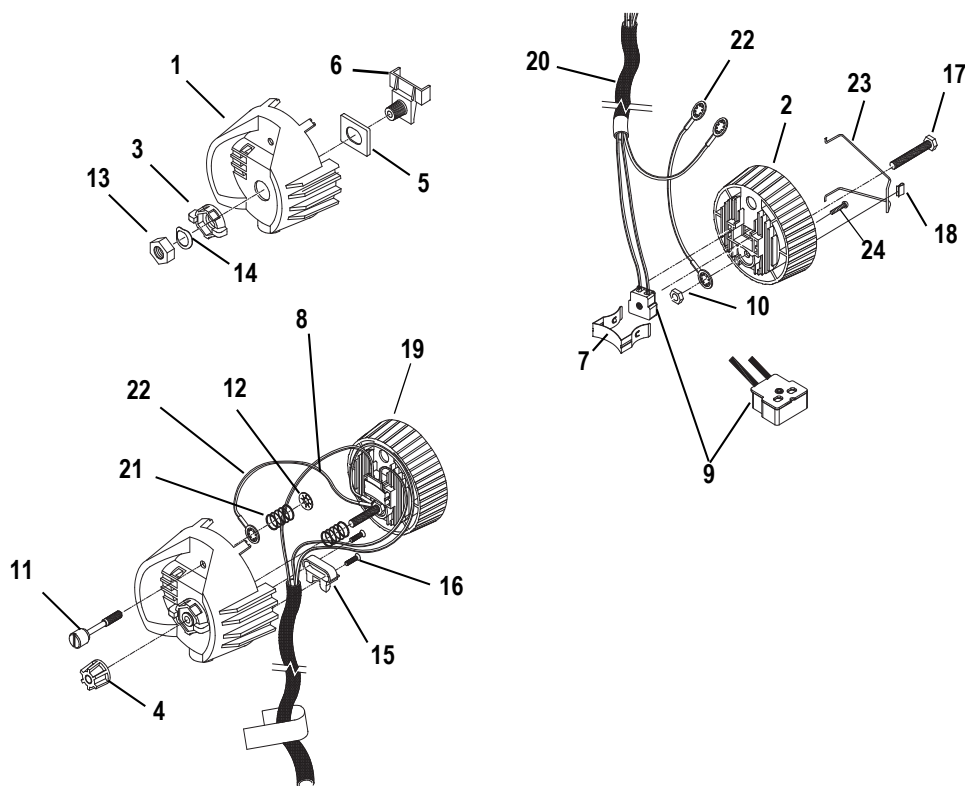

Figure 2

Reference Number	Part Number	Description	Quantity Required
1	7060A3055	Housing, socket, casting, black	1
	7060A3055-1	Housing, socket, casting, white	1
2	7060A3007	Socket, light baffle casting, raw	1
3	7060A4007	Knob, X-Y, lamp set	1
4	7060A4008-02	Knob, Z, lamp set w/female insert	1
5	7060A4011	Bushing, cup	1
6	7060A3011	Hub, index, casting	1
7	7060A3012	Spring, lamp retainer	1
8	HW748	Spring, compression	1
9	7060B7019	Complete UL socket assembly	1
10	HW534	Nut, hex, 1/4-20, black zinc	1
11	7060A3025	Screw, 1/4-20 knurled head	1
12	HW746	Retaining ring, flat, Southco	1
13	HW5123	Nut, hex, 9/16-18, black zinc	1
14	HW747	Washer, wave	1
15	7060A3056	Clamp, strain relief, painted	1
16	HW3103	Screw, 8-32 x 5/8 PhFHMS, black zinc	2
17	HW5122	Bolt, 1/4-20 x 1.75, full thread, black zinc	1
18	HW8209	Clip Tinnerman	1
19	7060B7003	48" W420 wire, 16 gauge, 200° C/300V, green UL 1180/CSA AWM with lug J490T installed	1
20	W6195	36" sleeve, fiberglass	1
21	HW749	Spring, ground	1
22	7060B7007	4" W420 wire, 16 gauge, 200° C/300V, green, UL 1180/CSA AWM with two J490T lugs installed	1
23	7060A3085	Source Four Lamp Retainer Wire	1
24	HW2125	Screw, 6-32 x 3/8, PhFHTC, Type 1, zinc	1

Assembling lamp socket

Tools Required:

- Open-end adjustable wrench or a 7/16" socket
- Needle-nose pliers
- #2 Phillips screwdriver

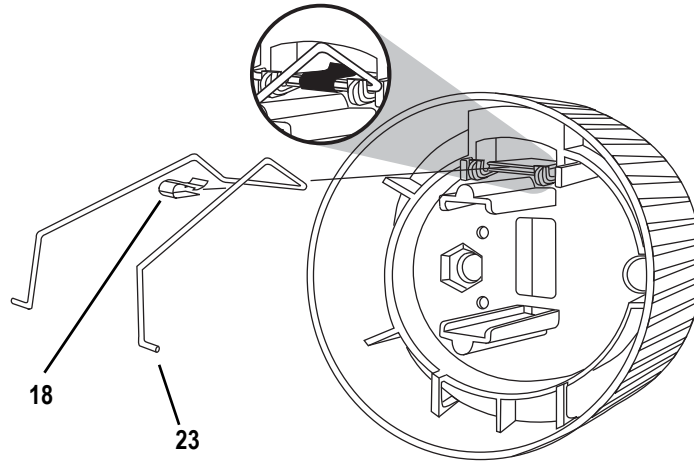

Figure 3

- Step 1: Set the crossbar of the retainer clip (25) under the two hooks on the clip bracket as shown in [Figure 3](#).
- Step 2: Place the Tinnerman clip (18) over the retainer clip crossbar between the two hooks and press it down firmly until it snaps into place.

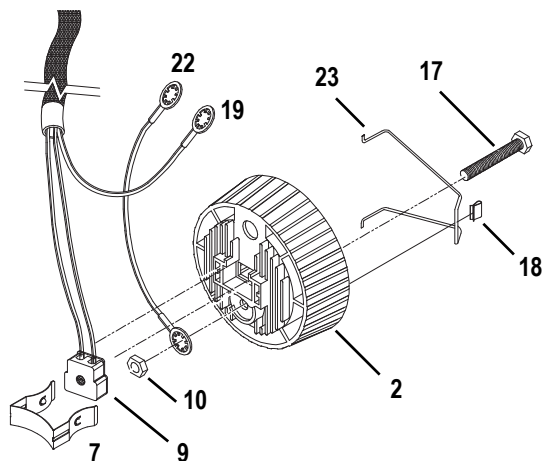

Figure 4

- Step 3: Insert the bolt (17) through the light baffle socket casting (2). See [Figure 4](#).
- Step 4: Install the green ground wire assemblies (19 and 22) on the bolt (17) with the prongs on the crimped connectors toward the casting. Run both wires through the indent in the lip around the bolt hole. Secure with nut (10) and tighten securely (60 inch pounds).
- Step 5: Place the socket assembly (9) into the light baffle socket casting (2). Be sure it is well seated.

- Step 6: Install the lamp retainer spring (7). The lamp retainer spring secures the socket. Insert the spring one end at a time, making sure the rectangular slot in each side of the spring seats on the corresponding tab in the casting.



Note:

If the spring does not seat correctly, coax it into place with a screwdriver or needle-nose pliers.

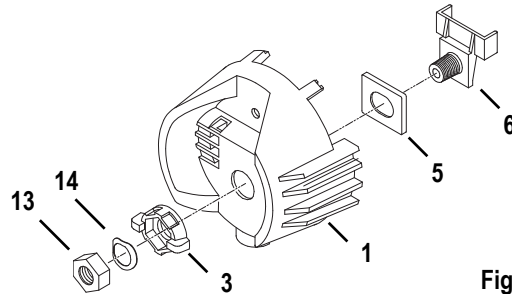

Figure 5

- Step 7: Install the bushing cup (5) into the housing socket casting (1) as shown in [Figure 5](#). The cup should slide smoothly up and down, but not side to side.
- Step 8: Insert the threaded end of the index hub (6) through the holes in the bushing cup and the back of the housing socket casting (1).
- Step 9: Slide the X-Y knob (3) over the exposed index hub bolt (6), then insert the wave washer (14) on the bolt and secure with the 9/16 hex nut (13). Hand tighten the X-Y knob (3).



Note:

Install the wave washer with the upward curve toward the hex nut.

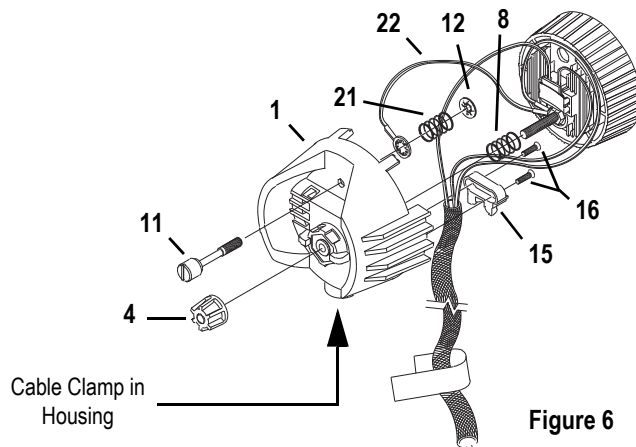

Figure 6

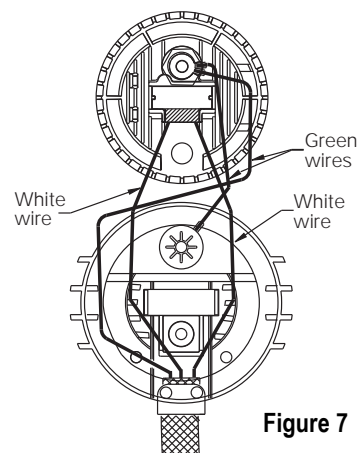

Figure 7

- Step 10: Insert the knurled head screw (11) through the housing socket casting (1) as shown in [Figure 6](#).
- Step 11: Install the shorter green ground wire (22) onto the screw. The prongs on the crimped connector should be toward the casting.
- Step 12: Install the ground spring (21) onto the screw and secure it with the Southco flat retaining ring (12). Install the Southco ring with its prongs away from the casting.



Note: Use pliers to straighten the Southco retaining ring (12) if it bends when you install it on the bolt.

Step 13: Lay the leads in the bottom half of the cable clamp (located in the housing socket casting [1]), making sure that the fiberglass sleeving extends slightly past the screw holes in the housing socket casting. Install new sleeving if necessary. Then, route the wires as shown in [Figure 7](#).



CAUTION: You must follow the wire routing diagram to ensure that the socket leads do not interfere with the lamp focus mechanism.

Step 14: Install the top half of the cable clamp (15) and secure it with the two screws (16). Tighten the screws alternately to ensure a solid connection.



Note: To ensure that the clamp holds the cable tightly, flatten the cable, then fold over the sleeving before you install the top half of the clamp. Make sure the top edge of the cable clamp is even with the edge of the socket to prevent interference with lamp focus movement. Make sure sleeving is not pinched.

Step 15: Place the compression spring (8) on the protrusion on the inside of the index hub (6).

Step 16: Insert bolt (17) through spring (8) and through the index hub (6) of the housing socket (1), joining the two castings. Make sure wires are not pinched between the two pieces.

Step 17: Before proceeding, check again to make sure the wires are still positioned as indicated in [Figure 6](#). Adjust if necessary.

Step 18: Press the two castings together firmly so the bottom of the light baffle (2) sits on top of the cable clamp (15), then install the Z lamp knob (4). Hand tighten the knob all the way to the right.



CAUTION: You must install Z knob as described above to ensure proper lamp focus travel.

Lens Holder Assemblies

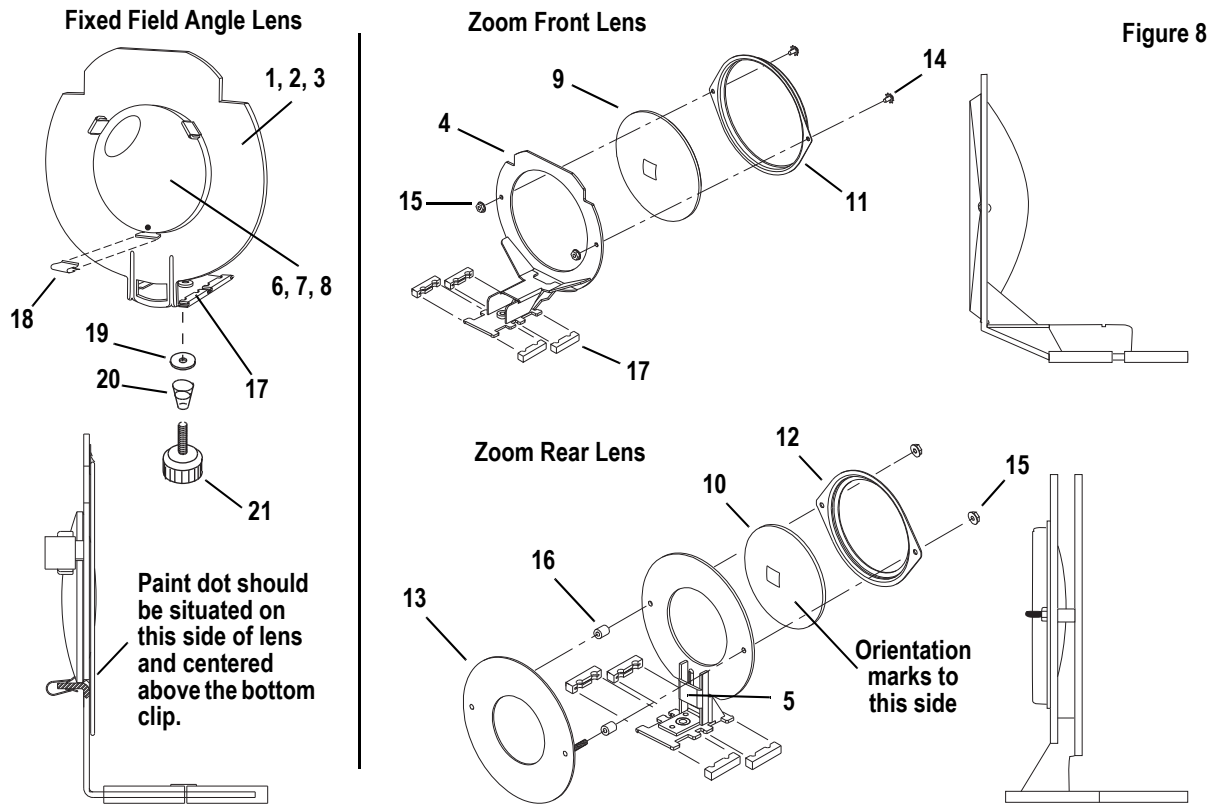

Figure 8

Reference Number	Part Number	Description	Quantity Required
1	7062A3005	Lens holder, 26°	1
2	7062A3017	Lens holder, 36°	1
3	7062A3018	Lens holder, 50°	1
4	7062A3019	Lens holder, Zoom, forward (Source Four jr. Zoom only)	1
5	7062A3020	Lens holder, Zoom, back (Source Four jr. Zoom only)	1
6	7062A4001	Lens, 26°, "black dot"	1
7	7062A4002	Lens, 36°, "white dot"	1
8	7062A4003	Lens, 50°, "yellow dot"	1
9	7062A4008	Lens, Zoom, forward (Source Four jr. Zoom only)	1
10	7062A4009	Lens, Zoom, back, black (Source Four jr. Zoom only)	1
11	7062A3027	Lens cover, Zoom, front, 25°-50° (Source Four jr. Zoom only)	1
12	7062A3026	Lens cover, Zoom, rear, 25°-50° (Source Four jr. Zoom only)	1
13	7062A3029	Plate, secondary aperture (Source Four jr. Zoom only)	1
14	HW1119	Screw 4-40 x 1/4 SPHMS, black Oxide	2
15	HW196	Nut 4-40 Keps	4
16	HW1137	Spacer (Source Four jr. Zoom only)	2
17	7060A4010	Bushing gate (fixed, front, or rear lens)	4
18	HW8209	Tinnerman clip	3
19	HW4117	Nylon washer, flat, #10	1 or 2
20	HW779	Spring, compression	1 or 2
21	HW8201	Lens knob, 10-32 x.50 LG male stud, black (Fixed or Zoom)	1 or 2
	7062A2001	Lens holder assembly, 26° (black dot)	1
	7062A2003	Lens holder assembly, 36° (white dot)	1
	7062A2004	Lens holder assembly, 50° (yellow dot)	1
	7062A2005	Lens holder assembly, Zoom, forward	1
	7062A2006	Lens holder assembly, Zoom, rear	1

Assembling Fixed Field Angle Lens

- Step 1: Place the lens (6, 7 or 8) on the lens holder (1, 2 or 3) between the tabs. The paint dot should be on the side opposite the tabs.
- Step 2: Position the lens by centering the paint dot above the bottom tab notch, as shown in [Figure 8](#). This will keep the paint dot visible after the fixture is fully assembled.
- Step 3: Center one Tinnerman clip (18) on each tab, and press clip until it is fully seated. If clips are in uneven positions, lens will be tilted or loose.
- Step 4: Firmly press the clips down and then push the spine of each clip towards the center of the lens. This will ensure that the clips contact the lens surface.
- Step 5: Check lens and make sure the clips hold it securely.
- Step 6: Snap the bushings (17) onto the lens holder assembly as shown.

Assembling Zoom Front Lens

- Step 1: Position the lens (9) between the lens holder (4) and the lens cover (11) so that the convex side of the lens faces the lens holder, as shown in [Figure 8](#).
- Step 2: Align the holes in the lens cover with the holes in the lens holder as shown.
- Step 3: Secure the lens cover and the lens to the lens holder using screws (14) and locking nuts (15). Tighten securely to ensure the lens cannot move.
- Step 4: Snap the bushings (17) onto the lens holder (4) as shown.

Assembling Zoom Rear Lens

- Step 1: Slide spacers (16) over the PEM studs of the secondary aperture plate (13), as shown in [Figure 8](#).
- Step 2: Insert the PEM studs on the secondary aperture plate (13) through the holes in the lens holder (5).
- Step 3: Position the lens (10) between the lens holder (5) and lens cover (12) as shown. The blue orientation marks on the lens should face the lens holder.
- Step 4: Insert the PEM studs of the secondary aperture plate (13) through the lens cover (12).
- Step 5: Secure the lens cover, lens, and aperture plate using nuts (15).
- Step 6: Snap the bushings (17) onto the lens holder (5) as shown.

Cleaning lens



WARNING: *Do not use ammonia-based or other harsh commercial cleaners. Clean lens only as directed.*

Commercially available glass cleaning agents should be avoided as they may contain ammonia, other harsh chemical detergents or abrasive agents. These cleaners may damage the glass surface and the Anti-Reflective coatings. Do not immerse or soak the glass in any cleaning solution.

Remove dust with a blast of oil-free air or wipe with a clean, lint-free cloth. Isopropyl alcohol, distilled water or a 50%-50% mixture of each can be used to clean the glass surface.

Shutter Assembly

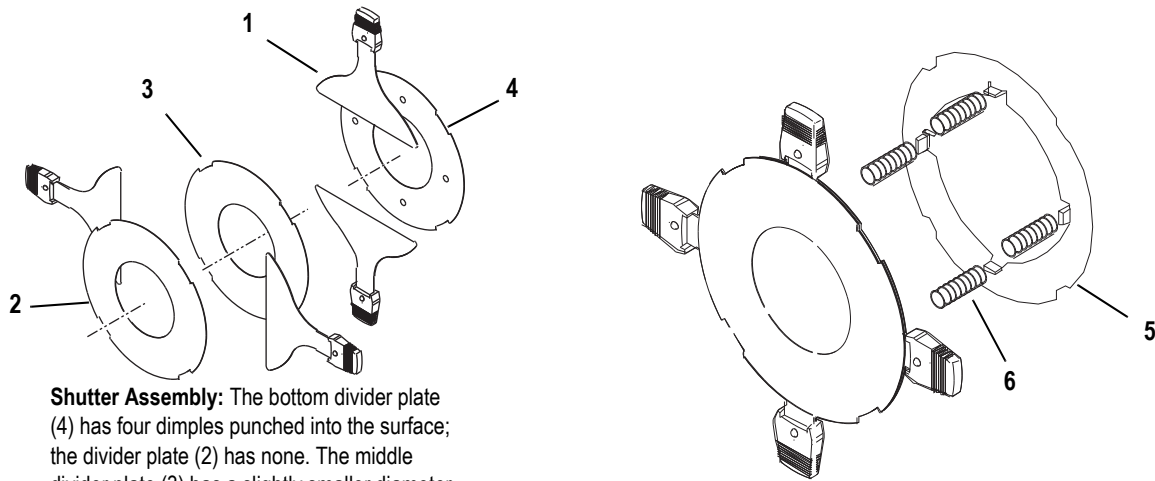

Shutter Assembly: The bottom divider plate (4) has four dimples punched into the surface; the divider plate (2) has none. The middle divider plate (3) has a slightly smaller diameter hole than the other two.

Figure 9

Reference Number	Part Number	Description	Quantity Required
1	7062A2002	Shutter blade assembly	4
2	7062A3016	Plate, divider	1
3	7062A3010	Plate, Gate, middle	1
4	7062A3030	Plate, divider with dimples	1
5	7062A3031	Plate, spring support	1
6	HW754	Spring, shutter	4

Assembling Shutters

Step 1: Place the divider plate (2) on a flat surface.



WARNING: *Divider plate edges may be sharp. Handle with caution!*

Step 2: Place two shutter blades (1) on top of plate (2). Handles should extend out past the edge of the divider plate.

Step 3: Place the middle divider plate (3) on top of the two shutter blades. The notches in the divider plates must line up.

Step 4: Place the two remaining shutter blades (1) on top of the middle divider plate.



Note: *The third and fourth shutter blade handles should be perpendicular to the previous shutter handles.*

Ensure that the rounded side of all shutter handles face the same direction.

Step 5: Place the top divider plate (4) on top of the third and fourth shutter blades. The raised dimples should point away from the shutters.

Step 6: Install the four springs (6) onto the nips on the spring support plate (5).

Step 7: Place the dimples of the plate divider (4) onto the open ends of the springs. Carefully place assembly in fixture casting ([See "Assembling basic fixture" on page 2.](#), step 3).



Corporate Headquarters ■ 3031 Pleasant View Road, P.O. Box 620979, Middleton, Wisconsin 53562-0979 USA ■ Tel +608 831 4116 ■ Fax +608 836 1736
London, UK ■ Unit 26-28, Victoria Industrial Estate, Victoria Road, London W3 6UU, UK ■ Tel +44 (0)20 8896 1000 ■ Fax +44 (0)20 8896 2000
Rome, IT ■ Via Ennio Quirino Visconti, 11, 00193 Rome, Italy ■ Tel +39 (06) 32 111 683 ■ Fax +39 (06) 32 656 990
Holzkirchen, DE ■ Ohmstrasse 3, 83607 Holzkirchen, Germany ■ Tel +49 (80 24) 47 00-0 ■ Fax +49 (80 24) 47 00-3 00
Hong Kong ■ Rm 1801, 18/F, Tower 1 Phase 1, Enterprise Square, 9 Sheung Yuet Road, Kowloon Bay, Kowloon, Hong Kong ■ Tel +852 2799 1220 ■ Fax +852 2799 9325
Service: (Americas) service@etcconnect.com ■ (UK) service@etc europe.com ■ (DE) techserv-hoki@etcconnect.com ■ (Asia) service@etcasia.com
Web: www.etcconnect.com ■ Copyright © 2007 ETC. All Rights Reserved. ■ Product information and specifications subject to change.
7062M2500-06.01 ■ Rev A ■ Released 08/2007