



CMK4 CMK5

CloseMic™ Kit

User's Guide

Congratulations on your purchase of the Earthworks® CMK4 or CMK5 kit of DM20 DrumMic™ Tom & Snare Microphones. When using these microphones on your toms and snare, you will hear more detail in the attack in addition to hearing subtle details that cannot be heard when using conventional microphones. You will walk into a whole new world of pristine drum sound using the DM20 DrumMic™ High Definition Microphones™. After reading this manual, if you have any unanswered questions, please email or phone us using the contact information on the back cover of this manual.

First, identify all the items that came in your CMK4 or CMK5 kit to verify that you have received everything listed below.

CMK4 CloseMic™ Kit

- 4 – DM20s for Toms & Snare
- 4 – RM1 RimMount™ for DM20s
- 4 – PW1 Foam Windscreens
- 1 – High Impact Carrying Case with custom foam insert
- 1 – Users Manual

CMK5 CloseMic™ Kit

- 5 – DM20s for Toms & Snare
- 5 – RM1 RimMount™ for DM20s
- 5 – PW1 Foam Windscreens
- 1 – High Impact Carrying Case with custom foam insert
- 1 – Users Manual

IMPORTANT NOTICE - Please Read This

The DM20's High SPL Handling and Lower Output Level

The DM20 has been designed for close miking toms and snares with high SPL handling of 150dB and a reduced output level. In most cases the DM20 will not require the use of a pad to prevent overloading the input of outboard microphone preamps, or the mic preamp inputs on mixers, consoles or computer audio interfaces. The majority of these units will accommodate high microphone levels at the preamp input without distortion. However, the more sensitive units will not handle high mic levels at the preamp input will require the use of a pad to prevent the preamp from distorting. We encourage you to check the specifications of your preamp, mixer, console or computer audio interface to verify that the microphone preamp input will accommodate high levels of approximately +20dBV.

Different Types of Preamp Input Pads

Some outboard preamplifiers, mixers or consoles may have a built-in mic preamp pad that can be switched in or out. However, on some models these pads are not attenuators that precede the preamplifier input and just reduce the gain of the preamplifier itself. Unless these preamplifiers will handle a high input level (i.e.

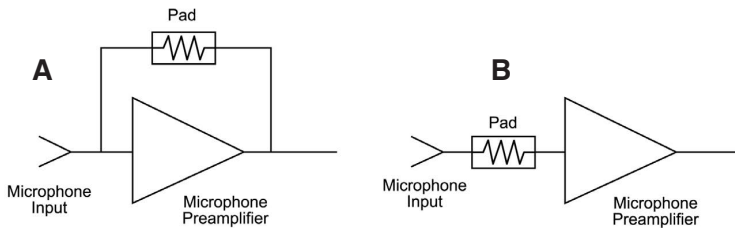

This so-called pad, is not really a pad, it only changes the gain of the preamp, and may not prevent overload of the preamp input.

This is an actual microphone preamp pad, which is an attenuator that will reduce level prior to the preamp input.

Figure 1-A and 1-B Types of Preamp Input Pads

+20dBV) these so-called pads will typically provide no preamp input overload protection from microphones with high output levels (see Fig. 1-A). Some out-board preamps, mixers, consoles or computer audio interfaces have actual pads that precede the preamplifier input. These types of pads will provide preamp input overload protection that is needed (see Fig. 1-B). Such pads will typically provide -10dB or -20dB attenuation. If an external XLR type mic pad is needed, Earthworks offers a LevelPad™ which provides -20dB of attenuation and is simply plugged into the microphone cable. The DM20's lower output level, in most cases, should not require an external pad when close-miking toms or snares.

Earthworks Drum Mics

The Earthworks DrumKit™ High Definition Three-Microphone Systems™ have had great success because they pick up drum sounds with far more detail and accuracy than conventional microphones. This improved sound quality is due to Earthworks® advanced proprietary technologies.

Many drummers such as Jeff Campitelli with Joe Satriani, Steve Gadd, Keith Carlock, Ronnie Vannucci, Anton Fig, Anthony King and many top FOH engineers touring with major artists are using Earthworks High Definition Drum Microphones™ for overheads, toms, snare and kick drum with exceptional results.

The DM20 is a new generation of Earthworks tom and snare microphones. It features a stable gooseneck for easy positioning that will stay in place even when the drums are played very hard. It also can handle high acoustic sound levels up to 150dB SPL. The Earthworks proprietary polar technology provides a stunning amount of rear rejection and a frequency response out to 80 degrees off-axis within 3dB of the on-axis response. This vastly reduces phase cancellations, minimizes the pickup of unwanted sounds at the rear of the microphone and provides significantly more gain before feedback for live sound applications.

Earthworks High Definition Microphones™ the New Science in Microphones

David Blackmer, the brilliant engineer who invented the innovative technologies of dbx, is also the inventor and founder of Earthworks. In the last few years of his life, David developed a number of revolutionary technologies that dramatically improve the sound quality and performance of microphones. In short, Earthworks High Definition Microphones™ pick up sounds more accurately and with more detail than conventional microphones. These dramatic improvements are in the areas of impulse response, diaphragm settling time and advanced polar technologies. Those who have heard Earthworks High Definition Microphones™ say they have more rear rejection and more gain before feedback in addition to hearing more detail of the attack, more subtle detail from low level signals thereby providing a more pristine sound quality than with any conventional microphones can provide, regardless of price.

Miking Drums

There are many ways to mic drums and it seems that most every recording or live sound engineer has their own way of doing this. Our objective is not to indicate which drum miking approach is better, but to make suggestions and look at advantages and disadvantages of each. Every engineer or producer uses their own methods to obtain the results they desire, and that's what matters.

Multi-microphone Method

The objective in multi-microphone drum miking is to place a separate microphone on most or all the elements of a drum set. Typically, separate mics are used on snare, toms, hi-hat and kick drum, along with one or two overhead microphones. The overhead mics pick up the overall sound of the drum set including cymbals (which are typically not miked separately). By this method, the mixing engineer can control the level, and signal processing (limiting, EQ, etc.) for each element of the drum set (toms, snare, hi-hat, etc.). This provides a great deal of control over the sound of the entire drum set and allows bringing out certain patterns on hi-hat, snare, etc. Multi-miked drums are desirable for live sound, providing more control and increased gain before feedback, and when recording in a large room with high ambient sound this reduces the amount of unwanted room sound and provides greater control of the drum mix.

Earthworks Near-Perfect Polar Response

One of Earthwork's proprietary technologies is near-perfect polar response i.e. very uniform response over the front 160° of the microphone. Conventional microphones (even expensive ones) have a loss of high frequencies at the sides of the microphone. Have you ever tried to put three singers on a single

directional microphone? The singer at the front of the mic sounds great, but the two on the sides of the microphone sound muffled due to the lack of high frequency pickup at the sides of the microphone. In contrast, the Earthworks proprietary polar technology provides virtually the same frequency response on the sides of the microphone as at the front with no more than a 3dB loss at any specified frequency out to 80° off-axis). This extremely uniform frequency response at the front and sides of the microphone dramatically reduces phasing issues when using Earthworks microphones. Refer to Figure 2 A & B to see how uniform the Earthworks microphone (A) polar response is, in comparison to the conventional microphone (B).

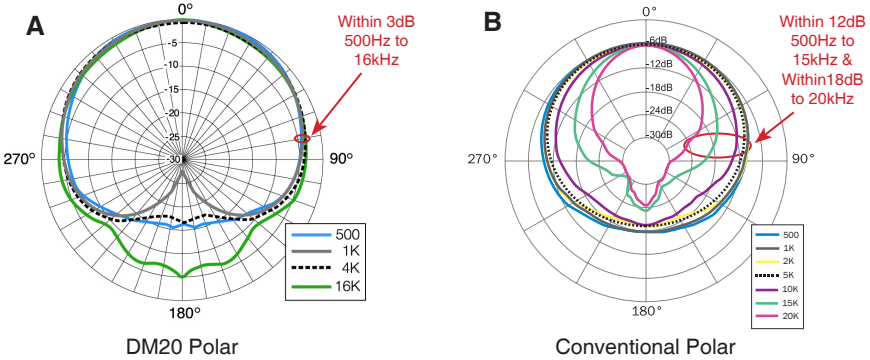

Figure 2-A & 2-B Earthworks vs. Conventional Polar Response

Nearly Twice the Amount of Rear Rejection

Another disadvantage of the multi-microphone approach is picking up the unwanted sound of other elements of the drum set from the rear of each microphone. Earthworks cardioid microphones have a very high rejection of sounds at the rear of the microphone. This greatly reduces the leakage of cymbals or other drum sounds at the rear of Earthworks microphones. Conventional microphones provide only 18dB of rear rejection, while Earthworks microphones with 32dB of rear rejection provide nearly twice the amount of rejection of conventional microphones. The Earthworks drum mics will nearly eliminate any leakage present at the rear of the microphone. Figure 3 shows conventional drum microphones with 18dB of rear rejection and Figure 4 shows the Earthworks drum microphones with 32dB of rear rejection.

**Competitive
Microphones
Approx 18dB
Rear Rejection**

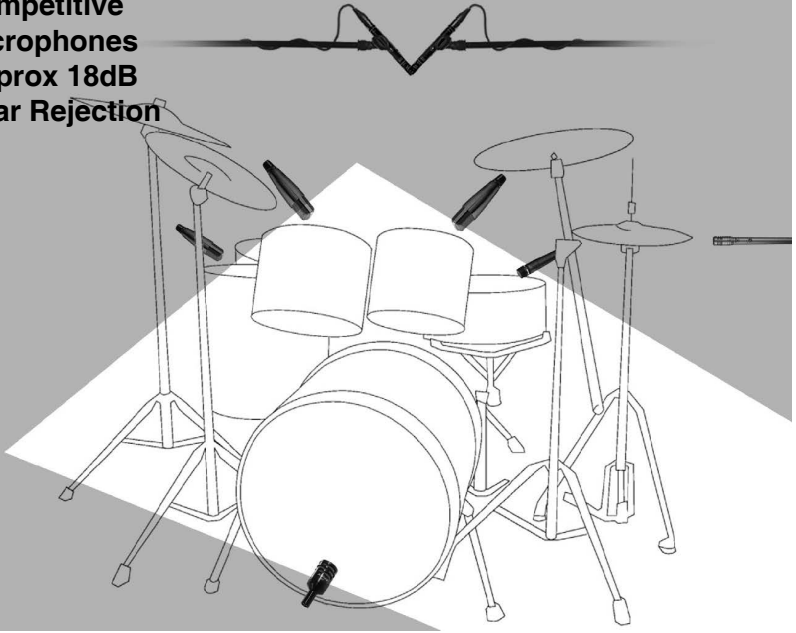

Figure 3 18dB of Rear Rejection Using Conventional Drum Mics

**Earthworks
Microphones
Approx 32dB
Rear Rejection**

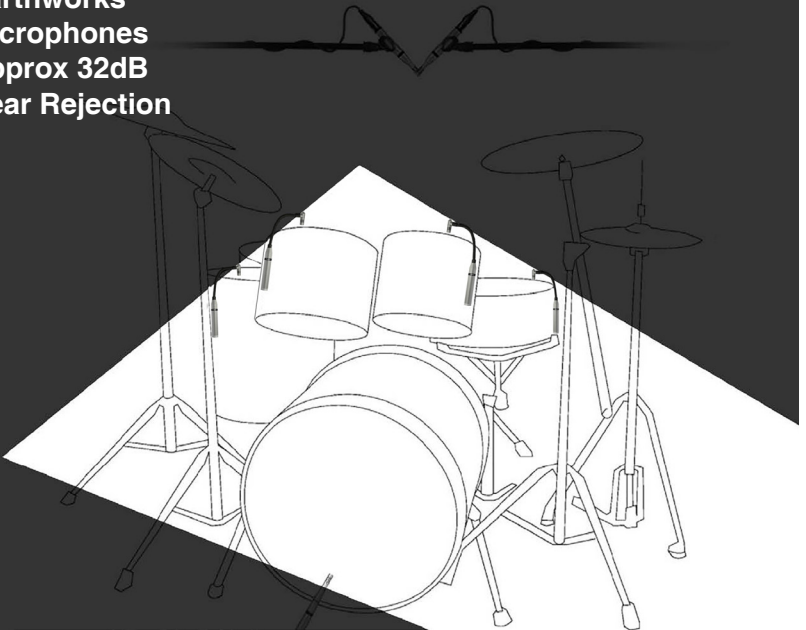

Figure 4 32dB of Rear Rejection Using Earthworks Drum Mics

Close Miking Toms and Snares with the DM20 DrumMic™ Microphones

Inserting the DM20 Microphone into the RM1 RimMount

The RM1 is designed specifically for the DM20 allowing you to mount the microphone on the side of a tom or snare. The RM1 can also be used on the top or bottom of a tom or snare.

It is suggested that you insert the DM20 microphone into the RM1 RimMount™ prior to attaching the RimMount™ to the drum.

To insert the DM20 microphone into the RM1 just place the mic head and the gooseneck into the rubber holder from the bottom of the RimMount™. Push on the body of the microphone from the bottom (XLR connector end) to move the microphone up inside the rubber holder. The fit will be firm, so you will need to apply a little pressure to move the microphone body up into the rubber holder. The suggested procedure is shown in Figure 5.

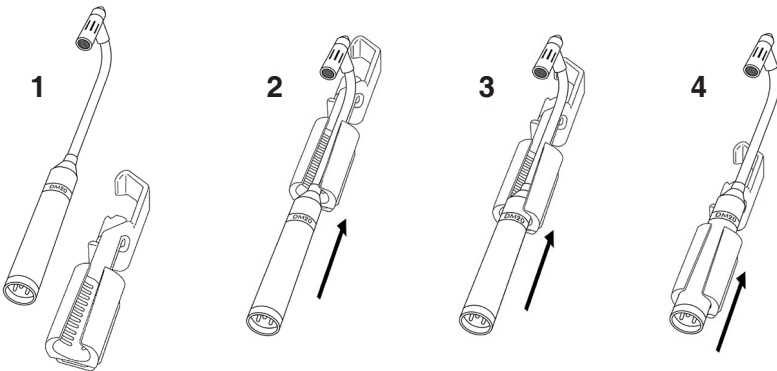

Figure 5 Inserting the DM20 DrumMic™ into the RimMount™

Mounting the RM1 RimMount™ to the Drum

The RM1 RimMount™ is designed for metal drum rims, and will not work on wooden drum rims. Attaching the RimMount to the drum rim is quite easy. While reading this section, please refer to Figure 6-A, which shows the various elements of the RimMount™. First, loosen the thumbscrew so there is more than enough space for the Delrin® cushioned rim-guide to clear the bottom of the drum rim. Then determine where on the drum rim you want to position the microphone and place the top “hook portion” of the RimMount bracket over the desired place on the drum rim.

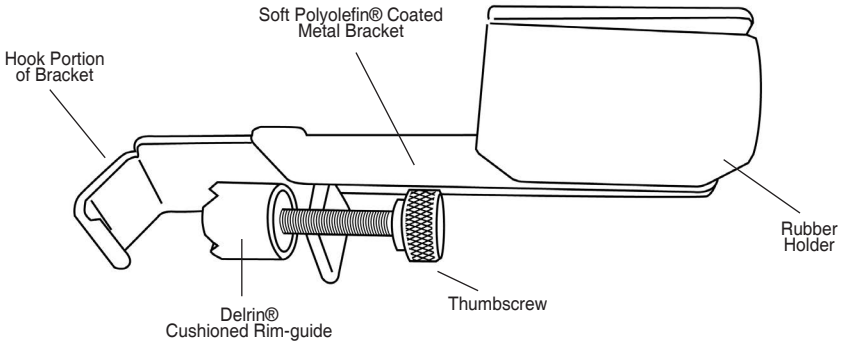

Figure 6-A. Elements of the RM1 RimMount™

Referring to Figure 6-B, notice that on the Delrin® cushioned rim-guide there are two sets of grooves. One groove is in the “center” of the rim-guide (1), while the other groove (2 & 3) is “off center” (or closer to the edge of the rim-guide). These two sets of grooves provide you with “three” mounting options: (A) using the “off center” rim-guide groove will place it closest to the drum shell, (B) or rotating the “off center” groove 180 degrees will place the rim-guide furthest away from the drum shell, and (C) the “center” groove will allow placement in-between the positions (A) and (B).

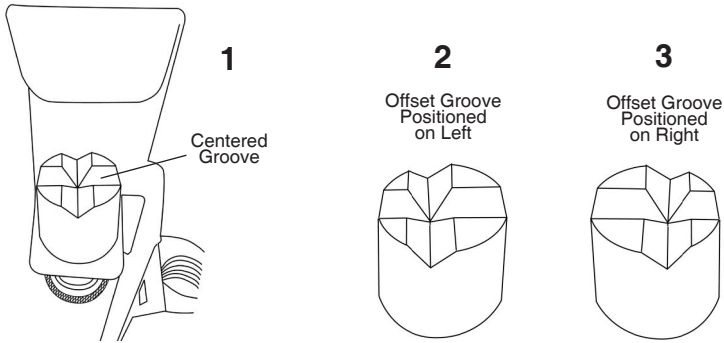

Figure 6-B Positioning the Cushioned Rim-guide

Various types of metal drum rims have the bottom flange of the rim either closer or further from the drum shell. One of the three positions (A, B or C previously mentioned) will allow the RimMount™ bracket to be mounted parallel to the drum shell. Position the rim-guide so the bottom edge “flange” of the drum rim fits comfortably into one of the RM-1 rim-guide grooves. This will ensure that the cushioned rim-guide remains securely in place as you tighten the thumbscrew to firmly secure the RM-1 to the drum rim. The soft protective Polyolefin® coating on the RimMount™ bracket will prevent the possibility of scratching the drum shell finish.

Adjusting the Microphone Height

Once the RimMount™ is mounted securely on the drum rim with the DM20 microphone housed in the rubber holder, the microphone body can be moved either up or down in the rubber holder to provide the desired height. Then the gooseneck will provide a good amount of latitude in positioning the microphone head from any microphone body height. Adjusting the height of the DM20 microphone body is indicated in Figure 7-A and 7-B.

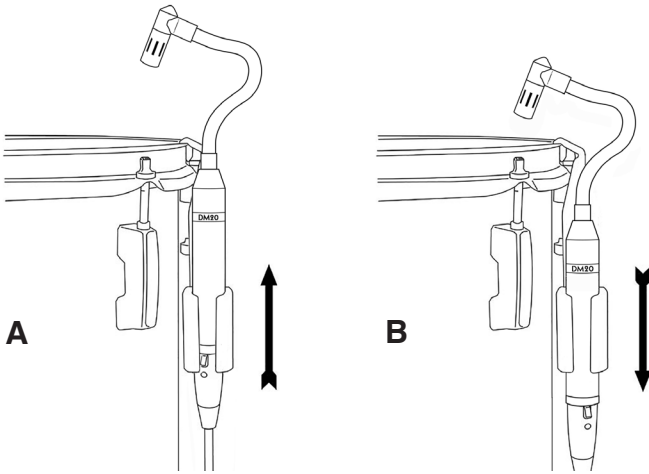
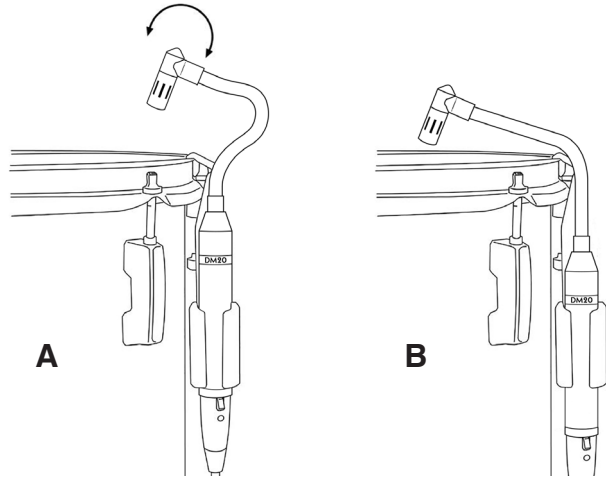

Figure 7-A and 7-B Adjusting the DM20 Microphone Height

Positioning the Microphone Head

Once the DM20 microphone height has been set, you can position the microphone head. It is suggested that the microphone head be positioned between 1.5 inches and 3 inches above the drumhead. The flexible gooseneck will allow you to move the microphone head either up or down above the drumhead as well as in and out from the drum rim. You can also change the angle of the microphone head as shown in Figure 8-A. Figure 8-B shows how the microphone head can be aimed more toward the center of the drum head by changing the position of the gooseneck. Keep in mind that the microphone head should never be placed “parallel” to the drumhead, but should always be at “an angle” to the drumhead. This will prevent the microphone diaphragm being forced to its backplate which could cause an unwanted pop or thump in the live sound or recording system.

*Figure 8-A & 8-B
Positioning the
Microphone Head*



The High Acoustic Sound Levels of Close Miked Drums

In close miking drums, one should keep in mind that the acoustic sound level at the microphone head is extremely high. Microphones used for close miking drums should be able to handle at least 140dB SPL in order to prevent audible distortion. The DM20 DrumMic™ handles up to 150dB SPL. With these high sound pressure levels, the DM20 microphone output level may be as much as +15dBV which can overload some types of microphone preamplifier inputs. Inserting the Earthworks XLR type LP20 LevelPad™ into the microphone cable will provide -20dB of attenuation to help prevent any distortion or overload. For full information refer to pages 1 and 2 of this manual.

Close Miking Snare Drums with the DM20

The DM20 has been optimized for miking toms and snare. With its frequency response of 50Hz to 20kHz, it will provide a full and fat sound from your toms and a nice crisp sound from your snare. If you feel that there is still too much low frequency response when miking a snare, use either a high-pass filter set somewhere between 60Hz and 100Hz or a low frequency equalizer (EQ) to attenuate (i.e. cut) a few dB in the area of 60Hz to 100Hz for the desired results.

The DM20 can be used on either the top drumhead, bottom drumhead or both. Figure 9-A shows the DM20 placed over the top drumhead of a snare, while Figure 9-B shows a snare drum with both the top and bottom heads miked.

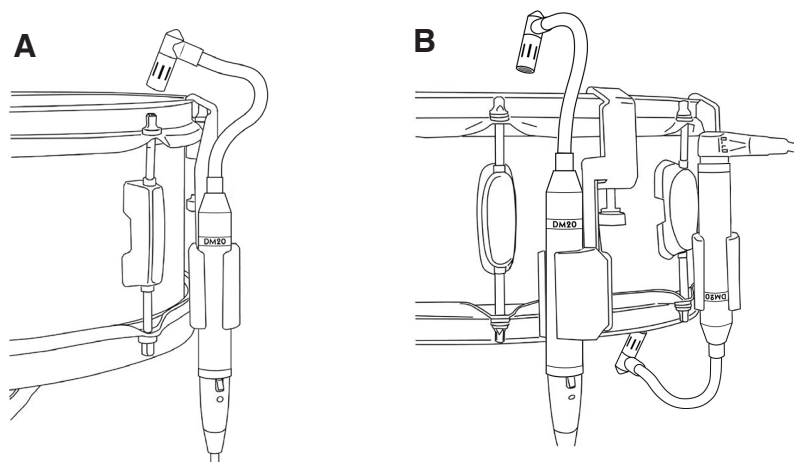

Figure 9-A and 9-B Miking the Top or Top & Bottom of a Snare

Close Miking Toms with the DM20

The extended low frequency response of the DM20 DrumMic™ will provide a rich and full tom sound. You can mike either the top or bottom head of a tom with the DM20 as indicated in Figure 10 A or B, or you can mike both the bottom and top drumheads in a similar fashion as shown on a snare in Figure 9-B.

You will notice in Figure 10-A the microphone head is placed closer to the drum rim, while in Figure 10-B the microphone head is aimed toward the center of the drumhead by changing the position of the gooseneck. Experiment with the microphone head placement as the sound or tone can change with various placements.

Earthworks High Definition Microphones™ are widely used successfully by drummers with major artists in both recording sessions and for live performance. The DM20 is designed to withstand the rigors of the road and will provide you with many years of exceptional and reliable results. We know that when you use the Earthworks DM20 DrumMics™ for your recording and live performances you will be thrilled with the results.

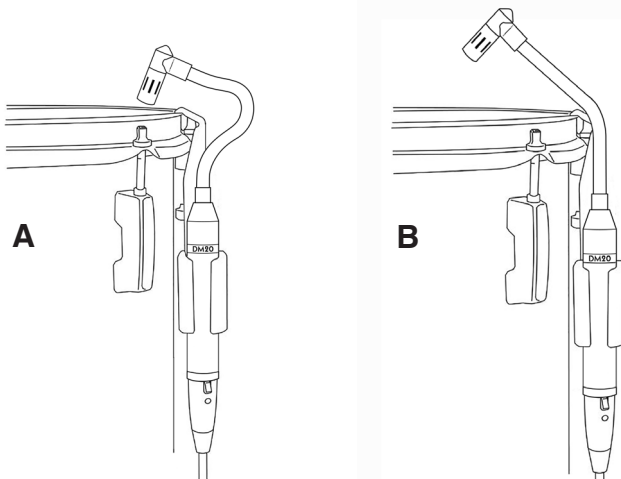

Figure 10-A and 10-B Miking the Top Head of a Tom

We are pleased to welcome you to our ever-growing family of drummers and sound engineers using Earthworks High Definition Microphones™ for recording and live sound.

We hope the suggestions in this manual have been beneficial to you. Don't be afraid to experiment with mic placement. You can be as creative with your microphone placement as you are with your music. You are the judge of what works best and sounds best.

If you have any questions, or require any additional information, feel free to contact Earthworks directly using the contact information on the back cover of this manual and don't forget to register your warranty information on the Earthworks website, (see information below).

EARTHWORKS WARRANTY

All Earthworks® products carry a limited warranty (parts and labor). Please register your warranty at www.earthworksaudio.com/register
If you have any problems with your Earthworks products, please contact our warranty/repair department by email at returns@earthworksaudio.com or by telephone at (603) 654-2433, ext 119.

NOTES:



DM20
with RM1 RimMount™

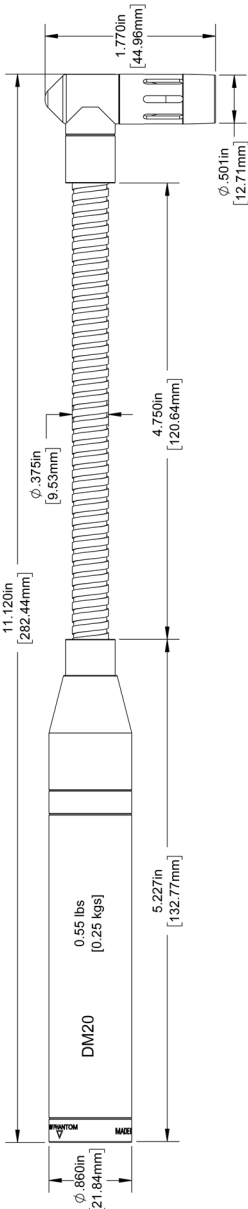

DM20 DrumMic™ for Toms & Snare

Frequency response	50Hz to 20kHz ±2dB @ 6" (15cm)
Polar Pattern	Cardioid
Sensitivity	8mV/Pa (-42dBV/Pa)
Power requirements	24-48V Phantom @ 10mA
Peak acoustic input	150dB SPL
Signal-to-Noise Ratio	74dB A-weighted
Output	XLR (PIN 2+)
Output Impedance	200Ω bal. (between pins 2&3)
Minimum output load	1,000Ω, balanced between pins 2&3
Noise	20dB (A-weighted)
Dimensions L & D	11.12 inches (282.44mm) .860 inches (22mm)
Gooseneck L & D	Length 4.75 inches (120.65mm) Diameter .375 inches (9.53mm)
Weight	.55lb (.25kg)

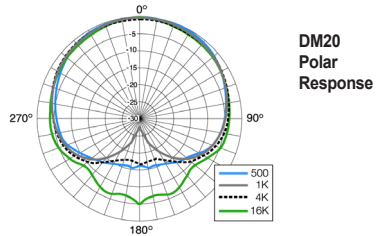

Earthworks®
HIGH DEFINITION MICROPHONES™

Made in U.S.A.

Earthworks, Inc. • 37 Wilton Rd. • Milford, NH 03055
603-654-2433 • www.earthworksaudio.com
email: sales@earthworksaudio.com • Printed in U.S.A.