

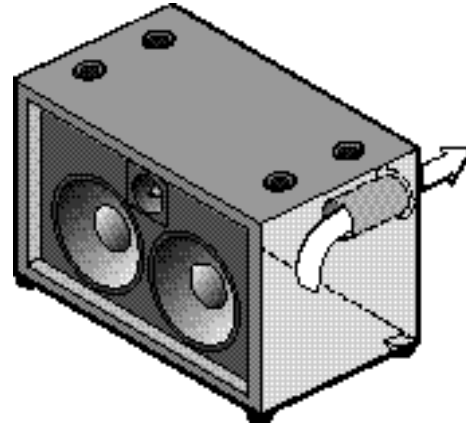

CLASSIC SERIES BASS ENCLOSURES:

SVT-210HE

Component 1: Size	2-10" Cast
Voice Coil	2"
Magnet Weight	30 oz
Component 2: Size	Horn/Driver
Voice Coil	1"
Magnet Weight	8 oz
RMS Handling	200 watts
Program Handling	400 watts
Frequency Response (-3dB)	50 - 18kHz
Useable Low Frequency (-10dB)	35 Hz
Nominal Impedance	8 ohms
Sensitivity	97 dB
Maximum SPL	119 dB
Crossover Frequency	4kHz
Dimensions	24"x18"x16"
Weight	60 lbs



SVT-15E

Component Size	1-15" Cast
Voice Coil	2.5"
Magnet Weight	80 oz
RMS Handling	200 watts
Program Handling	400 watts
Frequency Response (-3dB)	50Hz - 3kHz
Useable Low Frequency (-10dB)	33 Hz
Nominal Impedance	8 ohms
Sensitivity	98 dB
Maximum SPL	123 dB
Crossover Frequency	n/a
Dimensions	24"x22"x16"
Weight	72 lbs

