

SS-VTR Series

HEAVY-DUTY SLIDING SHELF

versatile, heavy-duty sliding shelf has a removable face option and accommodates permanent and rental equipment in mobile and fixed applications

FEATURES:

- 23-1/2" usable depth with foot holes to secure a range of Video Tape Recorder sizes
- Comes with mounting ears pre-assembled for quick installation
- Full extension lockout shelf allows for easy maintenance of your components right on the shelf
- Allows access to cable, wiring and connections from the front of the enclosure
- Optional lightweight, removable cover
- Durable black finish
- Lightweight steel construction
- 75 lb. load capacity evenly distributed at full extension



SS4-23VTR shown with SS-VTR-CVR4 removable cover panel

SPECIFICATIONS:

19" Rackmount Heavy Duty Sliding Shelf shall be Middle Atlantic Products model # SS_-23VTR (refer to chart). SS-VTR Sliding Shelf shall offer an extension of 23.5". SS-VTR Sliding Shelf shall offer a useable mounting area of 15.9" W x 23"D. SS-VTR Sliding Shelf shall have 4 foot holes for securing VTRs and other heavy components. SS-VTR Sliding Shelf shall be _ spaces (refer to chart), and accept removable cover, model # SS-VTR-CVR_(refer to chart). SS-VTR Sliding Shelf shall be 4 point mount and accommodate front to rear rackrail mounting range of 12.5" to 29". SS-VTR Sliding Shelf shall be vented. SS-VTR Sliding Shelf shall have a 75 lb. weight capacity. SS-VTR Sliding Shelf shall be finished in a durable black powder coat. SS-VTR Sliding Shelf shall comply with the requirements of be RoHS EU Directive 2011/65/EU. SS-VTR Sliding Shelf shall be manufactured by an ISO 9001 and ISO 14001 registered company. SS-VTR Sliding Shelf shall be warranted to be free from defects in material or workmanship under normal use and conditions for a period of 3 years the lifetime of the product.

Customizable specification clips available at middleatlantic.com

EIA/TIA COMPLIANT



WHAT GREAT SYSTEMS ARE BUILT ON.™

A brand of Legrand

Middle Atlantic Products
middleatlantic.com | middleatlantic.ca

96-01184 / rev b / 9-6-17

SS-VTR Series

BASIC DIMENSIONS

All dimensions in inches unless otherwise noted [bracketed dimensions are in millimeters unless otherwise noted]

TOP VIEW
(SHELF NOT EXTENDED)

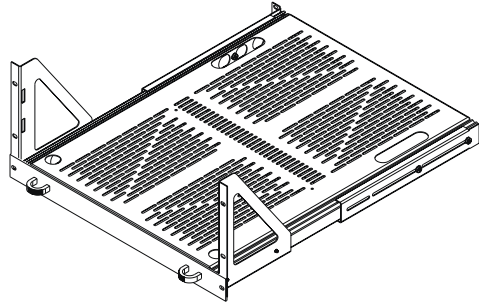
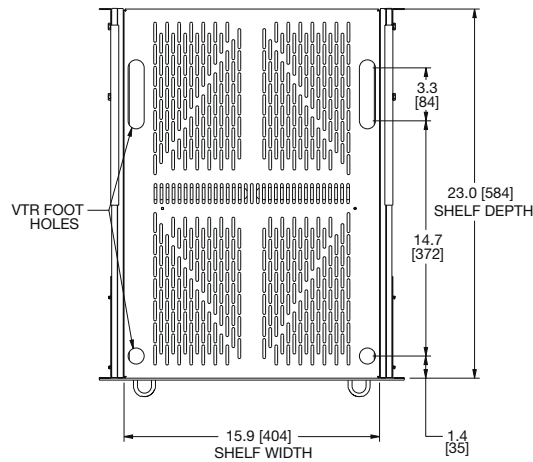

WEIGHT CAPACITY: 75LBS

SIDE VIEW
FULLY EXTENDED

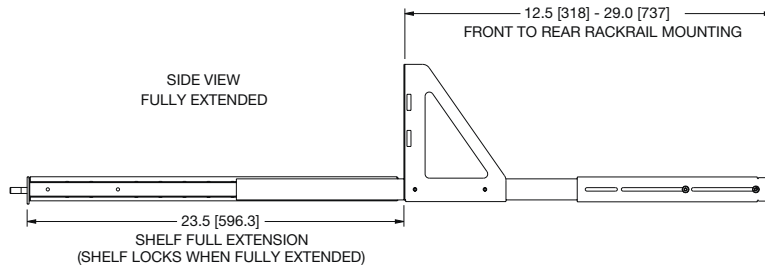

FRONT VIEW W/OPTIONAL
REMOVABLE COVER

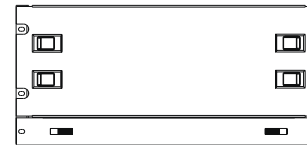

FRONT VIEW



Part #	A	B	Removable Cover
SS4-23VTR	8.71 [222] 5 SPACE	7.00 [178]	SS-VTR-CVR4
SS5-23VTR	10.46 [267] 6 SPACE	8.75 [222]	SS-VTR-CVR5

WHAT GREAT SYSTEMS ARE BUILT ON.™

A brand of legrand

Middle Atlantic Products
middleatlantic.com | middleatlantic.ca