

FUJINON

FUJINON CINE LENSES

FUJIFILM FUJIFILM Corporation

Optical Device & Electronic Imaging Products Div.
http://www.fujifilm.com/products/optical_devices/tv_cine/cine/



The included user's manual describes how to properly handle and use this product.

Important To ensure safe use and avoid risk of personal injury, please read and follow the instructions carefully.

- Product specifications, appearance, price, etc., are subject to change without prior notice.
- Product color reproduced in this brochure may differ from that of the actual product due to variations in shooting conditions and in the printing process.
- All screen images appearing in this brochure are simulated.

<https://fujinoncinelens.com>

History of FUJINON Cine Lenses



Fujifilm has been developing FUJINON Cine Lenses since 2002. We are not only making excellent use of our optical, mechanical, and electronic knowledge which have been cultivated in the broadcast lens field, but we also have enhanced those technologies to achieve superb Cine Lenses. FUJINON Cine Lenses allow cinematographers to explore the possibility of creating new images around the world that represent the broad range of human emotions.

Award

In 2017, Fujifilm received an Engineering Emmy® Award from the Academy of Television Arts & Sciences for the development of cine zoom lenses.

In developing zoom lenses that display unparalleled imaging capabilities, Fujifilm's advanced optical technologies have been recognized in the movie, television, and CM production fields around the world. The Emmy Award recognizes Fujifilm's contribution to higher image quality and further advancements in video image rendering. Going forward, Fujifilm will develop and provide new state-of-the-art products based on our proprietary technologies to respond to a diverse range of needs.



FUJINON Cine Lenses Technology

Unparalleled optical performance achieved by combining Fujifilm technologies

FUJINON Cine Lenses are developed to cover the "Super 35mm" image sensor that is used today in almost all current digital cinema cameras.

4K and Higher Compatible Optical Performance Lenses for Cinema Production

Special low dispersion glass, as well as high refractive index glass, are arranged to achieve the best optimal balance. The zoom mechanism suppresses aberrations from the WIDE side to the TELE end by adopting our exclusive floating method. These lenses feature a special HT-EBC multi layer coating technology to reduce flare and ghosts improving image quality. In addition, the contrast performance is rich with a superb 4K and higher compatible resolution. The net result is a lens series with excellent overall balance.



Aspherical lens image

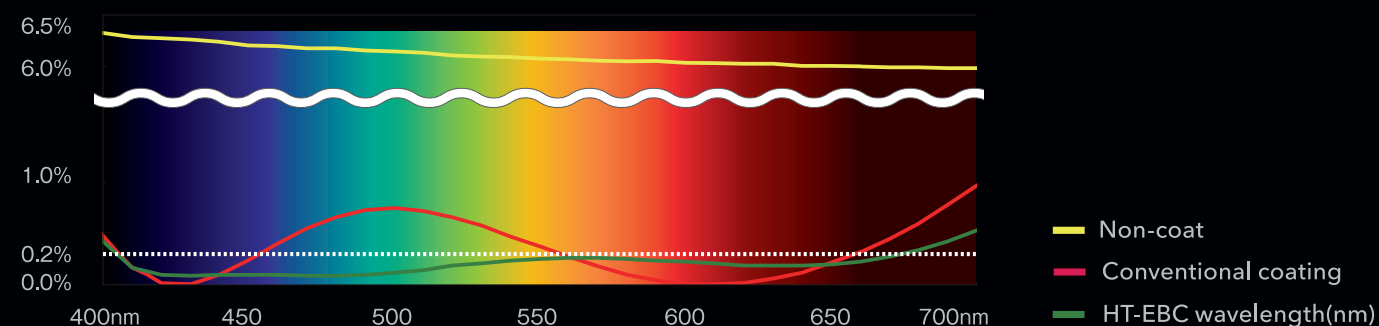
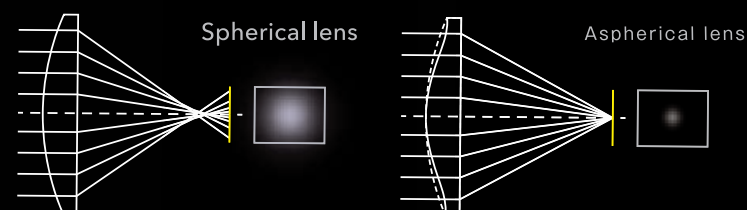

9-Blade Iris for Natural Bokeh

In order to improve the depiction of a more natural out of focus image and a nearly perfect round shape of the aperture, FUJINON PL and E mount cine lenses have an optimal 9-blade iris. Images of bright objects, not in critical focus, will look more natural and pleasing to the eye.

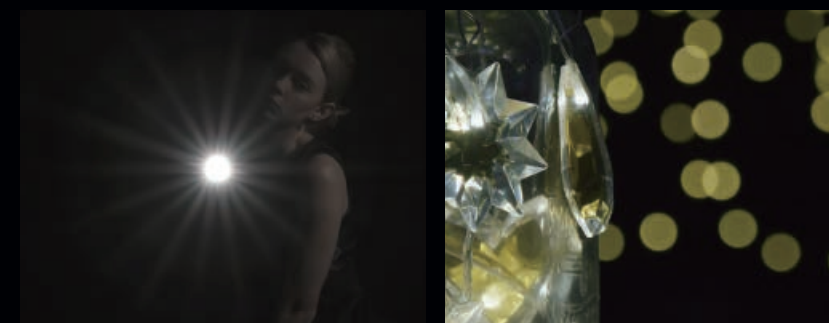

Color Matching

In cinematography, each scene requires different types of lenses depending on focal length. This means the same color balance in all lenses is crucial. FUJINON Cine Lenses are designed to exhibit the same transmission characteristics optimized for each optical element by using various glass materials in ideal balance and by adopting our New HT-EBC multi layer coating. These transmission characteristics reduce time to adjust color in post; therefore overall savings are possible.



Suppress lens breathing

When you are focusing with a conventional DSLR lens, you may notice an unnatural change in the angle of view —making it look as if you are zooming. This effect, called "lens breathing," is suppressed thanks to FUJINON Cine Lenses' front inner focus system. This allows you smooth and comfortable focusing of dramatically important scenes.

FUJINON Cine Lenses Technology

Precise operability capable of responding to the user's feelings and ideas

To faithfully depict the world the cinematographer has imagined, we have adopted a mechanical design that emphasizes manual operability. We respond to the needs of users with scrupulous attention to detail in design and ease of operation, including smooth movement of gear rings to enable precise focusing, uniform 0.8 mm gear pitch, and an original universal font for excellent readability.

Mechanical design for good manual operability

- ◆ Operation is smooth and free of torque changes and jerkiness.
- ◆ Smooth focusing with no torque variation or friction helps accurate focus adjustment.
- ◆ The gear rings for focus, zoom and iris adjustment have a pitch of 0.8M, the same on all FUJINON Cine Lenses, for compatibility with standard cine accessories.
- ◆ An original universal font for markings offers excellent visibility in any shooting situation.
- ◆ The ergonomic design of the detachable servo drive unit mounted on the ZK/XK Series provides a comfortable, balanced grip and achieves the same operational feel as a broadcast TV lens.





Premier Zoom Series

Fujifilm engineers exhaustively developed the HK Premier Series utilizing our expertise and knowledge gained from the lens design process honed over many years. The contrast performance is rich, the resolution - superb. The net results are lenses with excellent overall balance.



4K+ Ultimate High Optical Performance

Fujifilm has developed special high refractive index and low dispersion glass in order to improve the optical balance. The zoom mechanism suppresses aberration change from the WIDE side to TELE end by adopting our exclusive floating method. HK Premier Series lenses employ a special new HT-EBC multi-layer coating technology which reduces flares and ghosts to improve image quality. In addition, the contrast performance is rich with a superb 4K+ resolution. The net result is a lens series with excellent overall balance. The HK Premier Series lenses, with high resolution throughout the zoom range, make a compelling argument for utilizing one zoom lens in place of multiple primes.



Main Features

- ◆ 4K+ Ultimate Optical Performance
- ◆ Focal Lengths from 14.5mm to 400mm are covered by 4 zoom lenses
- ◆ Natural Bokeh (Blur) thanks to 9-Blade Round Iris
- ◆ Color Matching
- ◆ Compatible with both Digital and Film Cameras*
- ◆ 280 Degree Focus Rotation
- ◆ 136mm Front Lens Diameters
- ◆ 0.8mm Cine Gearing
- ◆ Uniformed Sizes and Shapes of Design
- ◆ Available with Feet or Meter Scales

*The lens is optimized by the use of an optical adaptor





Cabrio Series

The ZK Cabrio Series features a unique detachable servo drive unit*. With the drive unit, these lenses operate like traditional Hand-Held TV lenses thanks to the same interface and accessories familiar to TV lens users. On the other hand, with the drive unit removed, this lens has standard 0.8 cine gearing, allowing for the use of traditional third party cine accessories.

*Servo drive unit for ZK 12x25 is optionally available.



Hand-Held Shooting Style with Detachable Servo Grip

ZK Light Weight Series lenses feature advanced "Detachable" drive unit, first in the Light Weight Zoom category. These lenses feature hybrid technology of our broadcast and cine lens technologies in a light weight and compact body. With the drive unit, these lenses can be operated like traditional Hand-Held TV lenses thanks to the same interface and accessories. This is exceptionally helpful in simplifying and reducing set up time. Therefore, it is not necessary to use more complicated cine lens drive systems. In addition, the drive also seamlessly interfaces with wired and wireless cine control systems. On the other hand, with the drive unit removed, these lenses have standard 0.8 cine gearing, allowing for the use of traditional third party cine accessories. Whichever way they are used, the operator will feel comfortable with the lenses.

*In order to use the servo system with a ZK Light Weight Series lens, it is necessary to provide power from the camera to the lens through the camera mount (more than 10V, 1A). If the camera doesn't have capability of supply power to the lens, please arrange an external power source (10 to 30VDC) and optional connection cable.



Main Features

- ◆ Detachable Servo Drive Unit
- ◆ 16 bit High Resolution Encoders are employed
- ◆ LDS* and /i Technology * lens data capable through electric contacts in the mount
- ◆ Outstanding Performance Designed for 4K Cameras
- ◆ Back Focus Adjustment with Macro Function
- ◆ Natural Bokeh (Blur) thanks to 9-Blade Round Iris
- ◆ 0.8mm Cine Gearing
- ◆ 200 Degree Focus Rotation
- ◆ Luminous Barrel Markings
- ◆ Available with Feet or Meter Scales

*LDS (Lens Data System): Lens communication feature provided from ARRI
 *i Technology: Lens communication feature provided from Cooke.





Cabrio XK Series

The XK Cabrio Series is also equipped with the operational features of the ZK Cabrio Series. The lens offers 4K compatible optical performance and covers a wide range of focal length from 20mm to 120mm. It also realizes T3.5 brightness in the entire zoom range. Various scenes can be shot with this single lens.



The detachable servo drive unit enables all kinds of shots to be covered using a single lens

As a full manual cine lens, the XK Series is endowed with the operational feel of a conventional cine lens thanks to a standard-equipped detachable servo drive unit made popular in the ZK Series models. Mounting the servo drive unit ensures an operational feel and ease of use similar to a broadcast TV lens in which zoom, focus, and iris are adjusted via servo operation. This enables the cinematographer to express a cinematic production style even in broadcast program production applications. This series realizes T3.5 brightness across the entire range of focal lengths from 20-120 mm, and truly demonstrates its capabilities in combination with the compact 4K-compatible cameras that have come into widespread use in recent years. Even in environments with constraints on shooting equipment, such as outdoor settings, you can handle any shooting situation using a single lens without the need to swap lenses.



Main Features

- ◆ Detachable Servo Drive Unit
- ◆ 16 bit High Resolution Encoders are employed
- ◆ LDS* and /i Technology * lens data capable through electric contacts in the mount
- ◆ Outstanding Performance Designed for 4K Cameras
- ◆ Back Focus Adjustment with Macro Function
- ◆ Natural Bokeh (Blur) thanks to 9-Blade Round Iris
- ◆ 0.8mm Cine Gearing
- ◆ 200 Degree Focus Rotation
- ◆ Luminous Barrel Markings
- ◆ Available with Feet or Meter Scales

*LDS (Lens Data System); Lens communication feature provided from ARRI
 *i Technology; Lens communication feature provided from Cooke.





MK Series

These lenses have world-class performance and quality ingrained in their DNA. Now, with the debut of the MK Lens series, that heritage finds a new form. Fujifilm has developed a new pair of cinema lenses to resolve the less-than-satisfactory aspects of DSLR lenses when used for cine applications. These new lenses produce the high performance and high-quality images demanded by newly developing production markets such as movie distribution services, independent film production, and wedding videos.



Comfortable operability to meet the demands of video production locations

Optimizing the optical and mechanical design for a dedicated cine lens makes it possible to suppress both the focal shift and optical axis shift during zooming, as well as viewing angle changes (breathing) during focusing, that have plagued interchangeable lens for digital cameras. In addition, these lenses feature triple lens rings that enable independent manual operation for focus, zoom, and iris. And the gear pitch of all operational rings is standardized to 0.8M (module). Also, designing the focus ring to rotate through a wide 200-degree range makes precise focusing possible.



Main Features

- ◆ Suppress both focus shifts while zooming and lens breathing
- ◆ Suppress optical axis shifts while zooming
- ◆ MK lenses feature outstanding optical performance and low distortion from the center to the corners across the entire zoom range
- ◆ Color is standardized in line with all of the FUJINON HK, ZK, and XK series, simplifying the calibration of color grading when you use multiple lenses together
- ◆ T2.9 speed across the entire zoom range
- ◆ Compact, lightweight body thanks to Super 35mm sensor compatibility and dedicated E-mount design



Lens Line Up & Specification

Premier Zoom Series



Model Name	HK3.1x14.5	HK4.7x18	HK7.5x24	HK5.3x75
Application	35mm PL Mount Camera	35mm PL Mount Camera	35mm PL Mount Camera	35mm PL Mount Camera
Focal Length	14.5-45mm	18-85mm	24-180mm	75-400mm
Zoom Ratio	3.1 ×	4.7 ×	7.5 ×	5.3 ×
T-No.	T2.0	T2.0	T2.6	T2.8(75-290mm) T3.8(400mm)
Iris Blades	9	9	9	9
M.O.D.from Image Planes	0.71m / 2'4"	0.82m / 2'9"	1.24m / 4'1"	2m / 6'9"
Object Dimensions at M.O.D. 1.78 : 1 Aspect Ratio*	14.5mm 693 × 390mm 45mm 215 × 121mm	18mm 656 × 369mm 85mm 139 × 78mm	24mm 924 × 520mm 180mm 119 × 67mm	75mm 580 × 326mm 400mm 113 × 64mm
Angular Field of View 1.78 : 1 Aspect Ratio*	14.5mm 79°13' × 49°56' 45mm 29°52' × 17°04'	18mm 67°23' × 41°07' 85mm 16°04' × 9°05'	24mm 53°08' × 31°25' 180mm 7°38' × 4°18'	75mm 18°11' × 10°17' 400mm 3°26' × 1°56'
Focus Rotation	280°	280°	280°	280°
Zoom Rotation	160°	160°	160°	160°
Apporox. Size (Φ×Length)	Φ 136 × 310mm	Φ 136 × 352mm	Φ136 × 405mm	Φ136 × 444mm
Apporox. Mass	6.5kg	7.0kg	8.9kg	9.1kg

*Sensor Size: 24.0×13.5mm

Cabrio XK Series



Model Name	XK6x20
Application	35mm PL Mount Camera
Focal Length	20-120mm
Zoom Ratio	6 ×
T-No.	T3.5
Iris Blades	9
M.O.D.from Image Planes	1.1m / 3'7"
Object Dimensions at M.O.D. 1.78 : 1 Aspect Ratio*	20mm 1109 × 624mm 120mm 182 × 102mm
Angular Field of View 1.78 : 1 Aspect Ratio*	20mm 63°41' × 38°30' 120mm 11°49' × 6°40'
Focus Rotation	200°
Zoom Rotation	90°
Apporox. Size (Φ×Length)	Φ114 × 239mm
Apporox. Mass	2.9kg(with Drive Unit) / 2.4kg(without Drive Unit)

*Sensor Size: 24.84×13.97mm

Cabrio Series



Model Name	ZK2.5x14	ZK4.7x19	ZK3.5x85	ZK12x25
Application	35mm PL Mount Camera	35mm PL Mount Camera	35mm PL Mount Camera	35mm PL Mount Camera
Focal Length	14-35mm	19-90mm	85-300mm	25-300mm
Zoom Ratio	2.5 ×	4.7 ×	3.5 ×	12 ×
T-No.	T2.9	T2.9	T2.9(85-218mm) T4.0(300mm)	T3.5(25-273mm) T3.85(300mm)
Iris Blades	9	9	9	9
M.O.D.from Image Planes	0.6m / 2'	0.85m / 2'10"	1.2m / 4'	1.2m / 4'
Object Dimensions at M.O.D. 1.78 : 1 Aspect Ratio*	14mm 701 × 394mm 35mm 275 × 155mm	19mm 917 × 516mm 90mm 193 × 109mm	85mm 274 × 154mm 300mm 79 × 44mm	25mm 937 × 527mm 300mm 77 × 43mm
Angular Field of View 1.78 : 1 Aspect Ratio*	14mm 88°52' × 57°45' 35mm 42°49' × 24°53'	19mm 71°41' × 44°14' 90mm 17°20' × 9°48'	85mm 18°21' × 10°23' 300mm 5°14' × 2°57'	25mm 57°32' × 34°19' 300mm 5°14' × 2°57'
Focus Rotation	200°	200°	200°	280°
Zoom Rotation	120°	120°	120°	120°
Apporox. Size (Φ×Length)	Φ 114 × 231 mm	Φ 114 × 226mm	Φ 114 × 249mm	Φ136 × 401mm
Apporox. Mass	2.9kg(with Drive Unit) / 2.4kg(without Drive Unit)	2.8kg(with Drive Unit) / 2.3kg(without Drive Unit)	3.1kg(with Drive Unit) / 2.6kg(without Drive Unit)	8.4kg(without Drive Unit)

*Sensor Size: 27.45×15.44mm

ZK12x25 servo drive unit is optionally available



Lens Line Up & Specification

MK Series

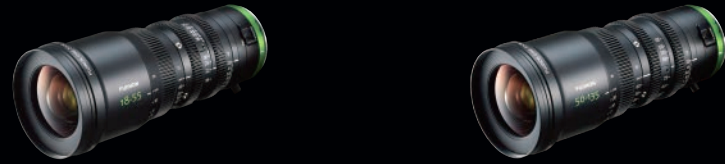

Model Name	MK18-55mm T2.9	MK50-135mm T2.9
Application	Super 35mm/APS-C E-mount Camera	Super 35mm/APS-C E-mount Camera
Focal Length	18-55mm	50-135mm
Zoom Ratio	3.0 ×	2.7 ×
T-No.	T2.9	T2.9
Iris Blades	9	9
M.O.D.from Image Planes	0.85m / 2'9" (with macro function 0.38m / 1'2.9")	1.2m / 3'11" (with macro function 0.85m / 2'9")
Object Dimensions at M.O.D. 1.78 : 1 Aspect Ratio*	18mm 924 × 520mm 55mm 291 × 164mm	50mm 534 × 300mm 135mm 196 × 110mm
Angular Field of View 1.78 : 1 Aspect Ratio*	18mm 69.2° × 42.4° 55mm 25.5° × 14.5°	50mm 27.9° × 15.9° 135mm 10.5° × 5.9°
Focus Rotation	200°	200°
Zoom Rotation	90°	90°
Approx. Size (Φ×Length)	Φ87 × 206.3mm	Φ87 × 206.3mm
Approx. Mass	980g	980g

*Sensor Size:24.84×13.97mm



Lens System Configuration & Control Accessories

The ZK/XK Series support zoom demand and focus demand controllers for existing broadcast TV lenses. They offer a wide range of operating styles for studio and remote production applications.

Cinema Lens System Configuration

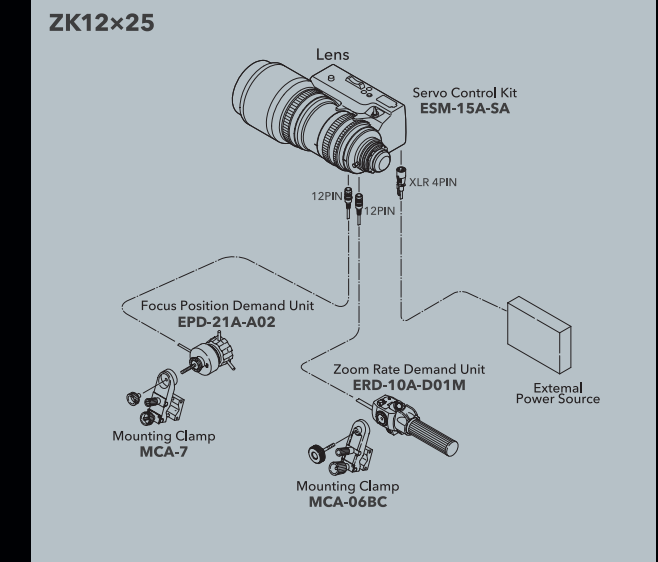
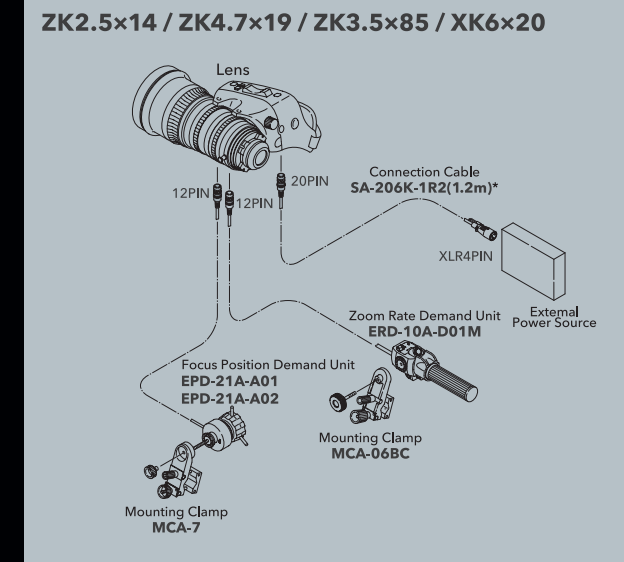

*Connection cable for external power source is necessary when the power source (over 10V, 1A) can't be supplied from a camera.

Control Accessories List

		Description	Model Name
Focus Demand	Digital	Digital Focus Position Demand Mounting Clamp	EPD-4A-E12A MCA-06BC
	Standard	Standard Focus Position Demand Mounting Clamp	EPD-21A-A02 MCA-7
Zoom Demand	Digital	Digital Zoom Demand (Featured Iris Remote Control) Mounting Clamp	ERD-10A-D01M MCA-06BC
	Standard	Focus Position Demand Mounting Clamp	ERD-20A-A02 MCA-7
Other		Connection Cable for EPD-4A-E12A	EBF-1
		Lens Hood for ZK4.7x19, ZK3.5x85	HS-304A-114
		Lens Hood for ZK2.5x14	HS-304B-114
		Digital Servo Module (Designed for ZK12x25)	ESM-15A-SA
		Power Source Cable (Lens:20pin - XLR4pin), L=120cm	SA-206K-1R2
		Power Source Cable (Lens:20pin - D-Tap), L=120cm	SA-206X-1R2
		Power Source Cable (Lens:20pin - Camera:12pin), L=120cm	SA-206M-1R2
		Power Source Cable (Lens:20pin - Camera:12pin), L=40cm	SA-206M-R40
		Power Source Cable (Lens:20pin - Camera:12pin), L=25cm	SA-206M-R25

