

Ovation

P-56FC

User Manual

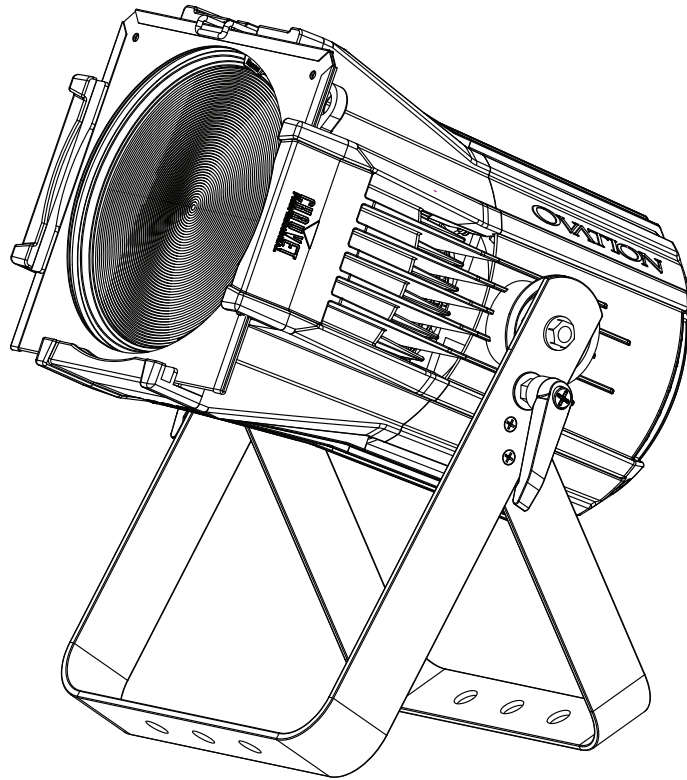

CHAUVET
PROFESSIONAL

EDITION NOTES

The Ovation P-56FC User Manual includes a description, safety precautions, installation, programming, operation, and maintenance instructions for the Ovation P-56FC.

Trademarks

CHAUVET, the Chauvet logo, and Ovation P-56FC are registered trademarks or trademarks of Chauvet & Sons, LLC (d/b/a Chauvet and Chauvet Lighting) in the United States and other countries. Other company and product names and logos referred to herein may be trademarks of their respective companies.

Copyright Notice

The works of authorship contained in this manual, including, but not limited to, all design, text, and images are owned by Chauvet.

© Copyright 2019 Chauvet & Sons, LLC. All rights reserved.

Electronically published by Chauvet in the United States of America.

Manual Use

Chauvet authorizes its customers to download and print this manual for professional information purposes only. Chauvet expressly prohibits the usage, copy, storage, distribution, modification, or printing of this manual or its content for any other purpose without written consent from Chauvet.

Document Printing

For best results, print this document in color, on letter size paper (8.5 x 11 in), double-sided. If using A4 paper (210 x 297 mm), configure the printer to scale the content accordingly.

Intended Audience

Any person installing, operating, and/or maintaining this product should completely read through the guide that shipped with the product, and this manual, before installing, operating, or maintaining this product.

Disclaimer

Chauvet believes that the information contained in this manual is accurate in all respects. However, Chauvet assumes no responsibility and specifically disclaims any and all liability to any party for any loss, damage, or disruption caused by any errors or omissions in this document, whether such errors or omissions result from negligence, accident, or any other cause. Chauvet reserves the right to revise the content of this document without any obligation to notify any person or company of such revision; however, Chauvet has no obligation to make, and does not commit to make, any such revisions. Download the latest version from www.chauvetprofessional.com

Document Revision

This Ovation P-56FC User Manual is the 4th edition of this document. Go to www.chauvetprofessional.com for the latest version.

TABLE OF CONTENTS

1. Before You Begin	3
What Is Included	3
Claims	3
Manual Conventions	3
Symbols	3
Safety Notes.....	4
Personal Safety.....	4
Mounting and Rigging	4
Power and Wiring.....	4
Operation	4
Expected LED Lifespan.....	4
2. Introduction	5
Description	5
Features.....	5
Product Overview.....	6
Product Dimensions.....	7
3. Setup	8
AC Power.....	8
AC Plug.....	8
Power Linking.....	8
DMX Linking.....	8
DMX Personalities.....	8
Remote Device Management (RDM).....	8
Master/Slave Connectivity.....	8
Mounting	9
Orientation.....	9
Rigging.....	9
Procedure.....	9
Alternate Lens Changing Procedure	10
4. Operation	11
Control Panel Operation.....	11
Control Options	11
Programming.....	11
Menu Map	11
Configuration (DMX)	14
Control Personalities	14
Starting Address.....	14
DMX Values	14
15-Ch	14
13-Ch	15
12-Ch	15
10-Ch	16
7-Ch	16
5-Ch	16
3-Ch	16
1-Ch	16
HSV.....	16
Virtual Color Wheel	17
Configuration (Standalone)	18
Static Mode	18
Auto Programs	18

Master/Slave	19
Dimmer Profiles.....	19
White Balance	19
LED Frequency	19
Fan Mode.....	19
Back Light	20
System Information	20
Factory Reset.....	20
5. Technical Information	21
Product Maintenance	21
6. Technical Specifications	22
Photometrics Chart	23
Returns.....	24
Contact Us	25

BEFORE YOU BEGIN

1. BEFORE YOU BEGIN

What Is Included

- Ovation P-56FC
- Gel frame holder (7.5 in/191 mm accessories)
- Neutrik powerCON power cord
- Medium and wide lenses
- Quick Reference Guide

Claims

Carefully unpack the product immediately and check the container to make sure all the parts are in the package and are in good condition.





If the box or the contents (the product and included accessories) appear damaged from shipping, or show signs of mishandling, notify the carrier immediately, not Chauvet. Failure to report damage to the carrier immediately may invalidate your claim. In addition, keep the box and contents for inspection.

For other issues, such as missing components or parts, damage not related to shipping, or concealed damage, file a claim with Chauvet within 7 days of delivery.

Manual Conventions

Convention	Meaning
1–512	A range of values
50/60	A set of values of which only one can be chosen
<SET>	A button on the product's control panel
Settings	A product function or a menu option

Symbols

Symbol	Meaning
	Electrical warning. Not following these instructions may cause electrical damage to the product, accessories, or the user.
	Critical installation, configuration, or operation information. Not following these instructions may make the product not work, cause damage to the product, or cause harm to the operator.
	Important installation or configuration information. The product may not function correctly if this information is not used.
	Useful information.



The term “DMX” used throughout this manual refers to the USITT DMX512-A digital data transmission protocol.

Safety Notes

Read all the following safety notes before working with this product. These notes contain important information about the installation, usage, and maintenance of this product.



This product contains no user-serviceable parts. Any reference to servicing in this User Manual will only apply to properly trained, certified technicians. Do not open the housing or attempt any repairs.



All applicable local codes and regulations apply to proper installation of this product.

Personal Safety

- Avoid direct eye exposure to the light source while the product is on.
- Always disconnect the product from the power source before cleaning or replacing the fuse.
- Always connect the product to a grounded circuit to avoid the risk of electrocution.
- Do not touch the product's housing when operating because it may be very hot.

Mounting and Rigging

- DO NOT operate this product outdoors or in any location where dust, excessive heat, water, or humidity may affect it. (IP20).
- CAUTION: When transferring product from extreme temperature environments, (e.g., cold truck to warm, humid ballroom) condensation may form on the internal electronics of the product. To avoid causing a failure, allow product to fully acclimate to the surrounding environment before connecting it to power.
- Mount this product in a location with adequate ventilation, at least 20 in (50 cm) from adjacent surfaces.
- Make sure there are no flammable materials close to the product when operating.
- When hanging this product, always secure to a fastening device using a safety cable.

Power and Wiring

- Always make sure you are connecting the product to the proper voltage in accordance with the specifications in this manual or on the product's specification label.
- Never connect the product to a dimmer pack or rheostat.
- Never disconnect this product by pulling or tugging on the power cable.

Operation

- Do not operate this product if there is damage on the housing, lenses, or cables. Have the damaged parts replaced by an authorized technician at once.
- Do not cover the ventilation slots when operating to avoid internal overheating.
- The maximum ambient temperature is 113 °F (45 °C). Do not operate the product at higher temperatures.
- In the event of a serious operation problem, stop using this product immediately!



If your Chauvet product requires service, contact Chauvet Technical Support.

Expected LED Lifespan

LEDs gradually decline in brightness over time, primarily because of heat. LEDs that are arranged in clusters experience higher operating temperatures than single LEDs. For this reason, operating clustered LEDs at their fullest intensity significantly reduces the LEDs' lifespan. Under normal conditions, this lifespan is 40,000 to 50,000 hours. If extending this lifespan is vital, lower the operating temperature by improving the ventilation around the product, thus, reducing the ambient temperature. In addition, limiting the overall projection intensity may extend the LEDs' lifespan.

2. INTRODUCTION

Description

The Ovation P-56FC is a compact, silent par that produces a homogenized, single-source, flat field of light with high CRI. The bright product utilizes the same advanced full color-mixing RGBAL LED system found in the popular Ovation E-910FC ellipsoidal. Interchangeable lens plates are included for medium and wide beam angles, and the unit accepts standard 7.5" beam shaping accessories. Designed for theatrical and studio applications, the Ovation P-56FC features extremely smooth 16-bit dimming, and RDM and PWM for ease of setup.

Features

- Operating modes:
 - 1-Ch: dimmer
 - 3-Ch: dimmer, Virtual Color Wheel, color temperature
 - 5-Ch: RGBAL control
 - 7-Ch: RGBAL control, strobe
 - 10-Ch: 16-bit dimmer, RGBAL control, strobe, Virtual Color Wheel, color temperature
 - 12-Ch: dimmer, RGBAL control, strobe, Virtual Color Wheel, color temperature, auto programs, auto speed, and dimmer speed mode
 - 13-Ch: 16-bit dimmer, 16-bit RGBAL control, strobe
 - 15-Ch: 16-bit dimmer, 16-bit RGBAL control, strobe, Virtual Color Wheel, color temperature, HSV: hue, saturation, value
- Full color PAR style fixture with homogenized single source of light
- Interchangeable lens plates included for medium and wide beam angles
- Flat, even field of light
- Quiet operation for use in any situation with fan speed control
- RDM and variable Pulse Width Modulation for setup ease
- Accepts standard 7.5" beam shaping accessories
- 16-bit dimming resolution for smooth fades

Product Overview

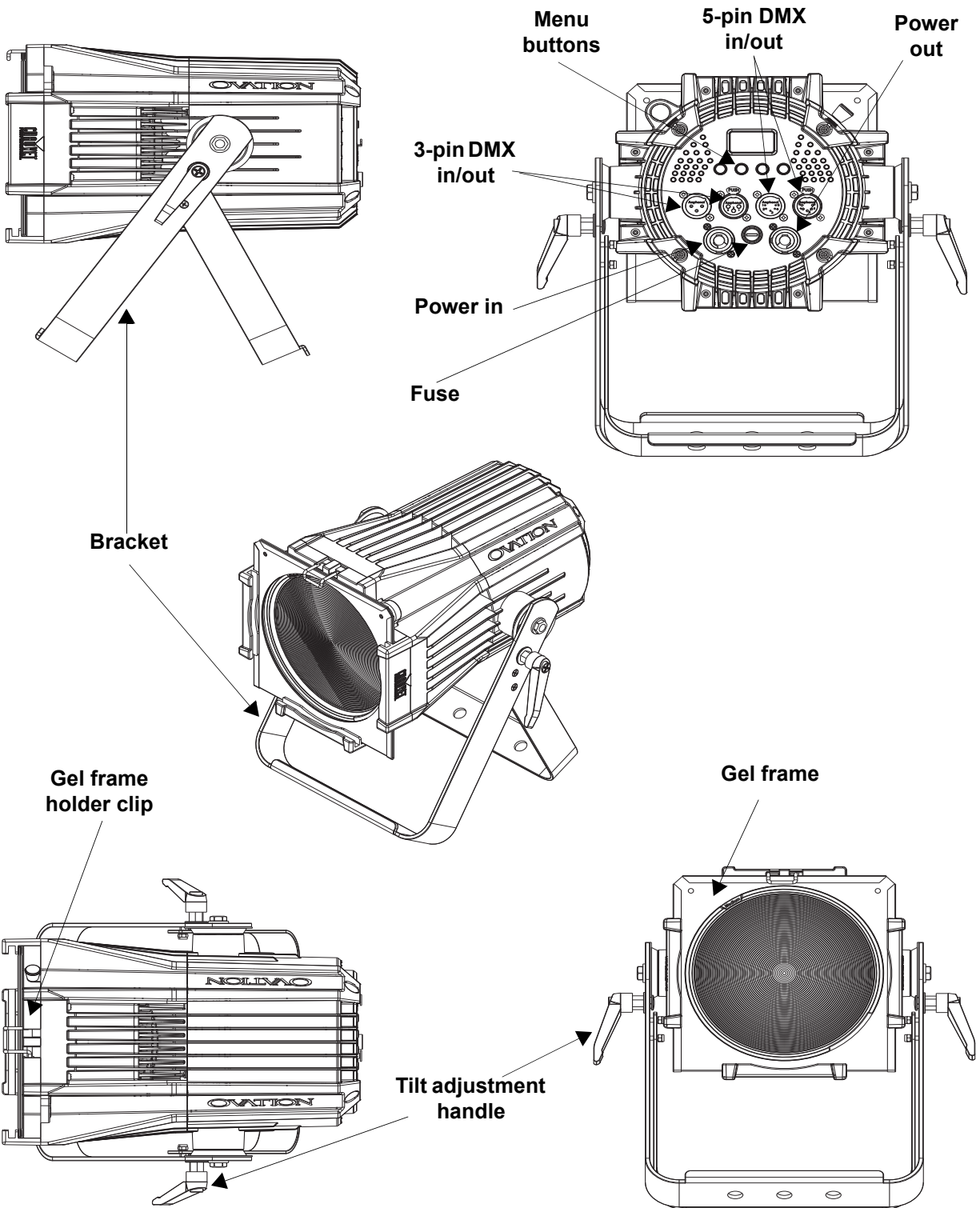

Product Dimensions

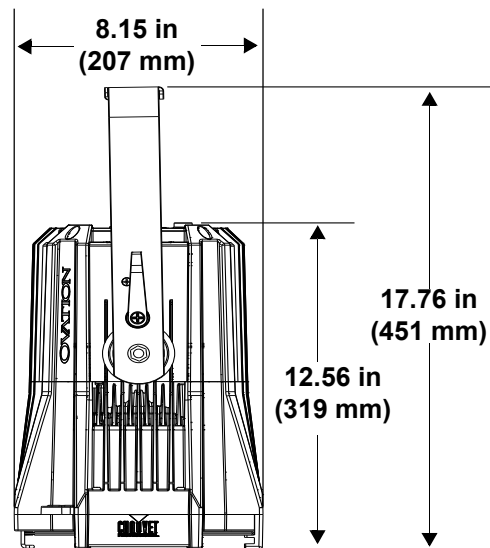
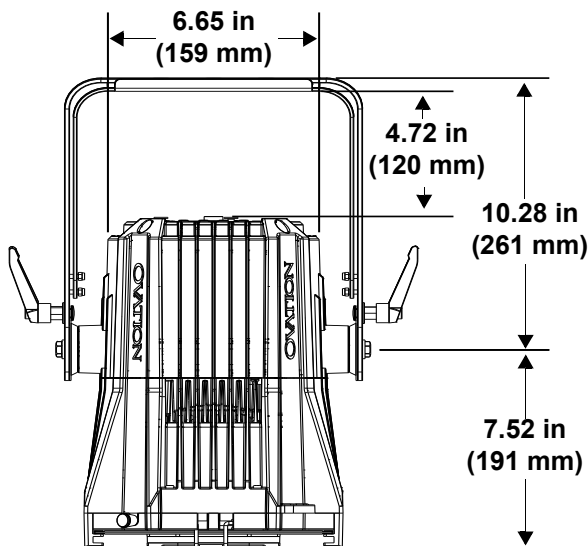
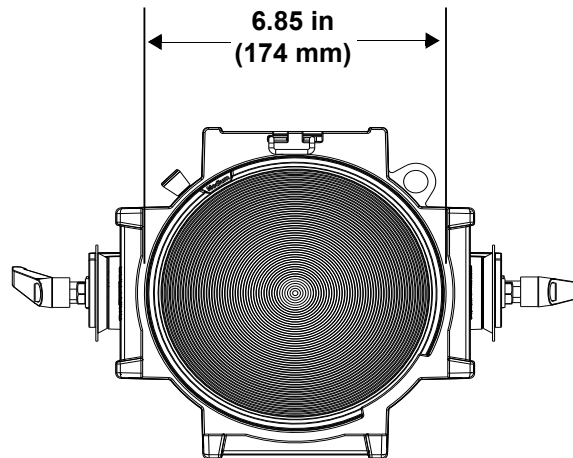
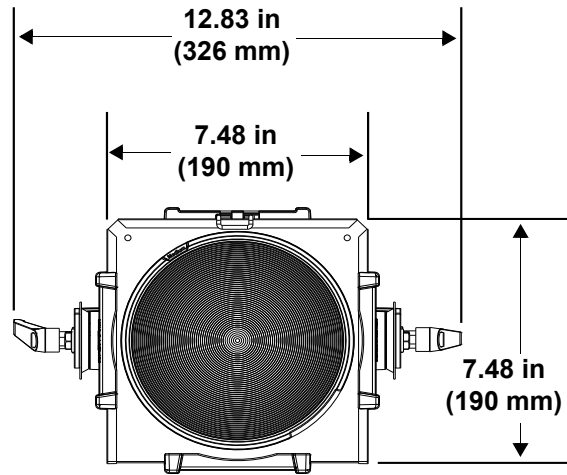
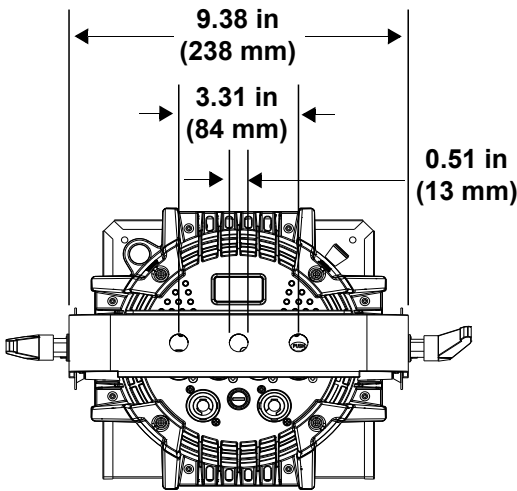

3. SETUP

AC Power

Each Ovation P-56FC has an auto-ranging power supply that works with an input voltage range of 100 to 240 VAC, 50/60 Hz. To determine the power requirements for each Ovation P-56FC, refer to the label affixed to the product. You can also refer to the Technical Specifications chart in this manual. The listed current rating indicates the maximum current draw during normal operation. For more information, download Sizing Circuit Breakers from the Chauvet website: www.chauvetprofessional.com.



- **Always connect the product to a protected circuit (circuit breaker or fuse). Make sure the product has an appropriate electrical ground to avoid the risk of electrocution or fire.**
- **To eliminate unnecessary wear and improve its lifespan, during periods of non-use completely disconnect the product from power via breaker or by unplugging it.**



Never connect the product to a rheostat (variable resistor) or dimmer circuit, even if the rheostat or dimmer channel serves only as a 0 to 100% switch.

AC Plug

The Ovation P-56FC comes with a power input cord terminated with a Neutrik powerCON A connector on one end and an Edison plug on the other end (U.S. market). If the power input cord that came with your product has no plug, or if you need to change the plug, use the table below to wire the new plug.

Connection	Wire (U.S.)	Wire (Europe)	Screw Color
AC live	Black	Brown	Yellow/brass
AC neutral	White	Blue	Silver
AC ground	Green/yellow	Green/yellow	Green

Power Linking

The product supports power linking. You can power link up to 9 products at 120 V; up to 16 at 208 V; or up to 17 at 230 V. This product comes with a power input cord. Power-linking cables are available from Chauvet for purchase.

DMX Linking

You can link the Ovation P-56FC to a DMX controller using a 3- or 5-pin DMX connection. If using other DMX-compatible products with this product, you can control each individually with a single DMX controller.

DMX Personalities

The Ovation P-56FC uses a 3- or 5-pin DMX data connection for the **1-Ch, 3-Ch, 5-Ch, 7-Ch, 10-Ch, 12-Ch, 13-Ch, 15-Ch**, and **HSV** DMX personalities.

- Refer to the Introduction for a brief description of each DMX personality.
- Refer to the Operation chapter to learn how to configure the Ovation P-56FC to work in these personalities.
- The DMX Values section provides detailed information regarding the DMX personalities.

Remote Device Management (RDM)

Remote Device Management, or RDM, is a standard for allowing DMX-enabled devices to communicate bi-directionally along existing DMX cabling. Check the DMX controller's User Manual or with the manufacturer, as not all DMX controllers have this capability. The Ovation P-56FC supports RDM protocol that allows feedback to make changes to menu map options.

Master/Slave Connectivity

The Master/Slave mode allows a Ovation P-56FC (the master) to control one or more Ovation P-56FC products (the slaves) without a DMX controller. One Ovation P-56FC becomes the master when running an auto or custom program, or by being in a Static mode.

You must configure each slave's control panel to operate in Slave mode. During Master/Slave operation, the slaves will operate in unison with the master.



DO NOT connect a DMX controller to products operating in Master/Slave mode. The DMX controller signals may interfere with the signals from the master.



- The [Operation](#) section of this manual provides detailed instructions on how to configure the master and slaves.
- If you are not familiar with DMX standards or Master/Slave connectivity, download the DMX Primer from the Chauvet website www.chauvetprofessional.com for more information.

Mounting

Before mounting the product, read and follow the safety recommendations indicated in the Safety Notes. For our CHAUVET Professional line of mounting clamps, go to <http://trusst.com/products/>.

Orientation

Always mount this product in a safe position, making sure there is adequate room for ventilation, configuration, and maintenance.

Rigging

Chauvet recommends using the following general guidelines when mounting this product.

- Before deciding on a location for the product, make sure there is easy access to the product for maintenance and programming purposes.
- Make sure that the structure onto which you are mounting the product can support the product's weight. See the [Technical Specifications](#) for weight information.
- When mounting the product overhead, always use a safety cable. Mount the product securely to a rigging point, whether an elevated platform or a truss.
- When rigging the product onto a truss, use a mounting clamp of appropriate weight capacity.
- When power linking multiple products, mount the products close enough for power-linking cables to reach.
- The bracket adjustment knobs allow for directional adjustment when aiming the product to the desired angle. Only loosen or tighten the bracket knobs manually. Using tools could damage the knobs.

Procedure

The Ovation P-56FC comes with a double-bracketed yoke to which you can either attach mounting clamps for hanging or simply use as a floor stand. You must supply the mounting clamps. Make sure the clamps are capable of supporting the weight of this product. Use at least one mounting point per product. For the CHAUVET Professional line of mounting clamps, go to <http://www.trusst.com/products>.

Mounting Diagram

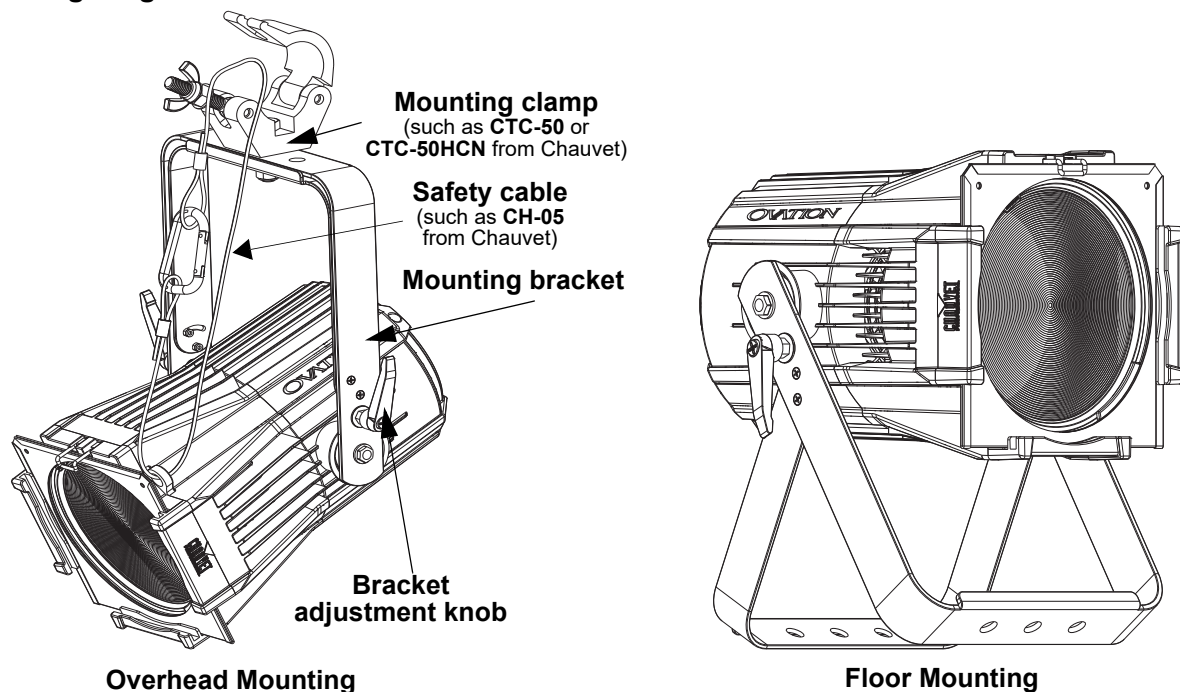

Alternate Lens Changing Procedure

The Ovation P-56FC has the ability to have different types of lenses installed. The interchangeable lenses allow the product to have alternate beam angles.

To remove a lens:

1. Pull knob up.
2. Grab the tab on the lens and pull it out of the fixture.



Diffusion filter media (gel) attached to the fixture behind the lens may stick to the lens being removed. Use caution when removing to prevent damage to the diffusion gel.

To install a lens:

1. Pull knob up.
2. Insert the bottom of the lens at approx the 5 o'clock position with the lens tab located at the 11 o'clock position.
3. Push the top of the lens in and release the knob..



The lens type is molded into the tab.

Mounting Diagram

**Pull knob up to release
and change the lens**

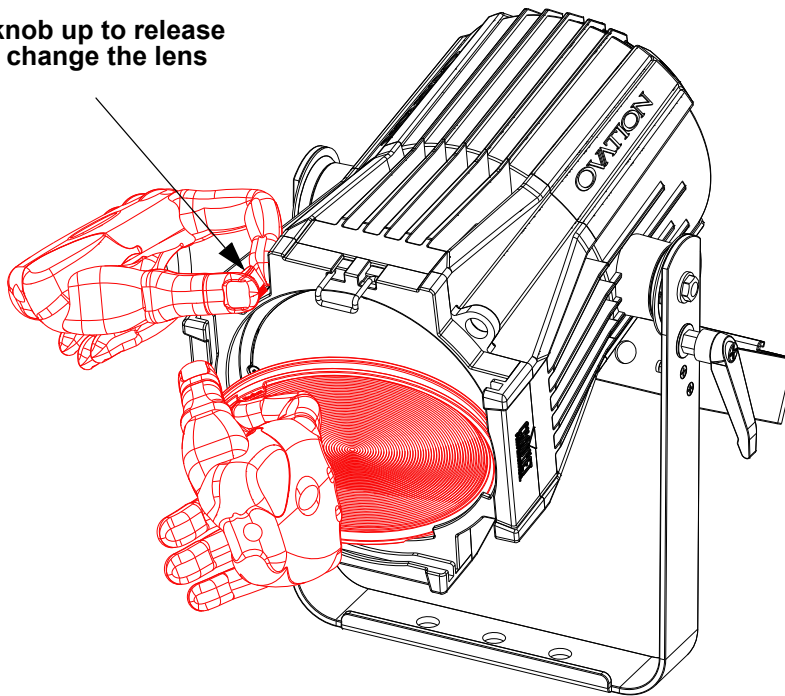

4. Operation

Control Panel Operation

Button	Function
<MENU>	Exits from the current menu or function
<ENTER>	Enables the currently displayed menu or sets the currently selected value in to the current function
<UP>	Navigates upward through the menu list or increases the numeric value when in a function
<DOWN>	Navigates downward through the menu list or decreases the numeric value when in a function

Control Options

Set the Ovation P-56FC starting address in the 001–512 DMX range. This enables control of up to 34 products in the 15-channel **15-Ch** personality.

Programming

Refer to the Menu Map to understand the menu options. The menu map shows the main level and a variable number of programming levels for each option.

- To go to the desired main level, press <MENU> repeatedly until the option shows on the display. Press <ENTER> to select. This will take you to the first programming level for that option.
- To select an option or value within the current programming level, press <UP> or <DOWN> until the option shows on the display. Press <ENTER> to select. In this case, if there is another programming level, you will see that first option, or you will see the selected value.
- Press <MENU> repeatedly to exit to the previous main level.

Menu Map

Main Level	Programming Levels		Description		
DMX Address	Address	001-512*	Selects DMX address (*highest channel restricted to personality chosen)		
DMX Channels	1-Ch	Virtual Color Wheel	< _ _ _ _ > 1-channel: dimmer. See Virtual Color Wheel Chart		
		Color Temperature	< _ _ _ _ > See Preset Color Temperature Chart		
		Manual Color Mixer	Red	000–255	Combine red, green, blue, amber, and lime to make a custom color (0–100%)
			Green		
			Blue		
	Amber				
	Lime				
		3-Ch	3-channel: dimmer, Virtual Color Wheel, color temperature		
		5-Ch	5-channel: RGBAL		
		7-Ch	7-channel: dimmer, RGBAL, strobe		
	10-Ch	10-channel: 16-bit dimmer, RGBAL, strobe, Virtual Color Wheel, color temperature			
	12-Ch	12-channel: dimmer, RGBAL, strobe, Virtual Color Wheel, color temperature, auto programs, auto speed, dimmer speed mode			
	13-Ch	13-channel: 16-bit dimmer, 16-bit RGBAL, strobe			
	15-Ch	15-channel: 16-bit dimmer, 16-bit RGBAL, strobe, Virtual Color Wheel, color temperature			
	HSV	3-channel: hue, saturation, value			

Main Level	Programming Levels		Description			
Virtual Color Wheel	Virtual Color Wheel	C3050 - Md Yellow	Dimmer 000–255 Virtual color wheel simulates the output of each gel color. Refer to the Virtual Color Wheel Chart section for specific values.			
		C3040 - Lt Yellow				
		C3240 - Amb Yellow				
		C2340 - VLt Amber				
		C2040 - Lt Amber				
		C2050 - Md Amber				
		C2060 - Dk Amber				
		C1050 - Lt Red				
		C1080 - Md Red				
		C1020 - NC Pink				
		C1030 - Md Pink				
		C1630 - Dk Pink				
		C1250 - Md Red Amber				
		C1060 - Dk Red Amber				
		C1650 - Magenta				
		C6170 - Dk Magenta				
		C6020 - Lt Lavender				
		C5030 - Lt Blue				
		C5020 - VLt Blue				
		C5430 - Lt Blue2				
		C5070 - Blue				
		C5050 - Md Blue				
		C5060 - Dk Blue				
		C5690 - Indigo				
		C5080 - VDk Blue				
		C5081 - VDk Blue2				
		C4370 - Yel Green				
		C4070 - Green				
		C4550 - Turquoise				
		C4560 - Aqua				
		C4570 - Blue Green				
		Color Temperature		Color Temperature	2800K	Dimmer 000–255 Preset white color temperatures. Emulates a tungsten lamp at the specified color temperature. Refer to the Preset Color Temperature Chart section for specific values.
					3000K	
3200K						
3500K						
4000K						
4500K						
5000K						
5600K						
6000K						
6500K						
Manual Color Mixer	Manual Color Mixer	Red	000–255 Combine red, green, blue, amber, and lime to make a custom color (0–100%)			
		Green				
		Blue				
		Amber				
		Lime				

Main Level	Programming Levels		Description	
Auto Show	Auto 1	1-100	Selects automatic programs and auto program speed	
	Auto 2			
	Auto 3			
	Auto 4			
	Auto 5			
Master/ Slave	Master		Master mode	
	Slave		Slave mode	
Dimmer Mode	Off		Linear dimmer	
	Dimmer 1		Fast dimmer curve	
	Dimmer 2		Medium dimmer curve	
	Dimmer 3		Slow dimmer curve	
White Balance	Off		Uses factory default white setting	
	Manual	Red	125-255	Sets red LED maximum value
		Green		Sets green LED maximum value
		Blue		Sets blue LED maximum value
		Amber		Sets amber LED maximum value
		Lime		Sets lime LED maximum value
LED Frequency	600Hz		Selects the PWM output frequency	
	1200Hz			
	2000Hz			
	4000Hz			
	6000Hz			
	25KHz			
Fan Mode	Auto		Sets the fan to auto mode	
	On		Sets the fan to always on	
	Off		Sets the fan to always off	
	Silent		Sets the fan to silent	
Back Light	10S		Turns off display backlight after 10 seconds of inactivity	
	30S		Turns off display backlight after 30 seconds of inactivity	
	2M		Turns off display backlight after 2 minutes of inactivity	
	Always On		Display backlight always on	
Information	Fixture Hours	<_ _ _ _H>	Shows total product hours	
	Version	<V _ _>	Shows installed software version	
	UID	<_ _ _ _ _ _ _ _>	Shows product UID	
Reset Factory	No		Reset to factory defaults	
	Yes			



WARNING: When operating in Fan Mode: Off, the fixture will become hotter to the touch than when using other fan modes. Use proper protective equipment to prevent burns. Keep a safe distance from flammable objects.



NOTICE: When operating in Fan Mode: Off, output of the fixture will be reduced and will not reach the same levels as when using other fan modes.

Configuration (DMX)

Use control configurations to operate the product with a DMX controller.

Control Personalities

This setting allows you to choose a particular control personality.

1. Go to the **DMX Channel** main level.
2. Select the desired personality (see table below).

Personality	Channels	Personality	Channels
15-Ch	15	7-Ch	7
13-Ch	13	5-Ch	5
12-Ch	12	3-Ch	3
10-Ch	10	HSV	3



- See the [Starting Address](#) section for the highest starting address you can select for each personality.
- Make sure that the starting addresses on the various products do not overlap due to the new personality setting.

Starting Address

Each product will respond to a unique starting address from the DMX controller. All products with the same starting address will respond in unison.

1. Go to the **DMX Address** main level.
2. Select the starting address (**001–510**).

The highest recommended starting address for each DMX mode is as follows:

Personality	Address	Personality	Address
15-Ch	498	7-Ch	506
13-Ch	500	5-Ch	508
12-Ch	501	3-Ch	510
10-Ch	503	HSV	510

DMX Values

15-Ch

Channel	Function	Value	Percent/Setting
1	Dimmer	000 ⇄ 255	0–100%
2	Dimmer Fine	000 ⇄ 255	0–100%
3	Red	000 ⇄ 255	0–100%
4	Red Fine	000 ⇄ 255	0–100%
5	Green	000 ⇄ 255	0–100%
6	Green Fine	000 ⇄ 255	0–100%
7	Blue	000 ⇄ 255	0–100%
8	Blue Fine	000 ⇄ 255	0–100%
9	Amber	000 ⇄ 255	0–100%
10	Amber Fine	000 ⇄ 255	0–100%
11	Lime	000 ⇄ 255	0–100%
12	Lime Fine	000 ⇄ 255	0–100%
13	Strobe	000 ⇄ 010	No function
		011 ⇄ 255	Strobe (slow to fast)
14	Virtual Color Wheel	000 ⇄ 255	See Virtual Color Wheel Chart
15	Color Temperature	000 ⇄ 255	See Preset Color Temperature Chart

13-Ch

Channel	Function	Value	Percent/Setting
1	Dimmer	000 ⇄ 255	0–100%
2	Dimmer Fine	000 ⇄ 255	0–100%
3	Red	000 ⇄ 255	0–100%
4	Red Fine	000 ⇄ 255	0–100%
5	Green	000 ⇄ 255	0–100%
6	Green Fine	000 ⇄ 255	0–100%
7	Blue	000 ⇄ 255	0–100%
8	Blue Fine	000 ⇄ 255	0–100%
9	Amber	000 ⇄ 255	0–100%
10	Amber Fine	000 ⇄ 255	0–100%
11	Lime	000 ⇄ 255	0–100%
12	Lime Fine	000 ⇄ 255	0–100%
13	Strobe	000 ⇄ 010	No function
		011 ⇄ 255	Strobe (slow to fast)

12-Ch

Channel	Function	Value	Percent/Setting
1	Dimmer	000 ⇄ 255	0–100%
2	Red	000 ⇄ 255	0–100%
3	Green	000 ⇄ 255	0–100%
4	Blue	000 ⇄ 255	0–100%
5	Amber	000 ⇄ 255	0–100%
6	Lime	000 ⇄ 255	0–100%
7	Strobe	000 ⇄ 010	No function
		011 ⇄ 255	Strobe (slow to fast)
8	Virtual Color Wheel	000 ⇄ 255	See Virtual Color Wheel Chart
9	Color Temperature	000 ⇄ 255	See Preset Color Temperature Chart
10	Auto Programs	000 ⇄ 010	No function
		011 ⇄ 060	Auto program 1
		061 ⇄ 110	Auto program 2
		111 ⇄ 160	Auto program 3
		161 ⇄ 210	Auto program 4
211 ⇄ 255	Auto program 5		
11	Auto Speed	000 ⇄ 255	0–100%
12	Dimmer Mode*	000 ⇄ 051	No function
		052 ⇄ 101	Linear dimmer
		102 ⇄ 152	Nonlinear dimming curve 1 (fastest)
		153 ⇄ 203	Nonlinear dimming curve 2
204 ⇄ 255	Nonlinear dimming curve 3 (slowest)		



*Hold desired Dimmer Mode value for 3 seconds, then release. This changes the Dimmer Mode setting in the menu.

10-Ch

Channel	Function	Value	Percent/Setting
1	Dimmer	000 ⇄ 255	0–100%
2	Dimmer Fine	000 ⇄ 255	0–100%
3	Red	000 ⇄ 255	0–100%
4	Green	000 ⇄ 255	0–100%
5	Blue	000 ⇄ 255	0–100%
6	Amber	000 ⇄ 255	0–100%
7	Lime	000 ⇄ 255	0–100%
8	Strobe	000 ⇄ 010 011 ⇄ 255	No function Strobe (slow to fast)
9	Virtual Color Wheel	000 ⇄ 255	See Virtual Color Wheel Chart
10	Color Temperature	000 ⇄ 255	See Preset Color Temperature Chart

7-Ch

Channel	Function	Value	Percent/Setting
1	Dimmer	000 ⇄ 255	0–100%
2	Red	000 ⇄ 255	0–100%
3	Green	000 ⇄ 255	0–100%
4	Blue	000 ⇄ 255	0–100%
5	Amber	000 ⇄ 255	0–100%
6	Lime	000 ⇄ 255	0–100%
7	Strobe	000 ⇄ 010 011 ⇄ 255	No function Strobe (slow to fast)

5-Ch

Channel	Function	Value	Percent/Setting
1	Red	000 ⇄ 255	0–100%
2	Green	000 ⇄ 255	0–100%
3	Blue	000 ⇄ 255	0–100%
4	Amber	000 ⇄ 255	0–100%
5	Lime	000 ⇄ 255	0–100%

3-Ch

Channel	Function	Value	Percent/Setting
1	Dimmer	000 ⇄ 255	0–100%
2	Virtual Color Wheel	000 ⇄ 255	See Virtual Color Wheel Chart
3	Color Temperature	000 ⇄ 255	See Preset Color Temperature Chart

1-Ch

Channel	Function	Value	Percent/Setting
1	Dimmer	000 ⇄ 255	0–100%

HSV

Channel	Function	Value	Percent/Setting
1	Hue	000 ⇄ 255	0–100%
2	Saturation	000 ⇄ 255	0–100%
3	Value	000 ⇄ 255	0–100%

Virtual Color Wheel

The Ovation P-56FC includes a feature called the Virtual Color Wheel (VCW). This feature is available as a standalone control mode for manual use and as a control channel in select DMX personalities. More than 30 pre-mixed colors, custom blended by our engineers, are available to call up for easier programming.

The DMX values used to mix these colors are provided below. You may adjust the overall intensity of the Ovation fixture in order to more closely replicate colors you are familiar with. A chart is available on our website www.chauvetprofessional.com to compare our pre-mixed colors with popular gel colors. This chart is for comparison purposes only and is not a representation that our pre-mixed colors match any of the gel colors listed.

Virtual Color Wheel Chart

DMX Channel Value	Display Readout	Red Value	Green Value	Blue Value	Amber Value	Lime Value
000 ⇔ 005	--	000	000	000	000	000
006 ⇔ 013	C3050 - Md Yellow	255	190	004	255	255
014 ⇔ 021	C3040 - Lt Yellow	255	111	011	255	255
022 ⇔ 028	C3240 - Amb Yellow	255	245	000	255	075
029 ⇔ 035	C2340 - VLt Amber	255	010	033	255	255
036 ⇔ 043	C2040 - Lt Amber	255	008	023	255	204
044 ⇔ 051	C2050 - Md Amber	255	000	003	255	172
052 ⇔ 059	C2060 - Dk Amber	255	000	003	255	110
060 ⇔ 067	C1050 - Lt Red	255	000	005	044	000
068 ⇔ 075	C1080 - Md Red	255	000	002	000	000
076 ⇔ 083	C1020 - NC Pink	255	105	074	255	255
084 ⇔ 091	C1030 - Md Pink	255	000	074	255	247
092 ⇔ 099	C1630 - Dk Pink	255	060	075	255	255
100 ⇔ 107	C1250 - Md Red Amber	255	000	010	255	008
108 ⇔ 115	C1060 - Dk Red Amber	255	000	012	096	000
116 ⇔ 121	C1650 - Magenta	255	000	062	255	082
122 ⇔ 130	C6170 - Dk Magenta	255	000	074	020	000
131 ⇔ 138	C6020 - Lt Lavender	255	255	118	255	199
139 ⇔ 146	C5030 - Lt Blue	000	255	171	040	255
147 ⇔ 154	C5020 - VLt Blue	000	255	180	224	255
155 ⇔ 162	C5430 - Lt Blue 2	000	255	148	000	226
163 ⇔ 170	C5070 - Blue	000	255	216	000	000
171 ⇔ 178	C5050 - Md Blue	000	255	212	000	113
179 ⇔ 186	C5060 - Dk Blue	000	242	255	000	053
187 ⇔ 194	C5690 - Indigo	026	039	255	000	000
195 ⇔ 202	C5080 - VDk Blue	000	200	255	000	000
203 ⇔ 210	C5081 - VDk Blue2	000	180	255	000	000
211 ⇔ 218	C4370 - Yel Green	000	255	005	000	045
219 ⇔ 226	C4070 - Green	000	255	025	000	147
227 ⇔ 234	C4550 - Turquoise	000	172	056	000	255
235 ⇔ 242	C4560 - Aqua	000	210	072	000	255
243 ⇔ 250	C4570 - Blue Green	000	255	030	000	005
251 ⇔ 255	--	000	000	000	000	000



Note: The colors above are simulated renditions of the color output produced as compared to other similar incandescent products. Chauvet makes no guarantee of the color output accuracy.

Preset Color Temperature Chart

DMX Channel Value	Display Readout	Red Value	Green Value	Blue Value	Amber Value	Lime Value
000 ⇄ 005	--	000	000	000	000	000
006 ⇄ 025	2800K	201	130	048	255	255
026 ⇄ 050	3000K	172	132	054	255	255
051 ⇄ 075	3200K	144	135	061	255	255
076 ⇄ 100	3500K	115	139	071	255	255
101 ⇄ 125	4000K	083	154	088	255	255
126 ⇄ 150	4500K	072	185	107	255	255
151 ⇄ 175	5000K	062	209	124	255	255
176 ⇄ 200	5600K	046	222	142	255	255
201 ⇄ 225	6000K	038	230	154	255	255
226 ⇄ 250	6500K	029	237	166	255	255
251 ⇄ 255	--	000	000	000	000	000



Note: The color temperatures above are simulated renditions of the color output produced as compared to a tungsten lamp at the specified color temperature. Chauvet makes no guarantee of the color output accuracy.

Configuration (Standalone)

Use standalone configuration to operate the product without a DMX controller.

Static Mode

The Static mode allows for an unchanging color without a DMX controller.

Virtual Color Wheel

1. Go to the **Virtual Color Wheel** main level.
2. Select **Virtual Color Wheel**.
3. Select the desired gel color (see [Virtual Color Wheel Chart](#)).
4. Select the desired output level (**000–255**).

Color Temperature

1. Go to the **Virtual Color Wheel** main level.
2. Select **Color Temperature**.
3. Select the desired color temperature (see [Preset Color Temperature Chart](#)).
4. Select the desired output level (**000–255**).

Manual Color Mixer

1. Go to the **Virtual Color Wheel** main level.
2. Select **Manual Color Mixer**.
3. Select the color to edit (**Red, Green, Blue, Amber, or Lime**).
4. Select the desired output level for that color (**000–255**).
5. Repeat steps 3 and 4 until product outputs as desired.

Auto Programs

Auto programs allow for dynamic blinder effects without a DMX controller.

1. Go to the **Auto Show** main level
2. Select the desired auto program (**Auto 1–5**).
3. Select the desired speed (**1–100**).



The auto programs cannot be edited.

OPERATION

Master/Slave

The Master/Slave mode allows a group of Ovation P-56FC products (the slaves) to simultaneously duplicate the output of another Ovation P-56FC (the master) without a DMX controller.

To set each of the slaves:

1. Go to the **Master/Slave** main level
2. Select **Slave**.

To set the master:

1. Go to the **Master/Slave** main level
2. Select **Master**.
3. Select a static setting.



- The master is the one that runs a program whether in Auto or Virtual Color Wheel mode.
- Do not connect a DMX controller to the products configured for Master/Slave operation. The DMX controller may interfere with signals from the master.
- The master should be the first product in the daisy chain.

Dimmer Profiles

This setting determines how fast the output of the Ovation P-56FC changes when you modify the output value. This setting provides four different options to simulate the dimming curve of an incandescent lighting product.

1. Go to the **Dimmer Mode** main level.
2. Select a dimmer curve (**Off**, **Dimmer 1**, **Dimmer 2**, or **Dimmer 3**).



- Off:** The output is proportional (linear) to the dimmer channel value.
- Dimmer 1-3:** The output follows the dimmer value based on the corresponding dimmer curve, **Dimmer 1** being the fastest.

White Balance

This setting determines the maximum output values for each color, which affects the appearance of a full output white.

1. Go to the White Balance main level.
2. Select **Off** (the product will use a default setting) or **Manual**.
3. For **Manual** mode, select the color value to edit (**Red**, **Green**, **Blue**, **Amber**, or **Lime**).
4. Set the maximum value for the selected color (**125–255**).
5. Repeat steps 3 and 4 until the product outputs as desired.

LED Frequency

This option changes the Pulse Width Modulation (PWM) frequency of the LEDs on the Ovation P-56FC.

1. Go to the **LED Frequency** main level.
2. Select PWM Frequency (**600Hz**, **1200Hz**, **2000Hz**, **4000Hz**, **6000Hz**, or **25Khz**).

Fan Mode

This setting determines how the fan speed on the Ovation P-56FC is set.

1. Go to the **Fan Mode** main level
2. Select **Auto** (fan speed will increase or decrease based on product temperature), **Off** (fan will stay off. Product output will decrease based on product temperature), **Silent** (fan will maintain a constant silent speed), or **On** (fan speed will always be at maximum).



WARNING: When operating in Fan Mode: **Off**, the fixture will become hotter to the touch than when using other fan modes. Use proper protective equipment to prevent burns. Keep a safe distance from flammable objects.



NOTICE: When operating in Fan Mode: **Off**, output of the fixture will be reduced and will not reach the same levels as when using other fan modes.

Back Light

This setting allows for selection of the amount of time the backlight on the Ovation P-56FC's display stays on after the last button is pressed on the control panel.

1. Go to the **Back Light** main level.
2. Select **Always On** (remains on), **10S** (10 seconds), **30S** (30 seconds), or **2MIN** (2 minutes).

System Information

This option displays the total number of hours the product has run, the installed software version, and the product's UID.

1. Go to the **Information** main level.
2. Select **Fixture Hours**, **Version**, or **UID**.

Factory Reset

This option restores the Ovation P-56FC to factory default settings.

1. Go to the **Reset Factory** main level.
2. Select **No** or **Yes**.

5. TECHNICAL INFORMATION

Product Maintenance

To maintain optimum performance and minimize wear, clean this product frequently. Usage and environment are contributing factors in determining the cleaning frequency.

Clean this product at least twice a month. Dust build-up reduces light output performance and can cause overheating. This can lead to reduced light source life and increased mechanical wear.

To clean the product:

1. Unplug the product from power.
2. Wait until the product is at room temperature.
3. Use a vacuum (or dry compressed air) and a soft brush to remove dust collected on the external vents.
4. Clean all transparent surfaces with a mild soap solution, ammonia-free glass cleaner, or isopropyl alcohol.
5. Apply the solution directly to a soft, lint-free cotton cloth or a lens-cleaning tissue.
6. Softly drag any dirt or grime to the outside of the transparent surface.
7. Gently polish the transparent surfaces until they are free of haze and lint.



Always dry the transparent surfaces carefully after cleaning them.

6. TECHNICAL SPECIFICATIONS

Dimensions and Weight

Length	Width	Height	Weight
12.48 in (317 mm)	12.83 in (326 mm)	14.0 in (363 mm)	12.2 lb (5.6 kg)

Note: Dimensions in inches rounded to the nearest hundredth.

Power

Power Supply Type	Range	Voltage Selection
Switching (internal)	100 to 240 VAC, 50/60 Hz	Auto-ranging

Parameter	120 V, 60 Hz	230 V, 50 Hz
Consumption	176 W	180 W
Operating current	1.448 A	0.777 A
Power-linking current (products)	13.6 A (9 products)	13.6 A (17 products)
Fuse	T 3.15 A, 250 V	T 3.15 A, 250 V

Power I/O	U.S./Canada	Worldwide
Power input connector	Neutrik® powerCON® A	Neutrik® powerCON® A
Power output connector	Neutrik® powerCON® B	Neutrik® powerCON® B
Power cord plug	Edison (U.S.)	Local Plug

Light Source

Type	Power	Lifespan
LED	3~5 W	50,000 hours

Color	Quantity	Current
Red	10	1 A
Green	10	1 A
Blue	8	1 A
Amber	8	1 A
Lime	12	1 A

Photometrics

Parameter	Medium Lens	Wide Lens
Beam angle	21°	52°
Field angle	35°	82°
Illuminance @ 5 m	1,350 lux	254 lux

Thermal

Maximum External Temperature	Cooling System
113 °F (45 °C)	Convection

DMX

I/O Connector	Channel Range
3- and 5-pin XLR	1, 3, 5, 7, 10, 12, 13, 15, or HSV

Ordering

Product Name	Item Code	UPC Number
Ovation P-56FC	03031500	781462218485



UL 1573
CSA C22.2 No. 166
E113093



Photometrics Chart

Distance	Medium		Light Source		Wide	
	21° Beam Diameter	35° Field Diameter	Footcandle	Footcandle	52° Beam Diameter	82° Field Diameter
15 ft	5.56 ft	9.46 ft	140		022	14.63 ft 26.08 ft
20 ft	7.41 ft	12.61 ft	079		012	19.51 ft 34.77 ft
30 ft	11.12 ft	18.92 ft	035		005	29.26 ft 52.16 ft
40 ft	14.83 ft	25.22 ft	020		003	39.02 ft 69.54 ft
50 ft	18.53 ft	31.53 ft	013		002	48.77 ft 86.93 ft
75 ft	27.80 ft	47.29 ft	006		001	73.16 ft 130.39 ft
100 ft	37.07 ft	63.06 ft	003		000	97.55 ft 173.86 ft
125 ft	46.33 ft	78.82 ft	002		000	121.93 ft 217.32 ft
150 ft	55.60 ft	94.59 ft	001		000	146.32 ft 260.79 ft

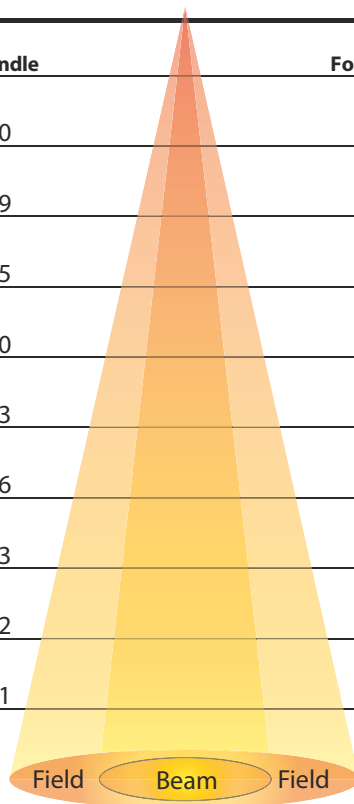

Distance	Medium		Light Source		Wide	
	21° Beam Diameter	35° Field Diameter	Lux	Lux	52° Beam Diameter	82° Field Diameter
1 m	0.37 m	0.63 m	31,600		4,850	0.98 m 1.74 m
2 m	0.74 m	1.26 m	7,900		1,213	1.95 m 3.48 m
5 m	1.85 m	3.15 m	1,264		194	4.88 m 8.69 m
8 m	2.97 m	5.04 m	494		076	7.80 m 13.91 m
10 m	3.71 m	6.31 m	316		049	9.75 m 17.39 m
15 m	5.56 m	9.46 m	140		022	14.63 m 26.08 m
20 m	7.41 m	12.61 m	079		012	19.51 m 34.77 m
25 m	9.27 m	15.76 m	051		008	24.39 m 43.46 m
30 m	11.12 m	18.92 m	035		005	29.26 m 52.16 m

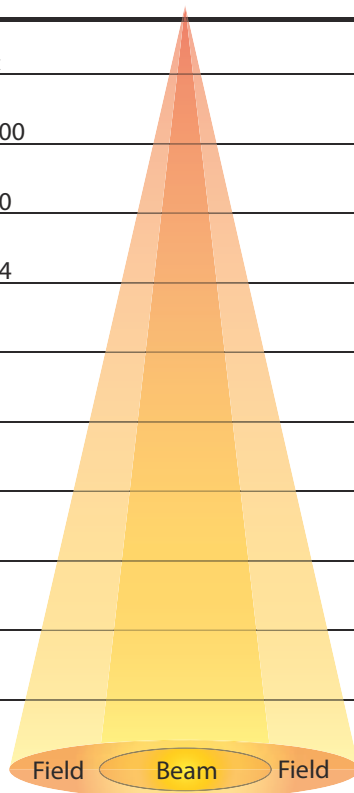

RETURNS

Send the product prepaid, in the original box, and with the original packing and accessories. Chauvet will not issue call tags.

Call Chauvet and request a Return Merchandise Authorization (RMA) number before shipping the product. Be prepared to provide the model number, serial number, and a brief description of the cause(s) for the return.

Clearly label the package with an RMA number. Chauvet will refuse any product returned without an RMA number.



Write the RMA number on a properly affixed label. DO NOT write the RMA number directly on the box.

Once you have the RMA number, provide the following information on a piece of paper and place it inside the box:

- Your name
- Your address
- Your phone number
- RMA number
- A brief description of the problem

Be sure to pack the product properly. Any shipping damage resulting from inadequate packaging will be your responsibility. FedEx packing or double-boxing are recommended.



Chauvet reserves the right to use its own discretion to repair or replace returned product(s).

CONTACT US

General Information	Technical Support
Chauvet World Headquarters	
Address: 5200 NW 108th Ave. Sunrise, FL 33351 Voice: (954) 577-4455 Fax: (954) 929-5560 Toll Free: (800) 762-1084	Voice: (844) 393-7575 Fax: (954) 756-8015 Email: chauvetcs@chauvetlighting.com Website: www.chauvetprofessional.com
Chauvet Europe Ltd	
Address: Unit 1C Brookhill Road Industrial Estate Pinxton, Nottingham, UK NG16 6NT Voice: +44 (0) 1773 511115 Fax: +44 (0) 1773 511110	Email: UKtech@chauvetlighting.eu Website: www.chauvetprofessional.eu
Chauvet Europe BVBA	
Address: Stokstraat 18 9770 Kruishoutem Belgium Voice: +32 9 388 93 97	Email: BNLtech@chauvetlighting.eu Website: www.chauvetprofessional.eu
Chauvet France	
Address: 3, Rue Ampère 91380 Chilly-Mazarin France Voice: +33 1 78 85 33 59	Email: FRtech@chauvetlighting.fr Website: www.chauvetprofessional.eu
Chauvet Germany	
Address: Bruno-Bürgel-Str. 11 28759 Bremen Germany Voice: +49 421 62 60 20	Email: DEtech@chauvetlighting.de Website: www.chauvetprofessional.eu
Chauvet Mexico	
Address: Av. de las Partidas 34 - 3B (Entrance by Calle 2) Zona Industrial Lerma Lerma, Edo. de México, CP 52000 Voice: +52 (728) 690-2010	Email: servicio@chauvet.com.mx Website: www.chauvetprofessional.mx

Visit the applicable website above to verify our contact information and instructions to request support. Outside the U.S., United Kingdom, Ireland, Mexico, France, Germany, or Benelux, contact the dealer of record.