

# Hub

**CREWCOM**  
BY PLIANT

OPERATING MANUAL

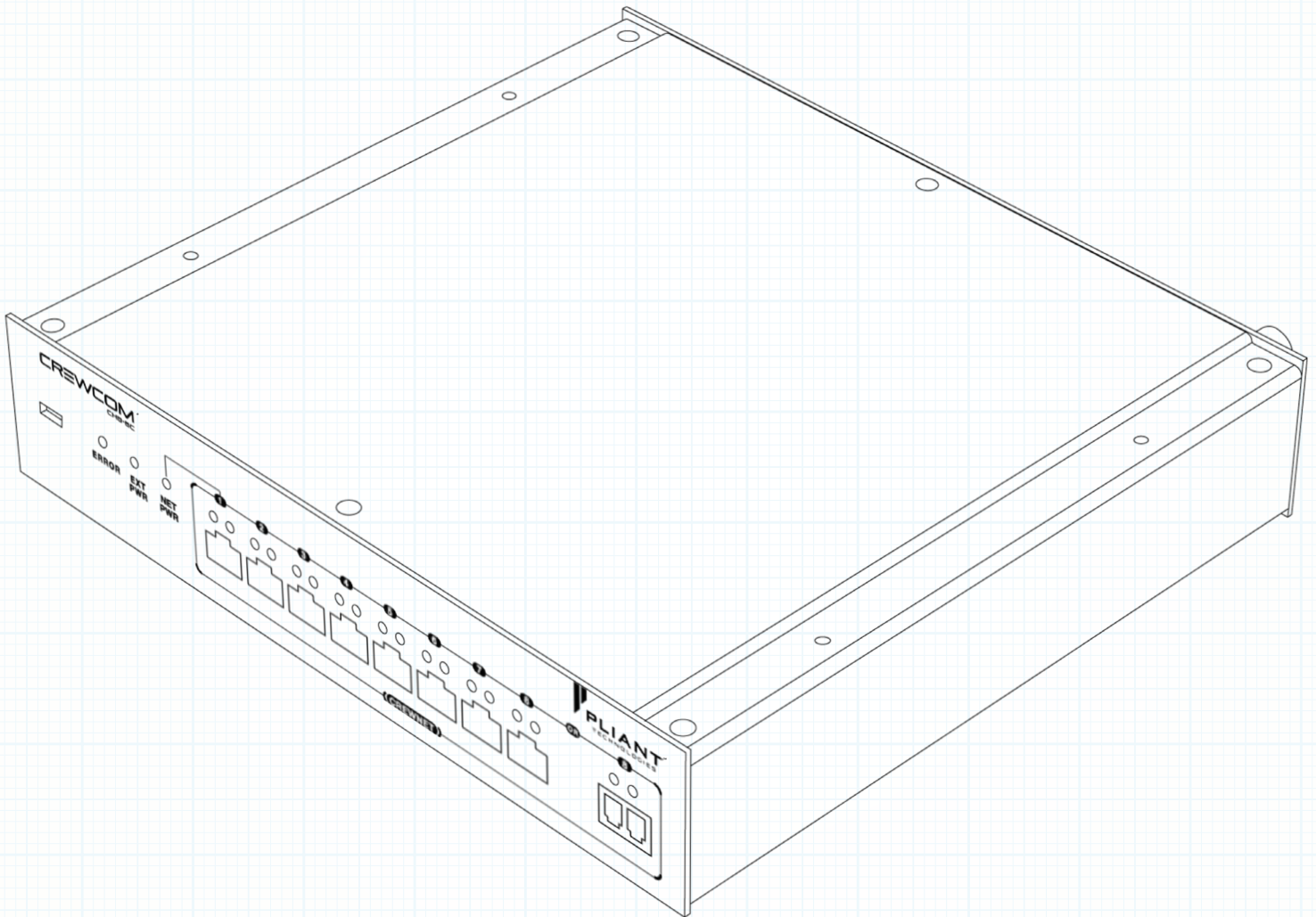

# Thank You

We at Pliant® Technologies want to thank you for purchasing CrewCom®. Pliant brings our experience, expertise, and commitment to quality technology with the new CrewCom System. In order to get the most out of your new CrewCom product, please take a few moments to read this manual completely so that you better understand the operation of this product. For questions not addressed in this manual, feel free to review the additional support documentation provided on our website or contact Pliant's Customer Support Department:

Pliant Technologies, LLC  
205 Technology Parkway  
Auburn, AL 36830 USA  
[www.plianttechnologies.com](http://www.plianttechnologies.com)  
Phone: +1.334.321.1160  
Toll-Free: 1.844.475.4268 or 1.844.4PLIANT  
Fax: +1.334.321.1162

Copyright © 2018–2019 Pliant Technologies, LLC. All rights reserved. The Pliant®, CrewCom®, and CrewNet™ word marks and the Pliant "P" logo are trademarks of Pliant Technologies, LLC. Any and all other trademark references within this document are property of their respective owners.

## Model Information

This document applies to model CHB-8C, CHB-8C-02, and CHB-8F.  
Document Reference: 2019.11 D0000217\_G

# Table of Contents

Safety Information .....	1
Safe Operation Recommendations .....	1
Safe Installation Recommendations .....	1
Power Information .....	2
Introduction .....	3
What's in the box? .....	3
Additional Items Required .....	3
Optional Item(s) .....	3
Firmware Release Notes .....	3
CrewCom Overview .....	3
CrewCom Configuration File Overview.....	5
About Network Power .....	5
Product Overview .....	6
CrewCom Copper Hub .....	6
CrewCom Fiber Hub.....	8
Setup and Installation .....	9
Determining the Device Location .....	9
Connecting to CrewNet.....	9
Powering the Device .....	10
Activating the Device .....	10
Operation.....	11
Understanding the Hub LEDs.....	11
Product Specifications .....	12
Product Support .....	13
Returning Equipment for Repair or Maintenance .....	13
Maintenance and Storage .....	14
Cleaning.....	14
Temperature and Humidity .....	14
License Information .....	15
CrewCom Compliance Numbers .....	15
Warranty Information .....	16
Limited Warranty.....	16
Parts Limited Warranty .....	16
Glossary .....	17
Index .....	18

# Safety Information

The following section details important safety information related to the ownership and operation of the CrewCom Hub.



**WARNING:** Indicates a situation, which, when not avoided, has the potential to result in death or severe injury.



**CAUTION:** Indicates a situation, which, when not avoided, results or has the potential to result in minor injury or product failure or damage.

1. Read these instructions.
2. Follow all instructions.
3. Heed all warnings.

## Safe Operation Recommendations

- Install and operate in accordance with manufacturer's instructions.
- Do not submerge the Hub in water.
- Do not set food, water, or other beverage containers on or near the unit.
- Do not place unit in areas where it will be exposed to weather.
- Ensure the device's cord remain free from areas of foot traffic. Do not allow cords to become crimped, twisted, or frayed.
- Clean only with a dry cloth. Do not spray household cleaners or water onto the cloth. Never spray household cleaners or water onto any part the Hub.
- Use only attachments/accessories that are specifically made for or certified by Pliant Technologies with the Hub. Any attempt to modify ports in order to use cables or wires that are not manufactured specifically for or certified for use on this system will void the product warranty.
- Unplug the Hub during periods of inclement weather and after use.
- **Refer all Hub service to qualified Pliant Technologies service personnel.** There are no user-serviceable parts inside the Hub. Opening the product may expose dangerous electrical components, which will result in product failure. Any attempt to self-service or self-repair the unit will void the product warranty.
- Service is required if the Hub receives any type of damage to any of its parts or if it does not operate normally. For example, if water or any other type of liquid has been spilled on the Hub or if it has been exposed to rain or moisture, then service is necessary. Service is also required if debris or other objects have fallen into the unit or if it has been dropped.

## Safe Installation Recommendations

- **Elevated Operating Ambient Temperature** - If installed in a closed or multi-unit rack assembly, the operating ambient temperature of the rack environment may be greater than room ambient. Therefore, consideration should be given to installing the equipment in an environment compatible with the maximum ambient temperature (T<sub>ma</sub>) specified on page 12.
- **Reduced Air Flow** - Installation of the equipment in a rack should be such that the amount of air flow required for safe operation of the equipment is not compromised.
- **Mechanical Loading** - Mounting of the equipment in the rack should be such that a hazardous condition is not achieved due to uneven mechanical loading.

- **Circuit Overloading** - Consideration should be given to the connection of the equipment to the supply circuit and the effect that overloading of the circuits might have on overcurrent protection and supply wiring. Appropriate consideration of equipment nameplate ratings should be used when addressing this concern.
- **Reliable Earthing** - Reliable earthing of rack-mounted equipment should be maintained. Particular attention should be given to supply connections other than direct connections to the branch circuit (e.g., use of power strips).

## Power Information



**WARNING** – DANGER! Users should exercise extreme care when working with electricity. Additional care should be used when working with electricity outdoors in inclement weather. When working outdoors or near water, always connect the system into a ground-fault interrupting circuit.

### AC Power Connection Safety

- When using local power to power the Hub, always connect the power cord to the CrewCom Hub's external power supply before connecting to the outlet.
- CrewCom Hubs may be powered by an external power supply. The cord to connect the external power supply to the mains supply must conform to the following specifications:
  - » The mains power cord shall have an IEC C13 connector at one end and a mains power plug at the opposite end.
  - » An IEC C13 plug has three pins. The center pin carries the earth/ground. The remaining two pins carry neutral and live circuits.
  - » The conductors of the mains cords shall have adequate cross-sectional area for rated current consumption of the equipment.
  - » The mains plug that connects to the mains supply must be approved for use in the country in which the equipment will be used.
  - » The mains power cord must be an IEC mains 3-Wire grounding power cord complying with standard IEC60320; IEC320/C13.
  - » Mains power cords used in the U.S. must also comply with standard UL817.

# Introduction

## What's in the box?

- CrewCom Copper Hub (1) OR CrewCom Fiber Hub (1)
- USB A to Micro B Cable
- Cat 5e Cable, 6 ft. (1.8 m)
- Fiber Cable, 6 ft. (1.8 m) (Fiber Hub Only)
- Rubber Feet
- 48VDC External Power Supply\*
- Product Overview Guide
- Warranty Extension Registration Card\*\*

**\*Note:** Power Supplies vary by CrewCom Hub model, and they are not interchangeable. Always ensure your Hub uses a compatible power supply: PPS-48V-02 with CHB-8C-02 and CHB-8F; PPS-48V with CHB-8C.

**\*\*Note:** A one year product warranty is standard with CrewCom products. Follow the product registration instructions on the Warranty Extension Registration Card and visit [www.plianttechnologies.com/customer/account/login](http://www.plianttechnologies.com/customer/account/login) to extend your product warranty to two years. See page 16 for more information about Pliant warranties.

## Additional Items Required

In addition to your Copper or Fiber Hub, at least one of each of the devices listed below is required to complete your CrewCom System (sold separately with included components):

- Control Unit (includes AC Power Cord; USB A to Micro B Cable; Cat 5e cable, 15 ft. (4.6 m); and USB Flash Drive)
- Radio Transceiver (includes USB A to Micro B cable; Cat 5e cable, 15 ft. (4.6 m); Mounting Hardware/Bracket; and 2 Omni-Directional Antennas)
- Radio Pack (includes Lithium-Polymer Rechargeable Battery, USB A to Micro B Cable, Multi Blade Worldwide Battery, and Charger/Power Supply)
- Headset

## Optional Item(s)

- CrewCom-Hub-compatible rack ears (PAC-RMK-S and PAC-RMK-D) are available for purchase separately if needed.

## Firmware Release Notes

Find the latest CrewCom firmware release notes on the Pliant Technologies website at [www.plianttechnologies.com/media/resources/releasenotes/crewcom\\_release\\_notes.pdf](http://www.plianttechnologies.com/media/resources/releasenotes/crewcom_release_notes.pdf)

Download the latest firmware release from <https://plianttechnologies.com/downloads>.

## CrewCom Overview

CrewCom is a versatile yet straightforward communications solution built on an intelligent wireless and wired network-based distributed system architecture. Innovative technologies have been specifically developed to facilitate intercom system growth and effortless adaptation, along with unparalleled digital wireless reliability for consistent operation, even in the most demanding production environments.

## ***Decentralized Network Architecture***

The CrewCom system utilizes a proprietary network backbone, known as CrewNet™, to coordinate and transport all system timing, audio, signaling, and controls. This efficient, decentralized resource network delivers increased flexibility over that of traditional technologies, using a distributed network-to-device intelligence within a modular building block structure. System components can easily be placed where they are needed or scaled to facilitate system growth, reconfiguration, and effortless adaptation to changing environments. For increased infrastructure flexibility, the CrewNet network is capable of operating over standard Cat 5e (or greater) and/or Single Mode Fiber (SMF) lines.

## ***Flexible RF Platform***

CrewCom's RF platform is vast and flexible to meet the needs of virtually any wireless communication challenge facing production and entertainment professionals worldwide. Each CrewCom wireless product is available in the 2.4GHz and 900MHz (North America, Australia, and New Zealand only) ISM bands and any combination of these frequency ranges may be simultaneously used on the same CrewCom system. CrewCom makes it easy to operate in challenging RF environments by combining support for multiple simultaneous frequency bands, while also allowing for simple system setup without the need for an RF engineer.

In addition, a more robust RF link enhances RF range and reliability through a newly developed dual carrier double-send transmission scheme that minimizes the adverse effects of inter-symbol interference. This innovation allows increased useful RF range and improved performance, especially in large, reflective environments.

## ***Intuitive User Experience***

CrewCom's family of products is designed around a system architecture that offers a high density of users with a more manageable infrastructure and lower cost per user than typically found in large-scale wireless installations. The CrewCom system not only consists of a range of wired and wireless hardware products but also incorporates an intuitive software application, known as CrewWare, working together with the system hardware to enhance the experience of system administrators, designers, integrators, and users. Each device's user interface allows a quick learning curve with high functionality, and its ease of use is consistent across all frequency bands, types of users, and applications.

## ***CrewCom Devices***

The following is a list of available CrewCom devices. For more information on each of these products and their configuration capabilities, visit our website at: [www.plianttechnologies.com](http://www.plianttechnologies.com)

- **Control Unit (CU)** – the 1RU foundational element of the CrewCom system that establishes the CrewNet-based infrastructure while also providing external connections to common established intercom systems. Unlike traditional BaseStations, the CU contains no radio and is frequency agnostic, which sets the groundwork for a multi-frequency capable system. For maximum flexibility, any CU can access, control, and monitor any active device across CrewNet. The CU is available in a "CCU-22" or "CCU-44" model, which simultaneously support up to (2) 2-Wire and (2) 4-Wire or (4) 2-Wire and (4) 4-Wire intercom connections, respectively.
- **Radio Transceiver (RT)** – a CrewCom radio device that houses a radio (2.4GHz or 900MHz) and its corresponding antennas, enabling RF communications to CrewCom Radio Packs. Using the CrewNet network as the system's backbone, RTs can be positioned throughout a wide coverage area by being linked back to a Control Unit either directly or through a Hub(s). Connectivity is accomplished using either Cat 5e (or greater) or Single Mode Fiber (SMF).
- **Radio Pack (RP)** – the direct portable wireless communication device connecting individual CrewCom users to the CrewCom system. Each RP provides full duplex audio communications and, through customized function buttons, GPO control and event logging. The RP requires a connected headset and access to a Radio Transceiver on the CrewCom system. Devices are available in 2.4GHz and 900MHz bands as well as two and four volume/talk button configurations.
- **Copper Hub** – a CrewNet-based device with eight ports to allow extended interconnection for a variety of CrewCom hardware. Ports one through seven are copper (RJ-45, Cat 5e, or greater); port eight can be either an additional copper port or a duplex LC Single Mode Fiber port, but only one may be used at a time. The Hub provides for extensive system expansion and flexibility.

- **Fiber Hub** – a CrewNet-based device with eight ports to allow extended interconnection for a variety of CrewCom hardware. Ports two through eight are duplex LC Single Mode Fiber ports; port one can be either an additional fiber port or a copper port (RJ-45, Cat 5e, or greater), but only one may be used at a time. The Hub provides for extensive system expansion and flexibility.

## CrewCom Configuration File Overview

The CrewCom system operates using a CrewCom Configuration File (CCF) to coordinate the processes and data that make up the system's operation. A default CCF is available for your CrewCom system out of the box to provide your initial settings. You can use CrewWare to customize your configuration to meet your specific needs beyond the default settings. The CCF stores the settings for your Conferences and Profiles, intercom settings, and connection information for your 2-Wire, 4-Wire, and CrewCom devices.

Conferences and Profiles work together to create channels of communication between CrewCom users. They are defined for each user, stored in the CCF, and available each time you set up. For more information about Conferences and Profiles, continue reading the following sections for their definition.

### About Conferences

A CrewCom Conference is an administrator-defined grouping of audio entities (inputs such as Radio Packs, wired intercom ports, etc.). Audio outputs are then created dynamically by mixing one or more audio entities and routing them to Conference subscribers accordingly. This method of subscription-based audio using Conferences is very powerful. Point-to-point associations may also be easily constructed using this method. Each association requires a separate, unique Conference. Conferences in CrewCom are full duplex (i.e. bidirectional) and there can be a maximum of 64.

Default Conferences are included as part of a system's default configuration. New Conferences can be created using CrewWare.

### About Profiles

Each CrewCom Radio Pack has a Profile that contains a variety of system settings that are defined as either global profile settings or user settings. A Radio Pack Profile assigns functionality to an RP's local controls, knobs, and buttons (including Conference assignments), and allows customization for user preferences and roaming

- **Global Profile Settings** - These settings are part of the CrewCom Configuration File and are usually assigned by a system administrator through customization in CrewWare during setup. Find a full list of the global profile settings available for each Radio Pack in the CrewWare Operating Manual or the Radio Pack Operating Manual.
- **User Settings** - A user setting is one that is classified as being adjustable by the Radio Pack user and is limited to local device settings that do not alter the CrewCom Configuration File. The Profile can be used to determine these settings, but they can also be customized directly from a Radio Pack after a Profile is loaded.

## About Network Power

Power-Over-CrewNet (PoC) is a proprietary network protocol that provides operating voltage and current to CrewNet-compatible devices connected to the Control Unit via RJ-45 connections (Cat-5e or greater). Control Units must receive AC power via the supplied power cord in order to operate and provide necessary PoC to connected CrewNet-compatible devices.

To ensure best performance, especially with larger CrewCom configurations and longer cable lengths, Pliant recommends utilizing the supplied 48VDC power supply to locally power each Hub. However, powering a Hub and the devices connected to it via PoC may be advantageous in some smaller configurations. **Fiber connections will not transfer power to the Hub.** The supplied 48VDC Power Supply (PPS-48V-02 with CHB-8C-02 and CHB-8F, PPS-48V with CHB-8C) must be used in conjunction with a fiber connection in order for the Hub to operate.

PoC can be supplied to devices downstream from a locally powered CrewCom Copper Hub. Under optimal conditions, connected CrewCom devices may be powered from a locally powered Hub; however, this number can vary greatly depending on the line lengths and the number and configuration of those connected devices.



# Product Overview

The CrewCom Hub operates on CrewNet and allows a variety of CrewCom devices to be interconnected. The Hub consists of CrewNet ports that enable users to add more CrewCom devices, such as Radio Transceivers, in order to extend the connection of their CrewCom system.

The Hub is a 1RU half-rack-mount capable device. A maximum of 32 hubs (within up to four Hub layers) can be on a CrewCom system. See "About Hub Layers" on page 10 for more information.

There are two types of CrewCom Hubs: the Copper Hub and the Fiber Hub.

## CrewCom Copper Hub

The Copper Hub (CHB-8C-02) has eight ports for copper connections and one fiber-optic port.

Port 8 is an "either/or" connection. The eighth copper port and the fiber port cannot operate simultaneously; the user must choose one or the other. See "Connecting to CrewNet" on page 9 of this manual for more information about choosing between copper and fiber.

**Note:** The front and rear Copper Hub labels and LEDs are identical and display identical alerts. This allows for both front and/or rear face mounting. See Figure 1:

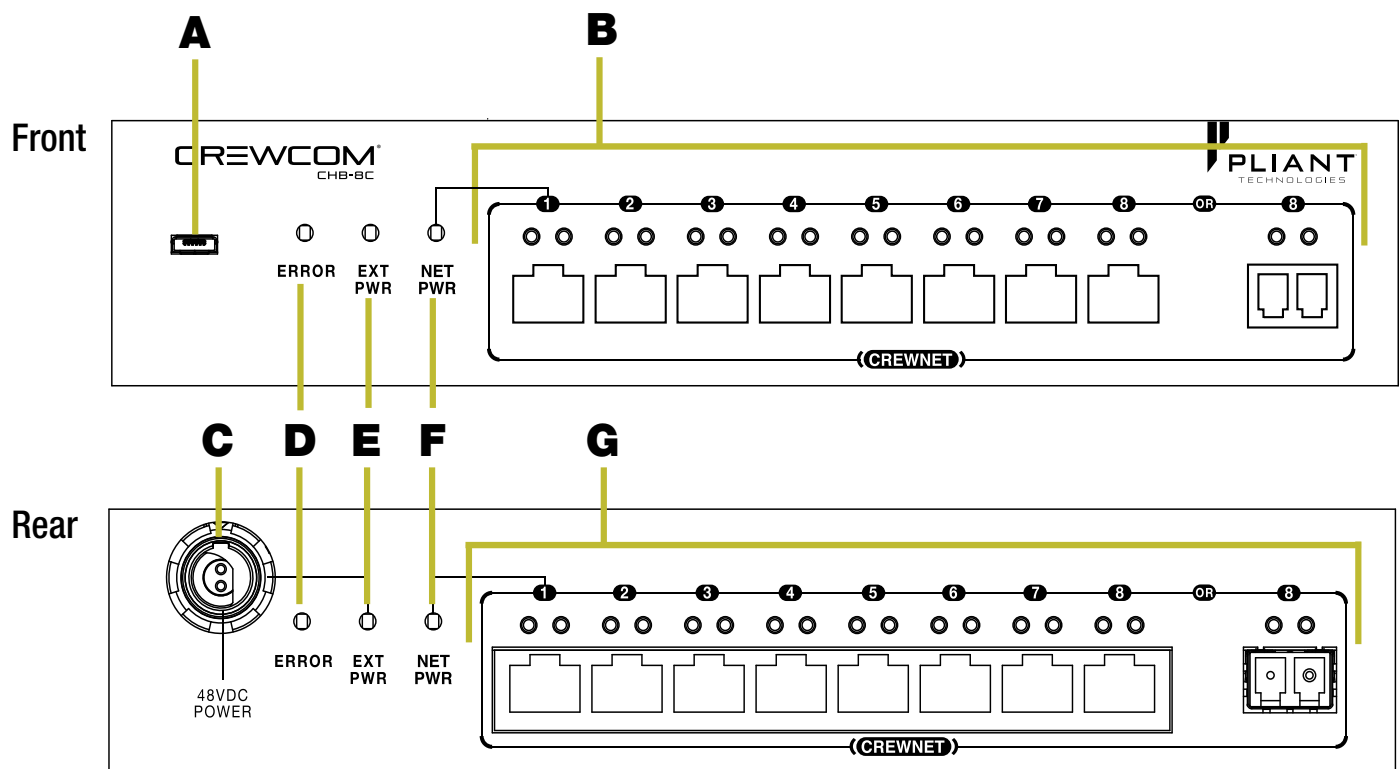

Figure 1: Copper Hub Front and Rear View

**(A) USB Connection**

Connects Hub to a computer to update firmware. See the *CrewWare Manual* for more information on updating firmware.

**(B) CREWNET Port Labels and Status LEDs for Ports 1–8**

The front and rear Copper Hub labels and LEDs are identical and display identical alerts. The port status LEDs indicate the CrewNet connection status. See the Operation section on page 11 for more LED information.

**(C) 48VDC Power Connection**

Power connection for the Pliant 48VDC Power Supply (PPS-48V-02 included with CHB-8C-02 and CHB-8F, PPS-48V included with CHB-8C PPS-48V-02), which allows the Hub to receive external (local) power.

To ensure best performance, especially with larger CrewCom configurations and longer cable lengths, Pliant recommends utilizing the supplied 48VDC power supply to locally power each Hub. However, powering a Hub and the devices connected to it via PoC may be advantageous in some smaller configurations.

**(D) ERROR LED**

Device error status indicator. This LED function is currently not available. See the Operation section on page 11 of this manual for more LED information.

**(E) External (Local) Power (EXT PWR) LED**

Indicates that external (local) power is being provided via a Pliant 48VDC Power Supply. See the Operation section on page 11 of this manual for more LED information.

**(F) Network Power (NET PWR) LED**

Indicates the Hub is receiving PoC via Port 1. The LED indicates the presence and strength of this PoC.

The Hub must be connected to Port 1 via a Cat 5e (or greater) copper cable in order for it to receive PoC. If PoC is not used, the Hub must be powered externally by a Pliant 48VDC Power Supply.

**(G) CREWNET Ports 1–8 and Status LEDs**

The CrewNet ports allow the Hub to connect to the CrewCom Control Unit and Radio Transceivers, supporting a proprietary network design where all devices are part of a CrewCom Configuration File that shares data, timing synchronization, and audio. Ports 1 through 7 are copper (RJ-45, Cat 5e or greater); Port 8 can be either the last copper port or the separate duplex LC Single Mode Fiber port, and only one may be used at a time.

**Note:** Port 1 cannot power devices. It can only accept power, and this power is indicated with the NET PWR LED. Since Port 1 cannot source power to downstream devices, even if the Hub is locally powered, any device connected to this port will require its own local power supply. To ensure best performance, especially with larger CrewCom configurations and longer cable lengths, Pliant recommends utilizing the supplied 48VDC power supply to locally power each Hub. However, powering a Hub and the devices connected to it via PoC may be advantageous in some smaller configurations.

Each port's status LEDs indicate the status of the CrewNet connection. See the Operation section on page 11 of this manual for more LED information.

## CrewCom Fiber Hub

The Fiber Hub (CHB-8F) functions identically to the Copper Hub, except it has eight ports for fiber optic connections and one copper port.

Port 1 is an “either/or” connection, and use of Port 1 is required for downstream operation of ports 2–8. The first fiber port and the copper port cannot operate simultaneously; the user must choose one or the other. See “Connecting to CrewNet” on page 9 of this manual for more information about choosing between copper and fiber.

**Note:** The front and rear Fiber Hub labels and LEDs are identical and display identical alerts. See Figure 2:

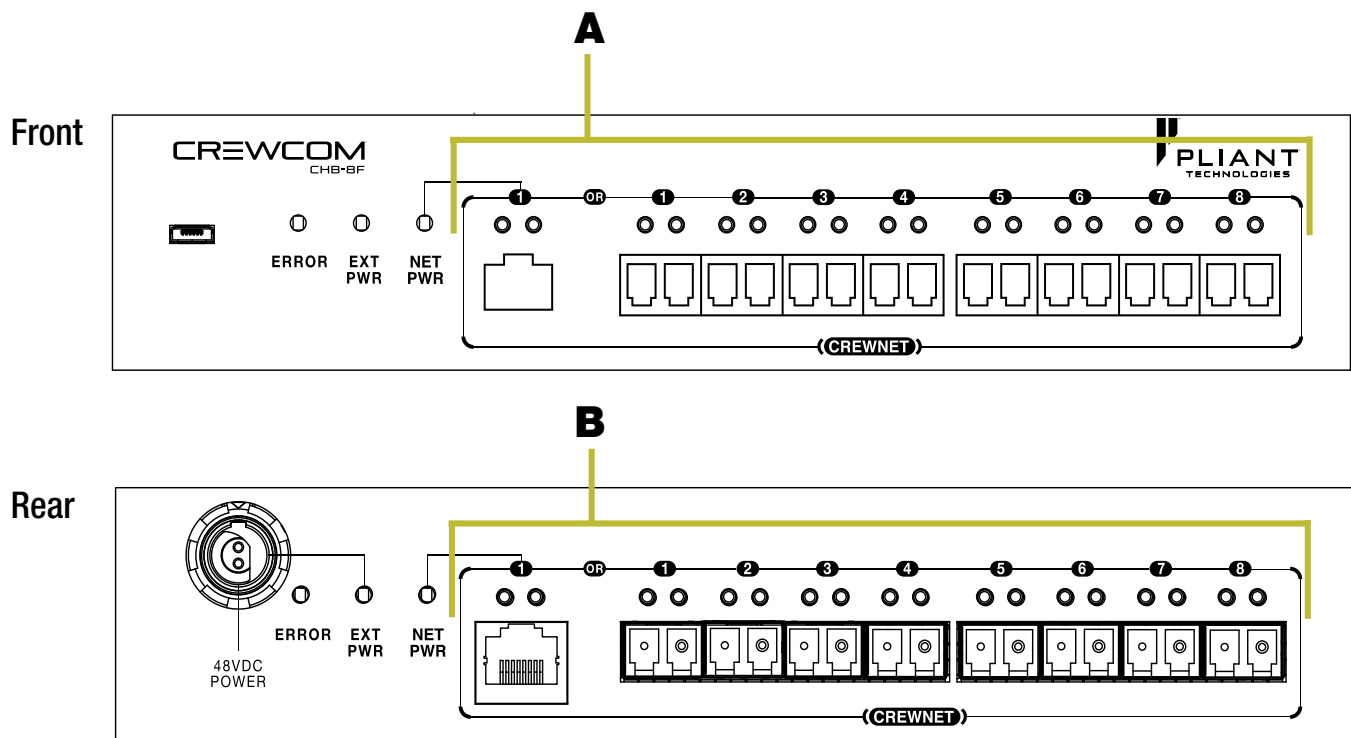

Figure 2: Fiber Hub Front and Rear View

### (A) CREWNET Port Labels and Status LEDs for Ports 1–8

The front and rear Fiber Hub labels and LEDs are identical and display identical alerts. The port status LEDs indicate the CrewNet connection status. See the Operation section on page 11 for more information.

### (B) CREWNET Ports 1–8 and Status LEDs

The CrewNet ports allow the Hub to connect to the CrewCom Control Unit and Radio Transceivers, supporting a proprietary network design where all devices are part of a CrewCom Configuration File that shares data, timing synchronization, and audio. Ports 2 through 8 are duplex LC Single Mode Fiber ports; Port 1 can be either the first fiber port or the copper (RJ-45, Cat 5e or greater) port, and only one may be used at a time.

**Note:** Port 1 (copper only) is only capable of PoC input, and Port 1 cannot supply PoC output. Either copper or fiber use of Port 1 is required for downstream operation of ports 2–8.

Each port's status LEDs indicate the status of the CrewNet connection. See the Operation section on page 11 of this manual for more LED information.

# Setup and Installation

## Determining the Device Location

Determine a location for your CrewCom Hub.

- If rack-mounting, secure using its rack-mounting hardware. They can be mounted either single or two side by side. (Mounting hardware, PAC-RMK-S and PAC-RMK-D, sold separately).
- Or place the device on a clean, flat surface. For your convenience, stick-on rubber feet are included with the Hub.

## Connecting to CrewNet

After securely placing the Hub, connect it to other CrewCom devices via its available CrewNet ports. Device port connections must match the CCF in order to operate. Pliant recommends making all cable connections between devices prior to powering on the system. Adding and removing devices in live mode (often referred to as "hot-plugging" or "hot-swapping") may cause system errors to occur.

- **RJ-45 Ports** – For an RJ-45 copper CrewNet port, use the supplied 6.6 ft. (2 m) Cat 5e cable, or your own Cat 5e (or greater) cable (up to 330 ft. (100 m) in length). Any CrewCom device connected to CrewNet via a Cat 5e (or greater) cable can receive Power-over-CrewNet (PoC) via the CrewNet port. In some situations, there may be too many connected devices or the cable lengths may be too long for the PoC to adequately power all devices, and this will be indicated with the NET PWR LED lighting red. To ensure best performance, especially with larger CrewCom configurations and longer cable lengths, Pliant recommends utilizing the supplied 48VDC power supply to locally power each Hub. However, powering a Copper Hub and the devices connected to it via PoC may be advantageous in some smaller configurations.
- **Fiber (Optical) Ports** - For a fiber CrewNet port, a Single Mode Fiber cable (duplex LC connector) will be required (up to 32,800 ft. (10 km) in length). Any CrewCom device connected to CrewNet via fiber port must receive power via a Pliant 48VDC power supply (PPS-48V-02 included with CHB-8C-02 and CHB-8F, PPS-48V included with CHB-8C; power supply sold separately with all other devices).

## About Hub Layers

Any additional Hub cascaded from a previous Hub is considered a new Hub layer. Cascading can be direct from a previous Hub or through another CrewNet device. (See a diagram of some possible Hub configurations in Figure 3.) A helpful way of determining Hub layers is to count how many Hubs you pass through to reach the Master CU, including the starting Hub.

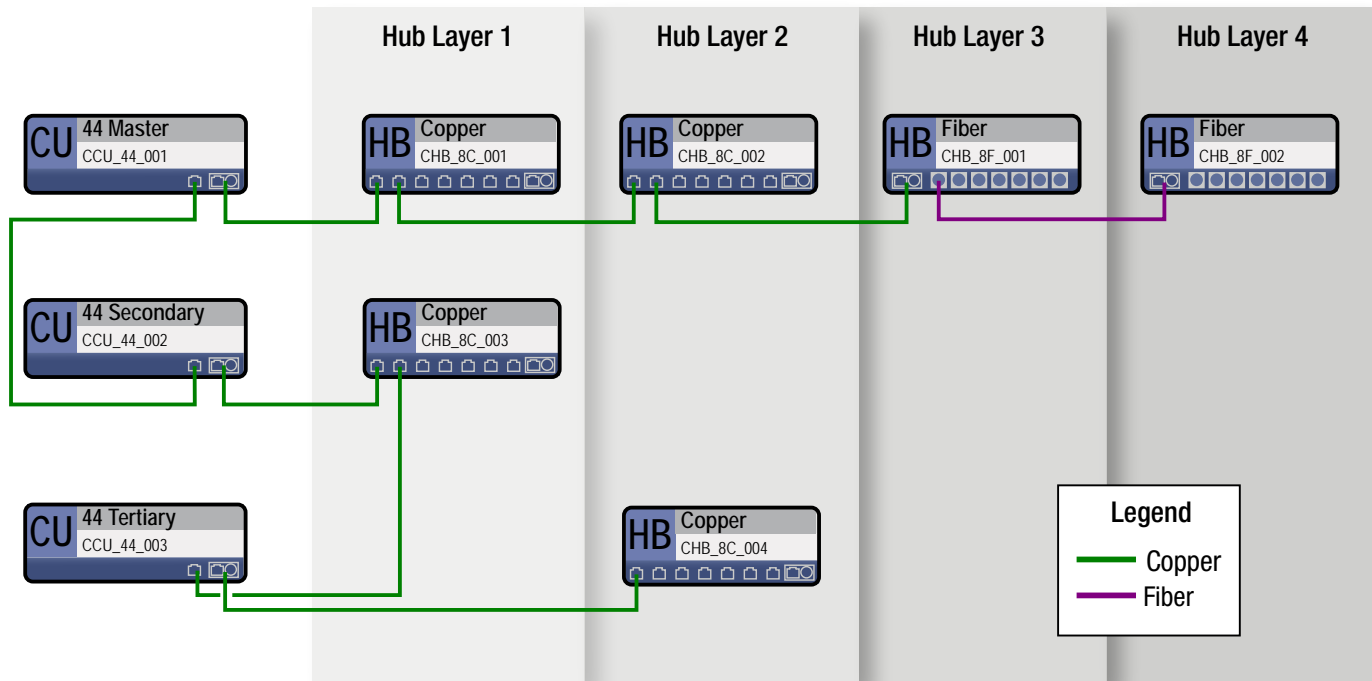

Figure 3: Hub Layer Examples

## Powering the Device

After connecting your CrewCom devices, power everything on and verify that your Hub is receiving power by checking that the applicable Power LED is green. PoC can be supplied to devices downstream from a locally powered CrewCom Copper Hub. Under optimal conditions, 7–9 connected CrewCom devices may be powered from a locally powered Copper Hub; however, this number varies greatly depending on the line lengths and the number and configuration of those connected devices.

Once the CU is powered on, you can tell that a configuration error has occurred with the Hub if a connected RT's TX LED is not lit and its RPs do not log in. The configuration error may be present in the RT or other device upstream. If you are connected to CrewWare, it will alert you of any firmware or configuration errors needing resolution. If a device does not have compatible firmware, follow the instructions provided in the *CrewWare Manual* to update to the correct version.

**Note:** See the *Connecting to CrewNet* section above for more information on how power is distributed for all connected CrewCom devices.

## Activating the Device

If you need to add additional CrewCom devices (e.g., a Hub, RT, or additional Control Units) after you've applied your CrewCom Configuration File, you'll need to power down your system and add the devices while powered down and offline.

Connect the additional CrewCom device(s) to CrewNet via an available CrewNet RJ-45 Copper or duplex LC Fiber port. Add the device(s) to your system diagram in CrewWare, then save the Configuration File change and apply the new Configuration File to your system.

Advanced device settings and system configuration and customization can be done via CrewWare. Refer to the separate *CrewWare Operating Manual* for more information on this process.

# Operation

## Understanding the Hub LEDs

Each LED on the Front and Rear of the Hub display identical connection and power status information, allowing the user to monitor the device easily from both a free-standing or rack mount configuration.

**Table 1: Hub LED Descriptions**

Connection/LED	Description	
<b>ERROR LED</b>	This LED function is currently not available.	
<b>EXT PWR LED</b>	<b>Green</b> – External (local) power is present. <b>Off</b> – No external (local) power is present.	
<b>NET PWR LED</b>	<b>Green</b> – Power-over-CrewNet (PoC) is adequate for operation with current connections. <b>Amber</b> – PoC is approaching the minimum threshold with current connections. <b>Off</b> – No PoC is present.	
<b>CREWNET Status LEDs</b>	Left	<b>Green</b> – CrewNet connection is good.
		<b>Off</b> – No CrewNet connection detected.
	Right	<b>On (Green)</b> – 1000 Mbps link is detected.
		<b>Blinking (Green)</b> – Activity is detected.
		<b>Off</b> – No CrewNet connection detected.

# Product Specifications

**Table 2: Hub Product Specifications**

Specification*	CHB-8C-02	CHB-8F
CrewNet Ports (8 total connections)	(7) RJ-45 for copper; (1) RJ-45 for copper or duplex LC for Single Mode Fiber	(7) duplex LC for Single Mode Fiber; (1) RJ-45 for copper or duplex LC for Single Mode Fiber
Maximum CrewNet Line Length	Copper 330 ft. (100 m); Fiber 32,800 ft. (10,000 m)	Copper 330 ft. (100 m); Fiber 32,800 ft. (10,000 m)
External Power In	48VDC Power Supply	48VDC Power Supply
Power-over-CrewNet (PoC) In	Port 1 (RJ-45)	Port 1 (RJ-45)
Power-over-CrewNet (PoC) Out	Sourced by PoC: Ports 2–8; Sourced by external power: Ports 2–8	N/A
Dimensions (L × W × H)	8.62 in. × 1.73 in. × 8.68 in. (21.9 cm × 4.4 cm × 22 cm)	8.62 in. × 1.73 in. × 8.68 in. (21.9 cm × 4.4 cm × 22 cm)
Weight	1.75 lbs (794 g)	1.75 lbs (794 g)
Operating Environment	-20° to 50° C (-4° to 122° F); 10% to 90% Humidity.	-20° to 50° C (-4° to 122° F); 10% to 90% Humidity.
Maximum Altitude	6,562 ft. (2,000 m)	6,562 ft. (2,000 m)
RoHS	Yes	Yes

**\*Notice About Specifications:** While Pliant makes every attempt to maintain the accuracy of the information contained in this manual, this information is subject to change without notice, and published device/system functions and features are subject to firmware version. . Please check our website for the latest system specifications and certifications.

# Product Support

Pliant offers technical support via phone and email from 07:00 to 19:00 Central Time (UTC–06:00), seven days per week.

1.844.475.4268 or +1.334.321.1160  
technical.support@plianttechnologies.com

Visit [www.plianttechnologies.com](http://www.plianttechnologies.com) for product support, documentation, and live chat for help. (Live chat available 08:00 to 17:00 Central Time (UTC–06:00), Monday–Friday.)

## Returning Equipment for Repair or Maintenance

All questions and/or requests for a Return Authorization Number should be directed to the Customer Service department (customer.service@plianttechnologies.com). Do not return any equipment directly to the factory without first obtaining a Return Material Authorization (RMA) Number. Obtaining a Return Material Authorization Number will ensure that your equipment is handled promptly.

All shipments of Pliant products should be made via UPS, or the best available shipper, prepaid and insured. The equipment should be shipped in the original packing carton; if that is not available, use any suitable container that is rigid and of adequate size to surround the equipment with at least four inches of shock-absorbing material. All shipments should be sent to the following address and must include a Return Material Authorization Number:

Pliant Technologies Customer Service Department  
Attn: Return Material Authorization #  
205 Technology Parkway  
Auburn, AL 36830-0500



# Maintenance and Storage

## Cleaning

Generally, the CrewCom hardware should be cleaned only with a dry cloth. A soft cloth with rubbing alcohol may be used to wipe the devices if needed, but you should avoid using rubbing alcohol on plastic components. Never spray solvents or chemicals onto the devices.

All electronic devices can be susceptible to particulate contamination. If yours are exposed to an extremely dusty environment, contact Pliant's Customer Service for internal cleaning.

## Temperature and Humidity

CrewCom components are designed to be very durable and can tolerate a wide range of environmental conditions; however, you should take all necessary precautions to keep your system devices safe, dry, and out of extreme conditions.

The Radio Transceiver is weather-resistant, including gaskets intended to prevent moisture entry from the top and sides. The Cat 5e cable connection on the bottom is not water tight. If it is to be used in an outdoor environment, protect the RT with a protective enclosure that will not interfere with the RF.

The Radio Packs are designed to work wherever people work. While the Radio Pack design is weather-resistant, Radio Packs should not be submerged in liquids unnecessarily. Protect the battery compartment from water when changing batteries. The battery compartment offers a route to the electronic circuitry.

# License Information

**Warning: Changes or modifications to this device not expressly approved by Pliant could void the user's authority to operate the equipment.**

1. FCC Notices
  - 1.1. This equipment has been tested and found to comply with the limits for a Class A digital device, pursuant to part 15 of the FCC rules. These limits are designed to provide reasonable protection against harmful interference when the equipment is operated in a commercial environment. This equipment generates, uses, and can radiate radio frequency energy and, if not installed and used in accordance with the instruction manual, may cause harmful interference to radio communications. Operation of this equipment in a residential area is likely to cause harmful interference in which case the user will be required to correct the interference at his own expense.
2. Canada, Industry Canada (IC) Notices
  - 2.1. This Class A digital apparatus meets all requirements of the Canadian Interference Causing Equipment Regulations. Cet appareillage numérique de la classe A répond à toutes les exigences de l'interférence canadienne causant des règlements d'équipement.

## CrewCom Compliance Numbers

**Table 3: Hub Compliance Model Numbers**

Model Numbers	Compliance Model No.
CHB-8C	HB2520
CHB-8C-02	HB2520
CHB-8F	HB2521

# Warranty Information

## Limited Warranty

CrewCom products are warranted to be free from defects in materials and workmanship for a period of two years from the date of sale to the end user, under the following conditions:

- First year of warranty included with purchase.
- Second year of warranty requires product registration on the Pliant website.

Tempest professional products will carry a two-year product warranty.

All accessories carry a one-year warranty.

The sole obligation of Pliant Technologies, LLC during the warranty period is to provide, without charge, parts and labor necessary to remedy covered defects appearing in products returned prepaid to Pliant Technologies, LLC. This warranty does not cover any defect, malfunction, or failure caused by circumstances beyond the control of Pliant Technologies, LLC, including but not limited to negligent operation, abuse, accident, failure to follow instructions in the Operating Manual, defective or improper associated equipment, attempts at modification and/or repair not authorized by Pliant Technologies, LLC, and shipping damage. Products with their serial numbers removed or effaced are not covered by this warranty.

Pliant device IP ratings are dependent upon device design and assembly; therefore, unauthorized disassembly or device modifications may impair or negate the IP rating for the device, and therefore any associated damage or malfunction is not covered under this warranty.

This limited warranty is the sole and exclusive express warranty given with respect to Pliant Technologies, LLC products. It is the responsibility of the user to determine before purchase that this product is suitable for the user's intended purpose. ANY AND ALL IMPLIED WARRANTIES, INCLUDING THE IMPLIED WARRANTY OF MERCHANTABILITY, ARE LIMITED TO THE DURATION OF THIS EXPRESS LIMITED WARRANTY. NEITHER PLIANT TECHNOLOGIES, LLC NOR ANY AUTHORIZED RESELLER WHO SELLS PLIANT PROFESSIONAL INTERCOM PRODUCTS IS LIABLE FOR INCIDENTAL OR CONSEQUENTIAL DAMAGES OF ANY KIND.

## Parts Limited Warranty

Replacement parts for Pliant Technologies, LLC products are warranted to be free from defects in materials and workmanship for 120 days from the date of sale to the end user.

This warranty does not cover any defect, malfunction, or failure caused by circumstances beyond the control of Pliant Technologies, LLC, including but not limited to negligent operation, abuse, accident, failure to follow instructions in the Operating Manual, defective or improper associated equipment, attempts at modification and/or repair not authorized by Pliant Technologies, LLC, and shipping damage. Any damage done to a replacement part during its installation voids the warranty of the replacement part.

This limited warranty is the sole and exclusive express warranty given with respect to Pliant Technologies, LLC products. It is the responsibility of the user to determine before purchase that this product is suitable for the user's intended purpose. ANY AND ALL IMPLIED WARRANTIES, INCLUDING THE IMPLIED WARRANTY OF MERCHANTABILITY, ARE LIMITED TO THE DURATION OF THIS EXPRESS LIMITED WARRANTY. NEITHER PLIANT TECHNOLOGIES, LLC NOR ANY AUTHORIZED RESELLER WHO SELLS PLIANT PROFESSIONAL INTERCOM PRODUCTS IS LIABLE FOR INCIDENTAL OR CONSEQUENTIAL DAMAGES OF ANY KIND.

# Glossary

**Audio Output:** Outputs are created by mixing one or more audio entities. This could be for use at any headset connection or for output to a wired connection.

**Conference:** A grouping of audio entities. Wireless Radio Packs (or other CrewCom I/O) may be subscribed to one or more of 64 available Conferences.

**Control Unit (CCU-22 and CCU-44):** A CrewCom device that is used to establish a CrewNet system and provides initial system audio I/O. It is compatible with all levels of wireless Radio Packs.

**CrewCom Configuration File (CCF):** A file that stores all of the device setup and configuration parameters for a CrewCom system.

**CrewNet:** The digital proprietary network used to move audio and to control data, timing, and other functional signals used in CrewCom.

**CrewWare:** Software tool developed to incorporate all the necessary mechanisms for facilitating graphically based system construction and full system control, monitoring, and diagnosis.

**Firmware:** (As it relates to CrewCom.) The embedded code that exists in any CrewCom device. All of this embedded code, including radio code, is upgradeable easily by the end user. It is required that all CrewCom devices operate on the same version of firmware.

**Hub:** A device that provides routing and expansion capabilities to a CrewNet infrastructure allowing the connection of multiple CrewCom devices.

**Hub Layer:** The combining of multiple Copper and/or Fiber Hubs on a CrewCom system. Each additional Hub cascaded from a previous Hub is a new layer. Cascading can be direct from a previous Hub or routed through another CrewNet compatible device. A maximum of 32 hubs can be connected across four layers.

**ISM Bands:** Industrial, Scientific, and Medical Bands. A part of the radio spectrum that can be used for any purpose without a license in most countries.

**Power-Over-CrewNet:** A proprietary network protocol that provides operating voltage and current to devices that are connected to the CrewCom Control Unit.

**Profile:** A Radio Pack (RP) Profile assigns functionality to a RP's local controls, knobs, and buttons as well as what Conferences it subscribes to.

**Radio Pack:** The direct portable wireless communication device connecting individual CrewCom users to the CrewCom system. Sometimes commonly referred to as a BeltPack.

**Radio Transceiver:** A device used to remotely locate a radio and its corresponding antenna to provide an expanded coverage area.

**System Administrator:** A CrewCom top-level user who has configuration knowledge and capabilities. Certain system changes should be performed by the administrator.

**Wired Intercom:** Any hard wired duplex audio port for getting audio in or out of a system.

# Index

## Symbols

2-Wire 4, 5

4-Wire 4, 5

## A

AC Power 2

Audio Output 5

## C

Cat 5e. *See* Copper

Conference 5

Control Unit 4, 7

    Overview 4

Copper 3, 4, 6, 7, 8, 9, 12

CrewCom Configuration File 5, 7, 10

CrewNet 4, 5, 7, 8, 9, 10, 11, 12

CrewWare 4, 5, 7, 10

## F

Fiber 3, 4, 5, 6, 7, 8, 9, 10, 12

Firmware 7

## H

Hub 4, 10

    Operation 11

    Safety 1

    Specifications 12

Hub Layer 10, 17

## I

ISM Bands 4

## L

LED 6, 7, 8, 11

## P

PoC. *See* Power-over-CrewNet

Power-over-CrewNet 5, 7, 9, 11, 12

Profile 5

## R

Radio Pack 3, 4, 5

Radio Transceiver 4, 10

RJ-45 9, 10, 12

## S

Subscriber 5

Subscription 5

System Administrator 5

## W

Warranty 3, 15

Wired Intercom 5



Pliant Technologies, LLC  
205 Technology Parkway  
Auburn, AL 36830 USA  
[www.plianttechnologies.com](http://www.plianttechnologies.com)  
Phone +1.334.321.1160  
Toll-Free 1.844.475.4268 or 1.844.4PLIANT  
Fax +1.334.321.1162

Copyright ©2018–2019 Pliant Technologies. All rights reserved. The Pliant®, CrewCom®, and CrewNet™ word marks and the Pliant "P" logo are trademarks of Pliant Technologies, LLC. Any and all other trademark references within this document are property of their respective owners.