

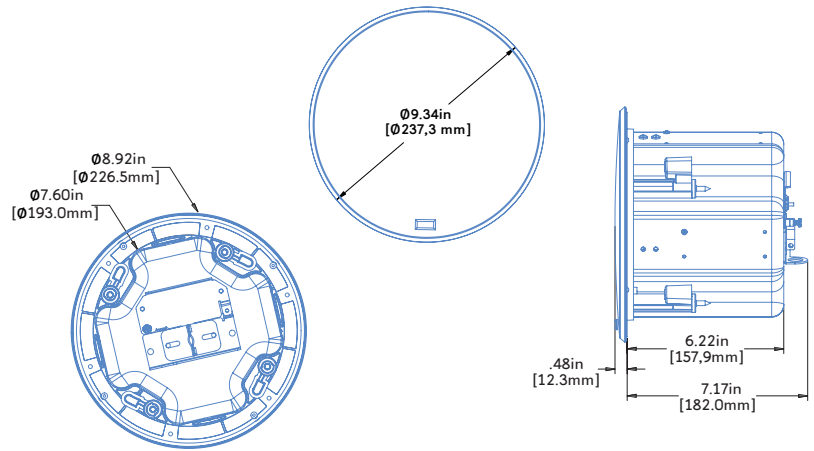

Ashby-5C Ceiling Loudspeaker



Outside Dimensions	8.92 in (226.5 mm) diameter 7.17 in (182 mm) depth: front of ceiling surface to built-in safety attachment ring
Cutout Diameter Range	7.70 - 7.95 in (195.5 - 201.9 mm)
Weight	7.8 lb (3.53 kg)
Enclosure	Zinc-plated steel-back can and UL 94 V-0 rated baffle
Grille	Perforated steel 9.34 in (237.3 mm) in diameter
Mounting Options	C-Ring with bridge kit, new construction bracket, and pendant mount

The Ashby-5C self-powered, ceiling-mounted loudspeaker provides wide coverage and low distortion, even at high sound levels, for applications that require accurate music reproduction and intelligible voice. The Ashby-5C outperforms all in-ceiling loudspeakers of comparable size.

The Ashby-5C is engineered to the same award-winning standards as all Meyer Sound IntelligentDC loudspeakers. With on-board amplification with sophisticated signal processing, the Ashby-5C exhibits the flat frequency and phase response for which Meyer Sound loudspeakers are known.

The Ashby drivers are designed and manufactured at the Meyer Sound factory in Berkeley, California. The 0.75-in metal-dome tweeter is concentrically mounted over a 5-in cone driver in an innovative configuration that maximizes the surface of the wave guide.

With an incredibly smooth, consistent 100° coverage, fewer loudspeakers can cover a larger area, which reduces system cost while maintaining the highest sound quality.

The Ashby-5C requires an external MPS-488HP IntelligentDC power supply. The 19-in (1 RU) unit distributes DC power and balanced audio to Ashby loudspeakers or other Meyer Sound IntelligentDC loudspeakers. Composite multi-conductor cables (e.g., Belden® 1502) can deliver both DC power and balanced audio from a single Phoenix™ 5-pin male connector.

The MPS-488HP can power up to 24 Ashby-5C loudspeakers (3 per channel) and can connect to Meyer Sound's RMS remote monitoring system. Using IntelligentDC to supply power from an external source has several advantages:

- Eliminates the need to use conduit (Class 2 wiring)
- Allows longer, lighter-gauge cable runs
- Preserves the advantages of self-powered systems with even more flexible installation options

Housed in an integrated metal back-can to meet commercial fire codes, the Ashby-5C can be flush-mounted in ceilings using a low-profile grille that blends discretely into any décor. The following Meyer Sound accessories are designed specifically to install Ashby loudspeakers into a variety of ceiling environments:

- **C-Ring with Bridge Kit:** Used for suspended ceilings, the C-ring better distributes the clamping force of the four mounting clamps, while the bridges help support and distribute the weight of the loudspeaker.
- **New Construction Bracket:** This bracket can be fastened to the ceiling and acts as a template for ceiling cutout, ensuring a neat installation.
- **Ashby Pendant:** Allows Ashby loudspeakers to hang from ceilings where a flush-mount is not practical. These elegant pendant enclosures utilize a minimalistic design typically used in pendant lighting to blend discretely into the environment.

Features and Benefits

- Self-powered
- Easy to install
- Extremely wide and consistent coverage
- Ultra low distortion
- Exceptional SPL-to-size ratio

- Beautiful reproduction of speech and music
- Supports long cable runs with light-gauge cables
- One MPS-488HP can power up to 24 Ashby-5Cs

APPLICATIONS

- Distributed systems for music and paging that demand high-quality audio and vocal intelligibility
- Constellation acoustic systems

SPECIFICATIONS

ACOUSTICAL		Operating Frequency Range ¹ Frequency Response ² Phase Response Linear Peak SPL ³	100 Hz – 18 kHz 110 Hz – 16 kHz ±4 dB 290 Hz – 16 kHz ± 45° 104.5 dB, Pink noise 107.5 dB, B-noise 112.0 dB, M-noise					
COVERAGE		Coverage	110° conical					
TRANSDUCERS		Low Frequency High Frequency	One 5-in cone driver One 0.75-in dome tweeter mounted concentrically in wave guide in front of 5-in driver					
CONNECTOR PANEL		Audio/Power Connector Pinout Power Wiring Audio Wiring LED	Two 5-pin female Phoenix (one input and a hard wired loop-output) Two pins for 48 DC power, three pins for balanced audio Pin 1: DC Power (-) Pin 2: DC Power (+) Pin 3: Audio shield, chassis/earth Pin 4: Signal (-) Pin 5: Signal (+) Displays loudspeaker status					
INPUT		Type Impedance Nominal Input Sensitivity Audio Input Source	Differential, electronically balanced 10 kΩ balanced (AC Impedance) -2.5 dBV (0.25 V rms, 1.00 V peak) continuous average is typically the onset of limiting for noise and music where pink noise has 12 dB peak-to-RMS ratio Audio source must be capable of producing +16 dBV (6.3 V rms, 9.0 V peak) into 600 Ω to produce the maximum peak SPL over the operating bandwidth of the loudspeaker with a sine wave.					
AMPLIFIER		Type Output Power ⁴ Cooling	High efficiency Class D 220 W (440 W peak) Natural convection through the metal enclosure					
DC POWER		48V DC Safety Agency Rated Operating Range ⁵ Current Draw Idle Current Maximum Long-Term Continuous Current (>3 sec) Maximum Instantaneous Peak Current Meyer Sound Power Supply Required	Powered from Meyer Sound MPS-488HP Power Supply Approved for Class 2 Wiring used in conjunction with MPS-488HP 48 V DC 0.16 A rms 0.32 A rms 1.70 A peak For information and specifications on the Meyer Sound MPS-488HP IntelligentDC external power supply, refer to its datasheet.					
COMPLIANCE		Safety Agency certification: EMC Certification:	Standard for audio, video and similar electronic apparatus: UL 60065, CSA C22.2 NO. 60065-03 (AMD 2), IEC 60065, IEC 62368-1 Fire Rated to UL Standard 2043, Product and Accessories Installed in Air-Handling Spaces CE and FCC Part 15 Emission Class B emission limits applied.					
MAXIMUM CABLE LENGTHS ⁶								
Number of Speakers	Maximum Cable Length (feet) – imperial				Maximum Cable Length (meters) – metric			
	12 AWG	14 AWG	16 AWG	18AWG	2.5 mm ²	1.5 mm ²	1.0 mm ²	0.75 mm ²
1	1800	1125	700	450	480	260	135	80
2	900	550	350	225	240	130	70	40
3*	600	375	237	150	160	87	45	27

* this applies to one 8C and one 5C looped

NOTES

1. Recommended maximum operating frequency range. Response depends on loading conditions and room acoustics.
2. Half-space loading, measured with 1/3-octave frequency resolution at 4 m.
3. Measured at 4 m and referred to 1 m.

Pink noise is an unfiltered, full range test signal with an average-to-peak ratio of 12.5 dB.

B-noise is a Meyer Sound test signal used to ensure measurements reflect system behavior when reproducing the most common input spectrum, and verify there is still headroom over pink noise.

M-noise is a full-range signal developed by Meyer Sound to better measure the loudspeaker's performance with music. It has a constant instantaneous peak level in octave bands, a crest factor that increases with frequency, and a full bandwidth peak-to-average ratio of 18 dB.

4. Amplifier wattage rating is based on the maximum unclipped burst sine wave rms voltage the amplifier will produce for at least 0.5 s into the nominal load impedance: 30 V rms (42 V peak).
5. Tolerates voltage drops up to 30% due to long cable runs. Normal operating conditions with recommended cable gauge, length, and number of speakers assures peak SPL to remain within 2 dB of max SPL specification.
6. Some high frequency loss can occur from long analog audio cables. For lengths greater than 500 ft (150 m) Meyer Sound recommends using low capacitance shielded audio cable or AES Digital audio cable. Discuss expected high frequency loss with the cable manufacturer to determine acceptability.



Ashby-5C
04.261.004.01A

Copyright © 2017
Meyer Sound Laboratories Inc.
All rights reserved

MEYER SOUND LABORATORIES INC.
2832 San Pablo Avenue
Berkeley, CA 94702

T: +1 510 486.1166

techsupport@meyersound.com
www.meyersound.com

ARCHITECTURAL SPECIFICATIONS

The loudspeaker shall be self-powered and include one 5-in (127 mm) diameter coaxial transducer and one 0.75-in (20 mm) dome tweeter mounted concentrically in wave guide in front of the 5-in driver.

Performance specifications for a typical production unit shall be as follows, measured at 1/3-octave resolution: operating frequency range, 100 Hz – 18 kHz; phase response, 290 Hz – 16 kHz ±45° and a conical coverage of 110 degrees. The loudspeaker shall be capable of maximum linear peak SPL of 112 dB peak at 1 m measured using M-noise, a full-range signal developed by Meyer Sound to better model the loudspeaker's performance with music.

The loudspeaker shall be equipped with two Phoenix 5-pin male connectors (pins 1, 2 for 48 V DC power, pins 3, 4, 5 for balanced audio). One shall be the input, the second connector shall be hard wired for looping.

The loudspeaker shall have looping capabilities, and when connected to one channel of the required power supply up to three units can be powered.

The audio input shall be electronically balanced with a 10 kohm impedance and shall accept a nominal -2.5 dBV (0.25 V rms, 1 V peak) signal.

The loudspeaker shall incorporate a highly efficient Class-D power amplifier with a total output power of 220 W (440 W peak).

Power requirements for the loudspeaker shall be a Meyer Sound MPS-488HP power supply, capable of delivering 48 V DC. Current draw for the loudspeaker shall be 0.16 A in idle state and its maximum long-term continuous current draw shall be 0.32 A with a duration of less than 3 s.

The loudspeaker shall tolerate voltage drops up to 30% caused by long cable runs when connected to one channel of the required power

supply. Maximum cable run for a single unit is 450 ft with 18 AWG (135 m with 1.0 mm²) and the maximum cable run for three looped units is 150 ft with 18 AWG (45 m with 1.0 mm²).

Loudspeaker components shall be housed in a zinc-plated steel enclosure which shall also include a UL94V-0 rated baffle. The enclosure shall incorporate 4 mounting clamps for flush-mount installations in ceilings and walls with a minimum depth of 7.17 in (182 mm). Grille shall be made of perforated steel and its diameter shall be 9.34 in (237.3 mm).

Dimensions shall be 8.92 in (226.5 mm) in diameter and 7.17 in (182 mm) in depth (front of ceiling surface to built-in safety attachment ring). Cutout diameter range shall be 7.60 – 7.875 in (193 – 200 mm). Weight shall be 7.8 lb (3.53 kg).

The loudspeaker shall be the Meyer Sound Ashby-5C.