

LYON™ Linear Line Array Loudspeaker



*Keep these important operating instructions.
Check www.meyersound.com for updates.*

© 2014–2020

Meyer Sound. All rights reserved.

LYON Operating Instructions, PN 05.232.005.01 B3





The contents of this manual are furnished for informational purposes only, are subject to change without notice, and should not be construed as a commitment by Meyer Sound Laboratories Inc. Meyer Sound assumes no responsibility or liability for any errors or inaccuracies that may appear in this manual. Except as permitted by applicable copyright law, no part of this publication may be reproduced, stored in a retrieval system, or transmitted, in any form or by any means, electronic, mechanical, recording or otherwise, without prior written permission from Meyer Sound.



CAL, Compass Go by Meyer Sound, Compass RMS, Intelligent AC, LEO-M, LEOPARD, LYON, MAPP, RMS, UltraSeries, and all alpha-numeric designations for Meyer Sound products and accessories are trademarks of Meyer Sound. Meyer Sound, Compass, Constellation, Galileo, LEO, QuickFly, Spacemap, Thinking Sound, TruPower, TruShaping, and U-Shaping, are registered trademarks of Meyer Sound Laboratories Inc. (Reg. U.S. Pat. & Tm. Off.). All third-party trademarks mentioned herein are the property of their respective trademark holders.

IMPORTANT SAFETY INSTRUCTIONS

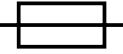
These symbols indicate important safety or operating features in this booklet and on the frame or chassis:

SYMBOLS USED

				
Dangerous voltages: risk of electric shock	Important operating instructions	Replaceable Fuse	Protective earth ground	Hot surface: do not touch
Gefährliche Spannungen: Stromschlaggefahr	Hinweis auf wichtige Punkte der Betriebsanleitung	Austauschbare Sicherung	Schutzerde	Heiße Oberfläche: nicht berühren
Pour indiquer les risques résultant de tensions dangereuses	Instructions d'utilisation importantes	Fusible remplaçable	Terre de protection	Surface chaude: ne pas toucher
Para indicar voltajes peligrosos	Instrucciones importantes de funcionamiento y/o Mantenimiento	Fusible reemplazable	Toma de tierra de protección	Superficie caliente: no tocar

1. Read these instructions.
 2. Keep these instructions.
 3. Heed all warnings.
 4. Follow all instructions.
 5. Do not use this apparatus near water.
 6. Clean only with dry cloth.
 7. Do not block any ventilation openings. Install in accordance with Meyer Sound's installation instructions.
 8. Do not install near any heat sources such as radiators, heat registers, stoves, or other apparatus that produce heat.
 9. Do not defeat the safety purpose of the grounding-type plug. A grounding type plug has two blades and a third grounding prong. The third prong is provided for your safety. If the provided plug does not fit into your outlet, consult an electrician for replacement of the obsolete outlet.
 10. Protect the power cord from being walked on or pinched, particularly at plugs, convenience receptacles, and the point where they exit from the apparatus. The AC mains plug or appliance coupler shall remain readily accessible for operation.
 11. Only use attachments/accessories specified by Meyer Sound.
 12. Use only with the caster rails or rigging specified by Meyer Sound, or sold with the apparatus. Handles are for carrying only.
 13. Unplug this apparatus during lightning storms or when unused for long periods of time.
 14. If equipped with an external fuse holder, the replaceable fuse is the only user-serviceable item. When replacing the fuse, only use the same type and the same value.
 15. Refer all other servicing to qualified service personnel. Servicing is required when the apparatus has been damaged in any way, such as when the power-supply cord or plug has been damaged; liquid has been spilled or objects have fallen into the apparatus; rain or moisture has entered the apparatus; the apparatus has been dropped; or when for undetermined reasons the apparatus does not operate normally.
-  **WARNING:** To reduce the risk of fire or electric shock, do not expose this apparatus to rain or moisture. Do not install the apparatus in wet or humid locations without using weather protection equipment from Meyer Sound.
-  **WARNING:** Class I apparatus shall be connected to a mains socket outlet with a protective earthing connection.
-  **CAUTION:** Disconnect the mains plug before disconnecting the power cord from the loudspeaker.

English

- To reduce the risk of electric shock, disconnect the apparatus from the AC mains before installing audio cable. Reconnect the power cord only after making all signal connections.
- Connect the apparatus to a two-pole, three-wire grounding mains receptacle. The receptacle must be connected to a fuse or circuit breaker. Connection to any other type of receptacle poses a shock hazard and may violate local electrical codes.
- Do not install the apparatus in wet or humid locations without using weather protection equipment from Meyer Sound.
- Do not allow water or any foreign object to get inside the apparatus. Do not put objects containing liquid on or near the unit.
- To reduce the risk of overheating the apparatus, avoid exposing it to direct sunlight. Do not install the unit near heat-emitting appliances, such as a room heater or stove.
- If equipped with an external fuse holder, the replaceable fuse is the only item that can be serviced by the user. When replacing the fuse, only use the same type and value.
- This apparatus contains potentially hazardous voltages. Do not attempt to disassemble the unit. The only user-serviceable part is the fuse. All other repairs should be performed only by factory-trained service personnel.

Deutsch

- Zur Minimierung der Gefahr eines elektrischen Schlages trennen Sie das Produkt vor dem Anschluss von Audio- und/oder Steuerleitungen vom Stromnetz. Das Netzkabel darf erst nach Herstellung aller Signalverbindungen wieder eingesteckt werden.
- Das Produkt an eine vorschriftsgemäss installierte dreipolige Netzsteckdose (Phase, Neutraleiter, Schutzleiter) anschließen. Die Steckdose muss vorschriftsgemäß mit einer Sicherung oder einem Leitungsschutzschalter abgesichert sein. Das Anschließen des Produkts an eine anders ausgeführte Stromversorgung kann gegen Vorschriften verstossen und zu Stromunfällen führen.
- Das Produkt nicht an einem Ort aufstellen, an dem es direkter Wassereinwirkung oder übermäßig hoher Luftfeuchtigkeit ausgesetzt werden könnte, solange es sich nicht um ein Produkt handelt, dass mit der Meyer Sound Weather Protection Option ausgestattet ist.
- Vermeiden Sie das Eindringen von Wasser oder Fremdkörpern in das Innere des Produkts. Stellen Sie keine Objekte, die Flüssigkeit enthalten, auf oder neben dem Produkt ab.
- Um ein Überhitzen des Produkts zu verhindern, halten Sie das Gerät von direkter Sonneneinstrahlung fern und stellen Sie es nicht in der Nähe von wärmeabstrahlenden Geräten (z.B. Heizgerät oder Herd) auf.

- Bei Ausstattung mit einem externen Sicherungshalter ist die austauschbare Sicherung das einzige Gerät, das vom Benutzer gewartet werden kann. Verwenden Sie beim Austausch der Sicherung nur den gleichen Typ und Wert.
- Dieses Gerät enthält möglicherweise gefährliche Spannungen. Versuchen Sie nicht, das Gerät zu zerlegen. Der einzige vom Benutzer zu wartende Teil ist die Sicherung. Alle anderen Reparaturen dürfen nur von im Werk geschultem Servicepersonal ausgeführt werden.

Français

- Pour éviter tout risque d'électrocution, débranchez l'enceinte de la prise secteur avant de mettre en place le câble audio. Ne rebranchez le cordon secteur qu'après avoir procédé à toutes les connexions de signal audio
- Brancher l'appareil sur une prise secteur à trois fils et deux pôles avec mise à la terre. La prise doit être reliée à un fusible ou à un disjoncteur. Le branchement à tout autre type de prise présente un risque de choc électrique et peut enfreindre les codes locaux de l'électricité.
- N'installez pas l'enceinte dans des endroits humides ou en présence d'eau sans utiliser d'équipements de protection adéquats fournis par Meyer Sound.
- Ne laissez pas d'eau ou d'objet étranger, quel qu'il soit, pénétrer à l'intérieur de l'enceinte. Ne posez pas d'objet contenant du liquide sur ou à proximité de l'enceinte.
- Pour réduire les risques de surchauffe, évitez d'exposer directement l'enceinte aux rayons du soleil. Ne l'installez pas à proximité de sources de chaleur, radiateur ou four par exemple.
- S'il est équipé d'un porte-fusible externe, le fusible remplaçable est le seul élément qui peut être réparé par l'utilisateur. Lors du remplacement du fusible, n'utilisez que le même type et la même valeur.
- Cet appareil contient des tensions potentiellement dangereuses. N'essayez pas de démonter l'appareil. Le fusible est la seule pièce réparable par l'utilisateur. Toutes les autres réparations doivent être effectuées uniquement par du personnel de maintenance formé en usine.

Español

- Para reducir el riesgo de descarga eléctrica, desconecte el aparato de la red eléctrica antes de instalar el cable de audio. Vuelva a conectar el cable de alimentación sólo después de realizar todas las conexiones de señal.
- Conecte el aparato a una toma de corriente de tres hilos y dos polos con conexión a tierra. El receptáculo debe estar conectado a un fusible o disyuntor. La conexión a cualquier otro tipo de receptáculo representa un riesgo de descarga eléctrica y puede violar los códigos eléctricos locales.

- No instale el aparato en lugares húmedos o mojados sin usar el equipo de protección contra intemperie de Meyer Sound.
- No permita que penetre agua u otros objetos extraños en el interior del aparato. No coloque objetos que contengan líquido sobre o cerca de la unidad.
- Para reducir el riesgo de sobrecalentamiento del aparato, evite exponerlo a la luz solar directa. No instale la unidad cerca de aparatos que emitan calor, como un calefactor o una estufa.
- Si está equipado con un portafusibles externo, el fusible reemplazable es el único elemento que puede ser reparado por el usuario. Cuando reemplace el fusible, use solamente el mismo tipo y valor.
- Este aparato contiene voltajes potencialmente peligrosos. No intente desmontar la unidad. La única pieza que el usuario puede reparar es el fusible. Todas las demás reparaciones deben ser realizadas únicamente por personal de servicio capacitado de fábrica.

CONTENTS

Important Safety Instructions	iii
Symbols Used	iii
Chapter 1: Introduction	9
How to Use This Manual	9
LYON Linear Line Array Loudspeaker	9
Chapter 2: Power Requirements	11
AC Power Distribution	11
AC Input	12
Wiring AC Power Cables	12
LYON Voltage Requirements	13
LYON Current Requirements	13
Do Not Reset Circuit Breakers!	13
Intelligent AC Power Supply	13
Electrical Safety Guidelines	14
Chapter 3: Amplification and Audio	15
Audio Connectors	15
Cable Rings	16
TruPower Limiting	16
Amplifier Cooling System	17
Chapter 4: QuickFly Rigging	19
Important Safety Considerations!	19
LYON Rigging Options	19
LYON GuideALinks	22
When to Move the Locking Pins to the “Stow Pin” Position	23
Chapter 5: RMS Remote Monitoring System	25
Compass RMS Software	25
RMS Module	25
Neuron ID for RMS Module	26
Resetting the RMS Module	26
Chapter 6: System Design and Integration Tools	27
MAPP System Design Tool	27
Galileo Galaxy Network Platform	28
	28
Appendix A: Product Integration	29
Delay Integration	29
Starting Points	31

Appendix B: Meyer Sound Weather Protection	33
Weather Protection Components	34
Installation Practices	34
IP Ratings	35
Appendix C: Rain Hoods	37
LYON Collapsible Rain Hood	37
LYON Quick-Clip Rain Hood	38
Appendix D: Specifications	41
LYON-M Dimensions	43
LYON-W, LYON-WXT Dimensions	44

CHAPTER 1: INTRODUCTION

HOW TO USE THIS MANUAL

Make sure to read these instructions in their entirety before configuring a Meyer Sound loudspeaker system. In particular, pay close attention to material related to safety issues.

As you read these instructions, you will encounter the following icons for notes, tips, and cautions:



NOTE: A note identifies an important or useful piece of information relating to the topic under discussion.

TIP: A tip offers a helpful tip relevant to the topic at hand.



CAUTION: A caution gives notice that an action may have serious consequences and could cause harm to equipment or personnel, or could cause delays or other problems.

Information and specifications are subject to change. Updates and supplementary information are available at www.meyersound.com.

Meyer Sound Technical Support is available at:

- **Tel:** +1 510 486.1166
- **Tel:** +1 510 486.0657 (after hours support)
- **Web:** www.meyersound.com/support

LYON LINEAR LINE ARRAY LOUDSPEAKER

The self-powered LYON™ linear line array loudspeaker (Figure 1) is a member of Meyer Sound's LEO® Family of linear loudspeakers, designed to reproduce audio faithfully with tremendous power and clarity, without coloring the sound, even when pushed to the limit. LYON delivers the same headroom and precision as the acclaimed LEO-M™ — with the same cutting-edge technology housed in a lighter and more compact cabinet. Optimized rigging and self-powered configuration streamline both setup and breakdown for LYON systems. LYON is ideal for medium- to large-scale array applications that do not require the extreme long-throw capability of LEO-M.



Figure 1: LYON Loudspeaker

For greater flexibility, LYON is available in three models: LYON-M for primary array coverage, LYON-W for wide coverage, and LYON-WXT for wide coverage with extended vertical coverage. LYON-W can be used wherever wide coverage is needed in LYON arrays, at the bottom or in the middle of primary arrays, or even at the top of outfill arrays. Because LYON-W matches the acoustical characteristics and vertical coverage of LYON-M, transitions for horizontal coverage are seamless. LYON models are matched acoustically to LEO-M and can be used for downfill and midfill at the bottom of LEO-M arrays, and as supplemental sidefill and outfill arrays in LEO-M systems.

LYON arrays are ideally paired with Meyer Sound's 1100-LFC low-frequency control element for bass reproduction. Entire systems are driven by Meyer Sound's Galileo GALAXY Network Processor, which provides matrix routing, alignment, and processing for array components. To guarantee optimum performance, including coverage patterns and maximum peak SPL, LYON systems should be designed with Meyer Sound's MAPP™ prediction software.

LYON's high-frequency section comprises two proprietary compression drivers coupled to a constant-directivity horn

through a patented REM® manifold. The manifold's smooth radiating characteristics afford tight vertical coverage. The low-frequency section includes two long-excursion cone drivers, also proprietary, capable of withstanding high, continuous output levels. Precise phase and magnitude alignment between low- and high-frequency drivers yields consistent and well-behaved system responses.

The unit's onboard power amplifier operates at nominal voltages from 85–134 V AC and 165–264 V AC at 50–60 Hz. TruPower® limiting ensures maximum driver protection, minimizing power compression while yielding high constant output under high continuous and peak power conditions. The amplifier, control electronics, and power supply are contained in a single field-replaceable module located on the rear of the cabinet.

Meyer Sound's RMS™ remote monitoring system comes standard with all LYON loudspeakers and provides comprehensive monitoring of system parameters on a Mac® or Windows®-based computer. Convenient XLR 5-pin connectors allow the use of composite cables carrying both RMS and balanced audio signals. XLR 3-pin audio connectors are also available.

LYON offers intuitive rigging with captive GuideALinks™ that can be set to the desired splay angles while cabinets rest in caster frames. The optional MTG-LYON top grid (Figure 2) flies arrays of up to 22 LYONs at a 5:1 safety factor (with some restrictions—always use MAPP to verify load ratings). The optional MTF-LEO/LYON transition frame flies LYONs at the bottom of LEO-M arrays. Stacks of up to four LYON cabinets can be securely transported with the optional MCF-LYON caster frame; durable nylon covers, accommodating stacks of two, three, or four units, are available to protect the cabinets during transport.

The LYON cabinet is constructed of premium multi-ply birch and coated with a slightly textured black finish. A powder-coated, hex-stamped, steel grille with acoustical black mesh protects the unit's drivers. Other options include weather protection and custom color finishes for fixed installations and applications with specific cosmetic requirements.



Figure 2: LYON Array with MTG-LYON Top Grid

CHAPTER 2: POWER REQUIREMENTS

LYON combines advanced loudspeaker technology with equally advanced power capabilities. Understanding power distribution, voltage and current requirements, and electrical safety guidelines is critical to the safe operation of LYON.

AC POWER DISTRIBUTION

All components in an audio system (self-powered loudspeakers, mixing consoles, and processors) must be properly connected to an AC power distribution system, ensuring that AC line polarity is preserved and that all grounding points are connected to a single node or common point using the same cable gauge (or larger) as the neutral and line cables.

CAUTION: Make sure the voltage received by LYON remains within its 85–134 V AC and 165–264 V AC operating ranges. In addition, the ground line must always be used for safety reasons and the line-to-ground voltage should never exceed 250 V AC (typically 120 V AC from line to ground).

CAUTION: Before applying AC power to any Meyer Sound self-powered loudspeaker, make sure that the voltage potential difference between the neutral and earth-ground lines is less than 5 V AC when using single-phase AC wiring.

NOTE: Improper grounding of connections between loudspeakers and the rest of the audio system may produce noise or hum, or cause serious damage to the input and output stages of the system's electronic components.

120 V AC, 3-Phase Wye System (Single Line)

Line-Neutral-Earth/Ground

Figure 3 illustrates a basic 120 V AC, 3-phase Wye distribution system with the loudspeaker load distributed across all three phases, with each loudspeaker connected to a single line and common neutral and earth/ground lines. This system delivers 120 V AC to each loudspeaker.

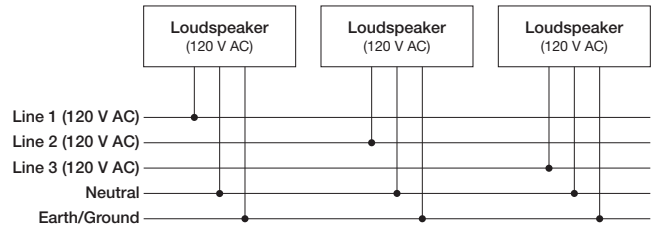

Figure 3: 120 V AC, 3-Phase Wye System (Single Line to Loudspeakers)

120 V AC, 3-Phase Wye System (Two Lines)

Line-Line-Earth/Ground

Figure 4 illustrates a 120 V AC, 3-phase Wye distribution system with each loudspeaker connected to two lines and a common earth/ground line. This configuration is possible because LYON tolerates elevated voltages from the ground line and does not require a neutral line. This system delivers 208 V AC to each loudspeaker.

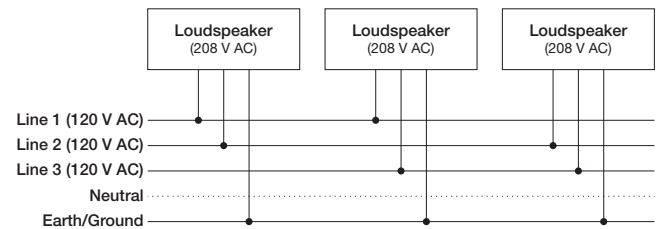

Figure 4: 120 V AC, 3-Phase Wye System (Two Lines to Loudspeakers)

TIP: The 120 V AC, 3-phase Wye system with two lines is recommended because it allows loudspeakers to draw less current than with single-line systems, thereby reducing voltage drop due to cable resistance. It also excludes the potential of varying ground to neutral voltages producing an audible hum.

230 V AC, 3-Phase Wye System (Single Line)

Line-Neutral-Earth/Ground

Figure 5 illustrates a basic 230 V AC, 3-phase Wye distribution system with the loudspeaker load distributed across all three phases, with each loudspeaker connected to a single line and common neutral and earth/ground lines. This system delivers 230 V AC to each loudspeaker.

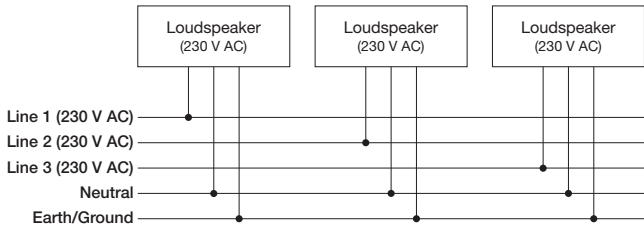

Figure 5: 230 V AC, 3-Phase Wye System (Single Line to Loudspeakers)

CAUTION: For 230 V AC, 3-phase Wye systems, never connect two lines to the AC input of LYON, as the resulting voltage would exceed the upper voltage limit (275 V AC) and will damage the loudspeaker.

AC INPUT

The LYON user panel includes an AC Input connector that supplies power to the loudspeaker. The 3-conductor PowerCON 32 (Figure 6) is rated at 32 A and uses a locking connector that prevents accidental disconnections.



Figure 6: PowerCON 32 AC Input Connector

LYON ships with a black powerCON 32 cable mount connector, rated at 32 A, for assembling AC power cables. Make sure to use an AC power cable that is wired correctly (see “Wiring AC Power Cables” on page 12) and equipped with the appropriate power plug (on the other end) for the area in which you will operate the unit.

LYON requires a grounded outlet. To operate safely and effectively, it is extremely important that the entire system be properly grounded.

WIRING AC POWER CABLES

LYON ships with a black powerCON 32 cable mount connector (Figure 7), rated at 32 A, for assembling AC power cables. The pins on the powerCON 32 cable mount connector are labeled as follows:

- L (Line)
- N (Neutral)
- PE (Protective Earth or Ground)

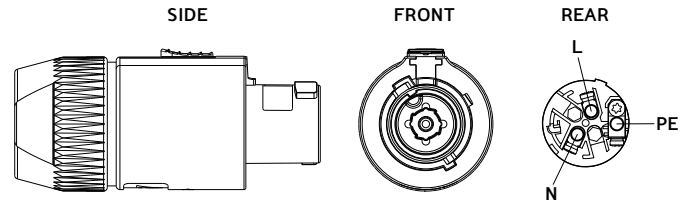

Figure 7: PowerCON 32 Cable Mount Connector

How AC power cables are wired is determined by the type of AC power distribution system used (see “AC Power Distribution” on page 11). When wiring AC power cables for single-line systems, use one of the wiring schemes described in Table 1 and illustrated in Figure 8:

Table 1: AC Wiring Scheme

Wire Color		Attach to the Following Terminal
U.S. / Canada 60 Hz	European 50 Hz	
Black	Brown	Hot or live (L)
White	Blue	Neutral (N)
Green	Green and Yellow	Protective earth / ground (E or PE)

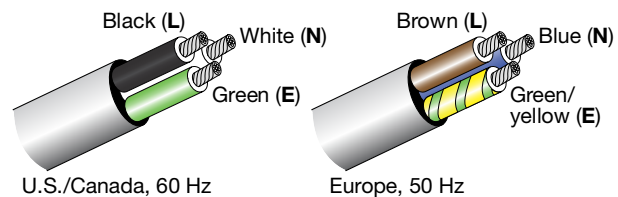

Figure 8: AC Wiring Scheme, illustrated

CAUTION: When wiring AC power cables and distribution systems, it is important to preserve AC line polarity and connect the earth ground on both ends of the cable. LYON requires a grounded connection. Always use a grounded outlet and plug. It is extremely important that the system be properly grounded to operate safely and properly. Do not ground-lift the AC cable.

Supported PowerCON 32 Cable Gauges

While the powerCON 32 connector supports cable gauges of 14–10 AWG (2.5–6.0 mm²), because of LYON’s current draw, 10 AWG (6.0 mm²) should be used whenever possible.

LYON VOLTAGE REQUIREMENTS

LYON operates as intended when receiving AC voltage within the following ranges:

- 85–134 V AC, 50–60 Hz
- 165–264 V AC, 50–60 Hz

If the voltage drops below 85 V, the loudspeaker uses stored power to continue operating temporarily; the loudspeaker powers off if the voltage does not return to its operating range.

If the voltage rises above 275 V, the power supply could become damaged.

 **CAUTION:** The power source for LYON should always operate within the required operating range, at least a few volts from the upper and lower limits. This ensures that AC voltage variations from the service entry—or peak voltage drops due to cable runs—will not cause the loudspeaker’s amplifier to cycle on and off or cause damage to the power supply.

LYON CURRENT REQUIREMENTS

Current draw for loudspeakers is dynamic and fluctuates as operating levels change. Because different cables and circuit breakers heat up at varying rates, it is important to understand the following types of current ratings and how they affect circuit breaker and cable specifications.

- **Idle Current** — The maximum rms current during idle periods.
- **Maximum Long-Term Continuous Current** — The maximum rms current during a period of at least 10 seconds. The maximum long-term continuous current is used to calculate temperature increases for cables to ensure that the size and gauge of the cables conform to electrical code standards. The current rating is also used to select appropriately rated, slow-reacting thermal breakers, which are recommended for loudspeaker power distribution.
- **Burst Current** — The maximum rms current during a period of around 1 second. The burst current is used as a rating for magnetic breakers. It is also used for calculating the peak voltage drop in long AC cable runs according to the following formula:

$$V_{pk} (\text{drop}) = I_{pk} \times R (\text{cable total})$$

- **Maximum Instantaneous Peak Current** — A rating for fast-reacting magnetic breakers.
- **Inrush Current** — The spike of initial current encountered when powering on.

Use the information provided in Table 2 as a guide for selecting the gauge of cables and the circuit breaker ratings for the system’s operating voltage.

Table 2: LYON Current Draw

Current Draw	208 V AC	230 V AC	100 V AC
Idle	0.7 A rms	0.6 A rms	1.2 A rms
Maximum Long-Term Continuous	6.2 A rms	5.6 A rms	11.2 A rms
Burst	8.2 A rms	7.5 A rms	15.4 A rms
Maximum Instantaneous Peak	25 A peak	23 A peak	45 A peak
Inrush	<15 A peak	<15 A peak	<15 A peak

The minimum electrical service amperage required by a loudspeaker system is the sum of the maximum long-term continuous current for all loudspeakers. An additional 30 percent above the combined Maximum Long-Term Continuous amperages is recommended to prevent peak voltage drops at the service entry.



NOTE: For best performance, the AC cable voltage drop should not exceed 10 V (10 percent at 115 V and 5 percent at 230 V). This ensures that the AC voltage variations from the service entry—or peak voltage drops due to longer cable runs—do not cause the amplifier to cycle on and off.

DO NOT RESET CIRCUIT BREAKERS!



CAUTION: In the unlikely event that one of LYON’s circuit breakers trips (the center button disengages), disconnect the AC power cable and contact Meyer Sound for repair information. DO NOT attempt to reset the breaker or reconnect the AC power cable.

INTELLIGENT AC POWER SUPPLY

LYON’s Intelligent AC™ power supply automatically selects the correct operating voltage (allowing the loudspeaker to be used internationally without manually setting voltage switches), eliminates high inrush currents with soft-start power up, suppresses high-voltage transients up to several kilovolts, filters common mode and differential mode radio

frequencies (EMI), and sustains operation temporarily during low-voltage periods.

power cable (and audio cables). Do not use the cable rings for any other purpose.

Powering on LYON

When powering on LYON, the following startup events take place over several seconds.

1. Audio output is muted.
2. Voltage is detected and the power supply mode is automatically adjusted as necessary.
3. The primary fan turns on.
4. The power supply ramps up.
5. On the user panel, the Active/Status LED flashes multiple colors successively.
6. The Active/Status LED turns solid green, indicating the loudspeaker is already unmuted and ready to output audio.



CAUTION: If the Active/Status LED does not turn solid green, or LYON does not output audio after 10 seconds, remove AC power immediately and verify that the voltage is within the required range. If the problem persists, contact Meyer Sound Technical Support.

ELECTRICAL SAFETY GUIDELINES

Make sure to observe the following important electrical and safety guidelines.

- The powerCON 32 connector should not be engaged or disengaged when under load or energized. Either de-energize or disconnect the other end of the cable.
- LYON requires a grounded outlet. Always use a grounded outlet and plug.
- Do not use a ground-lifting adapter or cut the AC cable ground pin.
- Make sure the AC power cable for the loudspeaker has the appropriate power plug (on the other end) for the area in which you will operate the loudspeaker.
- Do not operate the loudspeaker if the power cable is frayed or broken.
- Keep all liquids away from LYON loudspeakers to avoid hazards from electrical shock.
- Use the cable rings (see “Cable Rings” on page 16) on the rear of the LYON cabinet to reduce strain on the AC

CHAPTER 3: AMPLIFICATION AND AUDIO

LYON's drivers are powered by a proprietary three-channel amplifier with bridged MOSFET output stages. The audio signal is processed with an electronic crossover plus correction filters for flat phase and frequency responses, and by driver protection circuitry. Each channel has peak and rms limiters that prevent driver over-excursion and regulate voice coil temperatures.

The LYON user panel (Figure 9) includes Input and Loop output connectors for audio, Limit and Active LEDs, and RMS connectors and controls (see Chapter 5, "RMS Remote Monitoring System").

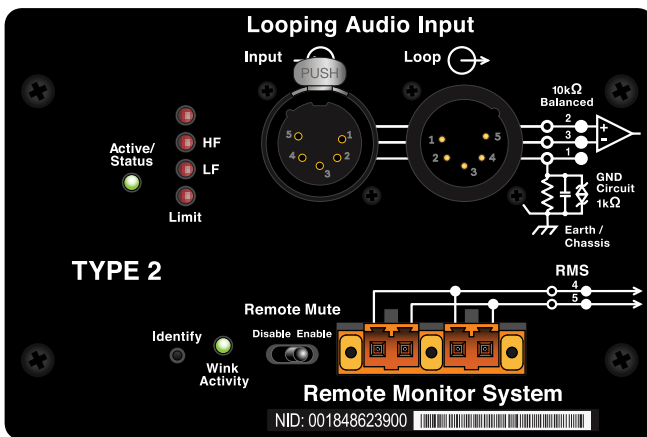

Figure 9: LYON User Panel

AUDIO CONNECTORS

LYON is available with XLR 3-pin or 5-pin connectors for audio Input and audio Loop output (Figure 10 and Figure 11). XLR 5-pin connectors accommodate both balanced audio and RMS signals.

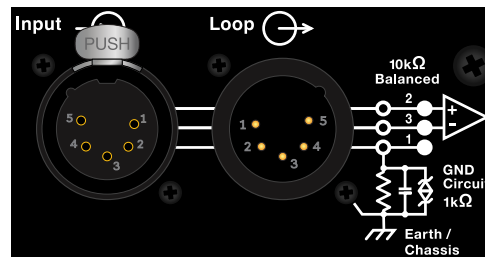

Figure 10: XLR 5-Pin Audio Connectors, Input and Loop Output

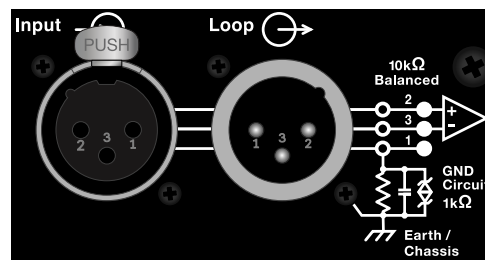



Figure 11: XLR 3-Pin Audio Connectors, Input and Loop Output

Audio Input (XLR 3-Pin or 5-Pin Female)

The XLR 3-pin or 5-pin female Input connector accepts balanced audio signals with an input impedance of 10 kOhm. The connector uses the following wiring scheme:

- **Pin 1** – 1 kOhm to chassis and earth ground (ESD clamped)
- **Pin 2** – Signal (+)
- **Pin 3** – Signal (-)
- **Pin 4** – RMS (polarity insensitive)
- **Pin 5** – RMS (polarity insensitive)
- **Case** – Earth (AC) ground and chassis

 **NOTE:** Pins 4 and 5 (RMS) are included only with XLR 5-pin connectors.

Pins 2 and 3 carry the input as a differential signal. Pin 1 is connected to earth through a 1 kOhm, 1000 pF, 15 V clamped network. This circuitry provides virtual ground lift for audio frequencies while allowing unwanted signals to bleed to ground. Make sure to use balanced XLR audio cables with pins 1–3 connected on both ends. Telescopic grounding is not recommended and shorting an input connector pin to the case may cause a ground loop, resulting in hum.

 **TIP:** If unwanted noise or hiss is produced by the loudspeaker, disconnect its input cable. If the noise stops, there is most likely nothing wrong with the loudspeaker. To locate the source of the noise, check the audio cable, source audio, AC power, and electrical ground.

Audio Loop Output (XLR 3-Pin or 5-Pin Male)

The XLR 3-pin or 5-pin male Loop output connector allows multiple loudspeakers to be looped from a single audio source. The Loop output connector uses the same wiring scheme as the Input connector (see “Audio Input (XLR 3-Pin or 5-Pin Female)” on page 15). For applications that require multiple LYONs, connect the Loop output of the first loudspeaker to the Input of the second loudspeaker, and so forth.

 **NOTE:** The Loop output connector is wired in parallel to the Input connector and transmits the unbuffered source signal even when the loudspeaker is powered off.

Calculating Load Impedance for Looped Audio Signals

To avoid distortion when looping multiple loudspeakers, make sure the source device can drive the total load impedance of the looped loudspeakers. In addition, the source device must be capable of delivering approximately 20 dBV (10 V rms into 600 ohms) to yield the maximum SPL over the operating bandwidth of the loudspeakers.

To calculate the load impedance for the looped loudspeakers, divide 10 kOhms (the input impedance for a single loudspeaker) by the number of looped loudspeakers. For example, the load impedance for ten LYONs is 1000 ohms (10 kOhms / 10). To drive this number of looped loudspeakers, the source device should have an output impedance of 100 ohms or less. This same rule applies when looping LYONs with other Meyer Sound self-powered loudspeakers.

 **NOTE:** Most source devices are capable of driving loads no less than 10 times their output impedance.

 **TIP:** Audio outputs from Meyer Sound’s Galileo GALAXY Network Platform have an output impedance of 50 ohms. Each output can drive up to 20 Meyer Sound (10 kOhm) loudspeakers without distortion.

 **CAUTION:** Make sure that all cabling for looped loudspeakers is wired correctly (Pin 1 to Pin 1, Pin 2 to Pin 2, and so forth) to prevent the polarity from being reversed. If one or more loudspeakers in a system have reversed polarity, frequency response and coverage will be significantly degraded.

CABLE RINGS

Two cable rings are provided on the rear of the LYON cabinet (Figure 12). Power and audio cables should be tied off to the rings to reduce strain on the cables and prevent damage to them during installation. The cable rings should not be used for any other purpose.

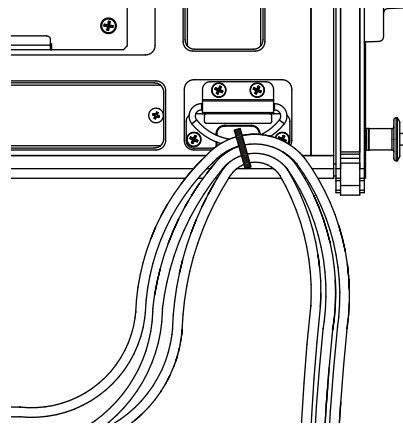



Figure 12: Cables Tied Off to Cable Ring

 **CAUTION:** LYON cable rings should only be used to reduce strain on cables. The cable rings should not be used for any other purpose.

TRUPOWER LIMITING

LYON employs Meyer Sound’s advanced TruPower® limiting. Conventional limiters assume a constant loudspeaker impedance and set the limiting threshold by measuring voltage alone. This method is inaccurate because loudspeaker impedances change as frequency content in the

source material changes, and as thermal values for the loudspeaker's voice coil and magnet vary. Consequently, conventional limiters often begin limiting prematurely, which reduces system headroom and dynamic range.

In contrast, TruPower limiting anticipates varying loudspeaker impedances by measuring both current and voltage to compute the actual power dissipation in the voice coil. This approach improves performance, both before and during limiting, by allowing the driver to produce the maximum SPL across its entire frequency range, while also retaining signal peaks. TruPower limiting also eliminates power compression at high levels over lengthy periods, which helps regulate voice coil temperatures, thereby extending the life of the driver.

HF and LF Limit LEDs

The low- and high-frequency drivers for LYON are powered by separate amplifier channels, each with their own limiter. Limiting activity is indicated with two Limit LEDs on the user panel (Figure 13). The HF Limit LED indicates limiting for the high-frequency channel and the LF Limit LED indicates limiting for the low-frequency channel.

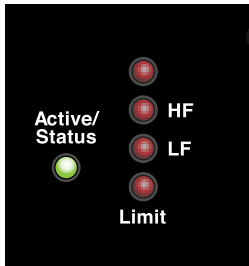

Figure 13: LYON Limit LEDs

When engaged, the limiters not only protect the drivers but also prevent signal peaks from causing excessive distortion in the amplifier channels, thereby preserving headroom and maintaining smooth frequency response at high levels. When levels return to normal, below the limiter thresholds, limiting ceases.

LYON performs within its acoustical specifications at normal temperatures when the Limit LEDs are unlit, or when the LEDs are lit for 2 seconds or less and then turn off for at least 1 second. If the LEDs remain lit for longer than 3 seconds, the loudspeaker enters hard limiting where:

- Increases to the input level have no effect
- Distortion increases due to clipping
- Drivers are subjected to excessive heat and excursion, thereby compromising their lifespan

CAUTION: The Limit LEDs indicate when a safe, optimum level is exceeded. If a LYON loudspeaker system begins to limit before reaching the desired SPL, consider adding more loudspeakers to the system.

AMPLIFIER COOLING SYSTEM

LYON employs forced-air cooling with four ultra high-speed fans (two primary, and two reserve) to prevent the amplifier from overheating (see Table 3 for details). The fans draw air in through ducts on the rear of the cabinet, over the heat sinks, and out the rear of the cabinet. Because dust does not accumulate in the amplifier and power circuitry, their lifespans are increased significantly.

CAUTION: To keep LYON from overheating, allow at least 6 inches behind the cabinet for proper ventilation.

Table 3: LYON Fans

	Primary Fans		Reserve Fans	
Type	Ultrahigh-speed		Ultrahigh-speed	
Number	2		2	
Location	1 for each heat sink (2)		1 for each heat sink (2)	
Fan speeds and heat sink temp.	<34 °C	Half speed	<52 °C	Off
	34–50 °C	Ramps up	>52 °C	Full speed
	50–84 °C	Full speed		
	>95 °C	Audio muted, fans continue at full speed	>95 °C	Audio muted, fans continue at full speed
	<86 °C	Audio unmuted, fans continue at full speed	<86 °C	Audio unmuted, fans continue at full speed

CAUTION: If a LYON loudspeaker system consistently overheats before reaching the desired SPL, consider adding more loudspeakers to the system.

TIP: When LYON is connected to an RMS network, the Compass RMS software provides additional feedback on the loudspeaker's hardware status and operating temperature. For more information, see Chapter 5, "RMS Remote Monitoring System."

CHAPTER 4: QUICKFLY RIGGING

IMPORTANT SAFETY CONSIDERATIONS!

When installing Meyer Sound loudspeakers and subwoofers, the following precautions should always be observed:

- All Meyer Sound products must be used in accordance with local, state, federal, and industry regulations. It is the owner's and user's responsibility to evaluate the reliability of any rigging method for their application. Rigging should only be carried out by experienced professionals.
- Use mounting and rigging hardware that has been rated to meet or exceed the weight being hung.
- Make sure to attach mounting hardware to the building's structural components (roof truss), and not just to the wall surface.
- Make sure bolts and eye bolts are tightened securely. Meyer Sound recommends using Loctite® on all threaded fasteners.
- Inspect mounting and rigging hardware regularly. Immediately replace any worn or damaged components.

LYON RIGGING OPTIONS

Table 4 summarizes the available rigging options for LYON. For complete information about rigging hardware, including dimensions, weight, configuration, and load ratings, refer to the MTG-LYON Assembly Guide (PN 05.232.097.01) available at www.meyersound.com.

Table 4: LYON Rigging Options

Model	Weight	Features	Required Quick-Release Pins	Required Shackles
MTG-LYON top grid (PN 40.232.038.01)	171 lb (77.6 kg)	With some restrictions, flies up to 22 LYONs at a 5:1 safety factor; accommodates a variety of pickup configurations with six pickup points; includes attachment points to accommodate brackets and adapters for lasers and inclinometers	7/16 x 1.50-inch (red button), PN 134.051, qty 4 included	3/4-inch or 7/8-inch
MVP motor Vee plate (PN 40.215.184.01)	20 lb (9.1 kg)	Fine tunes the horizontal aim of arrays; compatible with MTG-LEO-M, MTG-LYON, MTG-1100, and MG-LEOPARD/900 grids	—	3/4-inch or 7/8-inch
MTF-LEO-M/LYON transition frame (PN 40.215.250.01)	85 lb (38.6 kg)	With some restrictions, flies up to eight LYONs at a 5:1 safety factor below LEO-M arrays for downfill; includes rear attachment points for pull-back	7/16 x 1.50-inch (red button), PN 134.051, qty 4 included	5/8-inch
			5/16 x 0.875-inch (red button), PN 134.025, qty 4 included	
MTF-LYON/LEOPARD transition frame (PN 40.232.140.01)	71 lb (32.2 kg)	With some restrictions, flies up to ten LEOPARDS at a 5:1 safety factor below LYON arrays for downfill; includes rear attachment points for pull-back; collapsible for easy transport on top of LEOPARD stacks	7/16 x 0.90-inch (black button), PN 134.050, qty 0 included	1/2-inch or 5/8-inch
			5/16 x 0.875-inch, red button, PN 134.025, qty 8 included	
PBF-LYON pull-back frame (PN 40.232.125.01)	9.5 lb (4.3 kg)	Attaches to bottom of LYON arrays (to the bottom cabinet) and provides pull-back for extreme array downtilt; can also be used for pull-up to expand the array's splay angles during installation so the blue locking pins can be more easily inserted	7/16 x 0.90-inch (black button), PN 134.050, qty 0 included	5/8-inch
RPP-LEO-M rear pull-up plate (PN 40.215.181.01)	6 lb (2.7 kg)	Helps assemble large arrays with wide splay angles by providing pull-up (with a motor) to expand the array's splay angles during installation so the blue locking pins can be more easily inserted	1/2 x 2.50-inch (blue button), PN 134.007, qty 2 included	5/8-inch
MCF-LYON caster frame (PN 40.232.045.01)	90 lb (40.8 kg)	Safely transports up to four LYON cabinets, making it easy to assemble and disassemble arrays in blocks of four cabinets	7/16 x 0.90-inch (black button), PN 134.050, qty 0 included	—



NOTE: The MCF-LYON caster frame and PBF-LYON do not include quick-release pins because they are secured with the quick-release pins included with the loudspeaker.

Rigging Example, LYON Array with Pull-Up

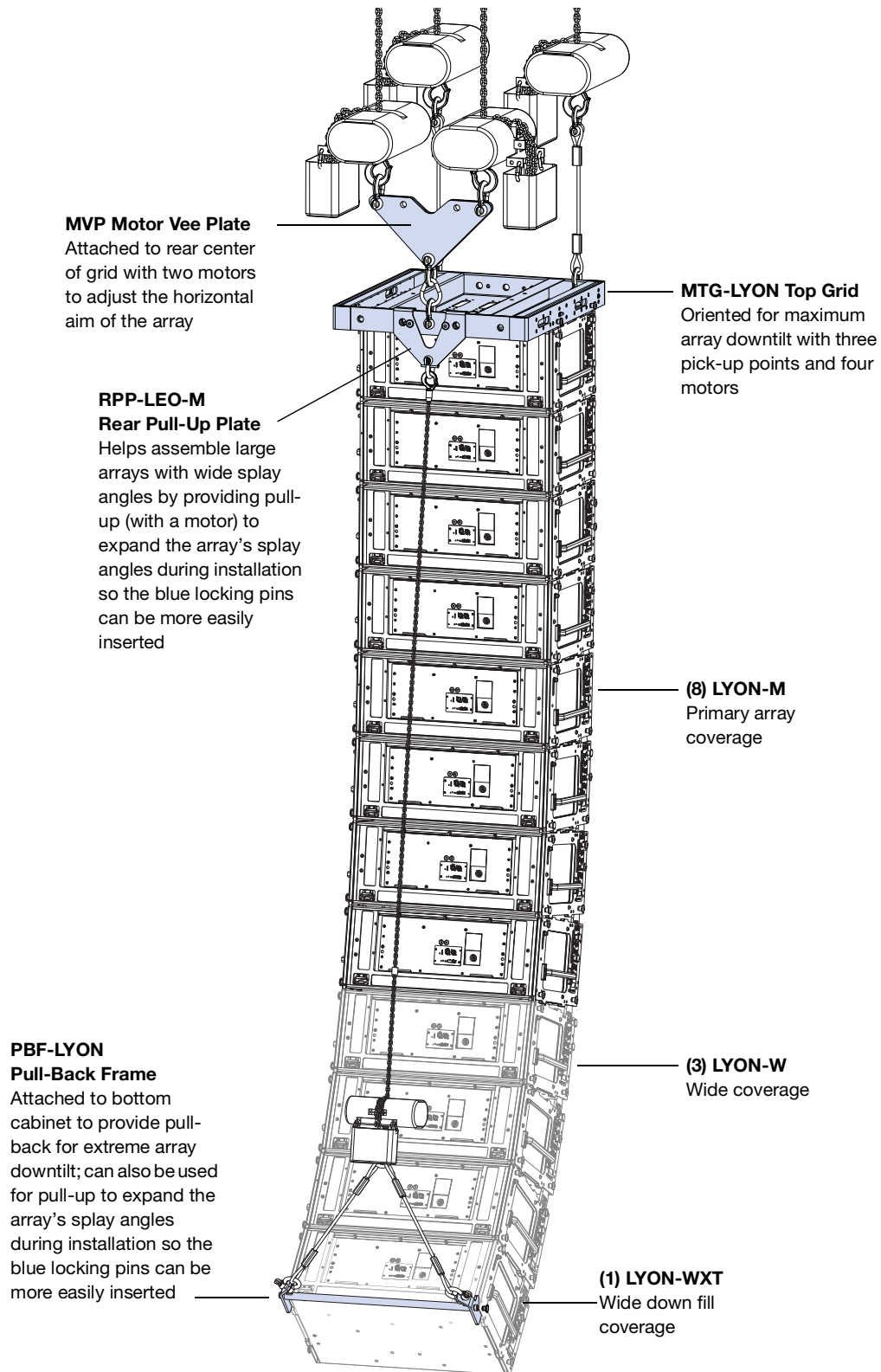

Rigging Example, LYON Array with LEOPARD Downfill

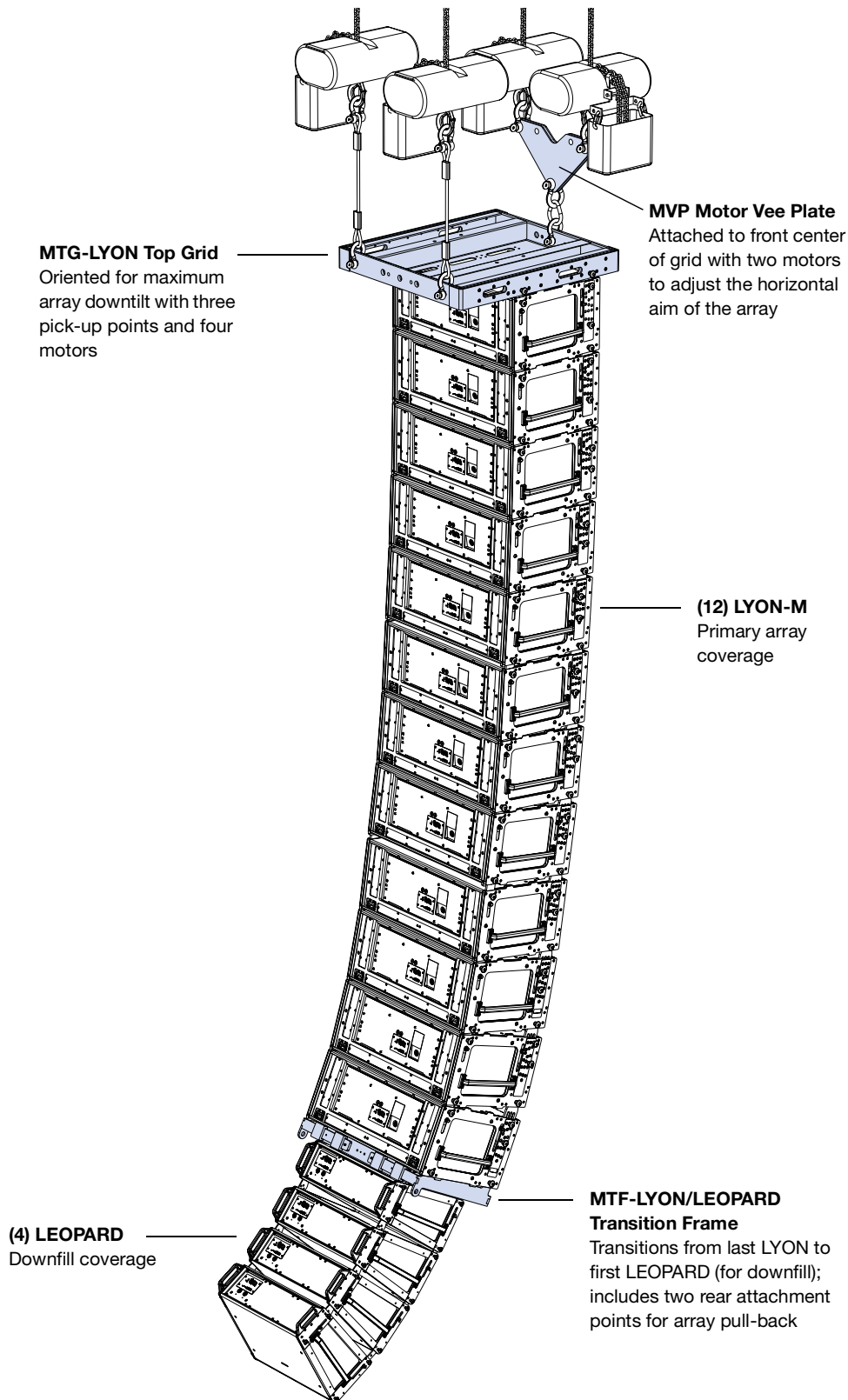

LYON GUIDEALINKS

LYON is equipped with four captive GuideALinks and four mating link slots that link to adjacent units in flown arrays. Located at the top corners of the cabinet, GuideALinks extend up and into the link slots of the cabinet above it, or into the link slots of the MTG-LYON grid, making it easy to link cabinets once they are stacked (Figure 14 and Figure 15). GuideALinks extend and retract with knobs and are secured with two quick-release pins: one each in the top and bottom cabinets. Each LYON loudspeaker ships with 10 7/16 x 0.90-inch quick-release pins (black button) (PN 134.050).

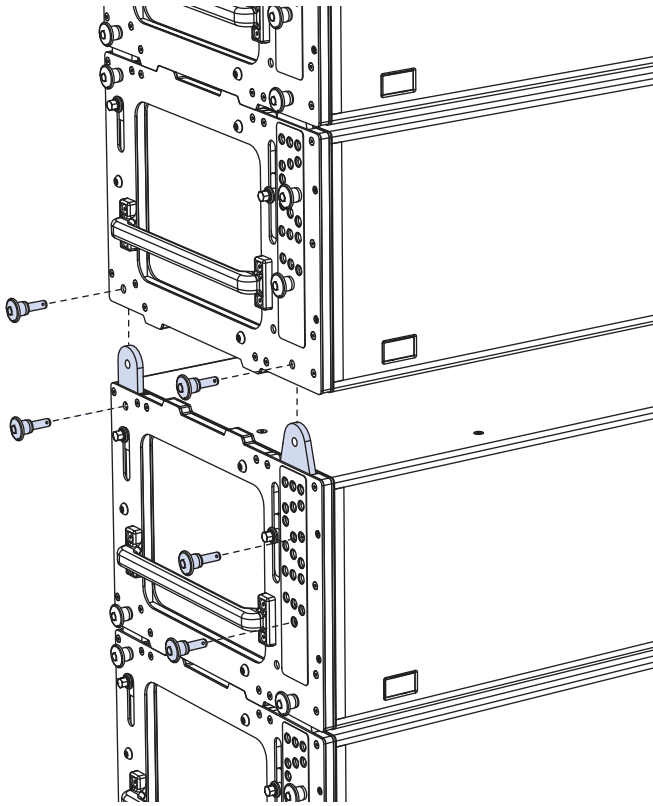

Figure 14: LYON GuideALinks with Quick-Release Pins, Exploded View

CAUTION: GuideALinks must be secured with the included quick-release pins. At no time should the weight of the loudspeaker rest on the GuideALink knobs when the links are fully extended (without the pins inserted). GuideALink knobs are for extending and retracting the links only.

LYON Splay Angles

Rear GuideALinks attach at a fixed splay angle of 0 degrees and act as a pivot point between linked LYONs, with the splay angle between the units determined by the front GuideALink

positions. Rear GuideALinks can be pinned in either of two positions: extended or stowed.

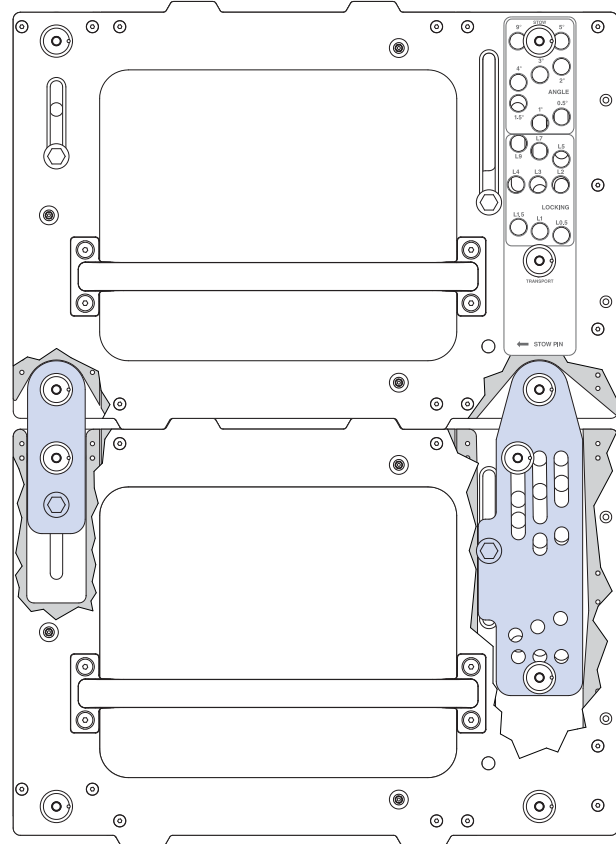

Figure 15: LYON GuideALinks (Exposed) Attached at 0 Degrees

Front GuideALinks determine the loudspeaker splay angles and are configured with the yellow ANGLE positions when the cabinets are resting in the caster frame (Figure 16). After the stack is lifted with the motors, the loudspeakers rotate on the axis of the rear GuideALinks and the front GuideALinks slide into position as the weight of the loudspeakers causes the cabinets to shift, at which point, quick-release pins are inserted in the corresponding blue LOCKING positions to lock the splay angles.

Available splay angles for linked LYONs include 0.0, 0.5, 1.0, 1.5, 2.0, 3.0, 4.0, 5.0, 7.0, and 9.0 degrees and are indicated by the blue and yellow GuideALink labels.

CAUTION: Splay angles of 0 degrees should only be used for the top cabinet attached to the grid. Splay angles of at least 0.5 degrees are recommended for cabinets near the top of the array. If multiple cabinets are set to 0 degrees and the array is flown with downtilt, the resulting splay angles could be negative because of the gaps in the links and pins that facilitate easy pinning.



NOTE: The splay angles listed on the GuideALink labels are for relative angles between the center axes of the linked units. For example, setting the GuideALinks to 5 degrees yields a 5-degree downtilt of the lower unit to the upper unit. How the loudspeakers relate to the floor, stage, and seating angles in the venue depends on the orientation of the grid, the angles of the loudspeakers in the array above them, and other factors. MAPP prediction software should be used to calculate optimum splay angles for loudspeakers and to predict coverage patterns for arrays.

WHEN TO MOVE THE LOCKING PINS TO THE “STOW PIN” POSITION

The quick-release pins in the blue LOCKING positions must be moved to the STOW PIN position before either lifting or lowering an array. The removal of the quick-release pins from the LOCKING positions allows the splay angles to expand and contract when assembling and disassembling the array. Moving the pins to the STOW PIN position also keeps them handy so they won't be dropped or misplaced.



TIP: Resist the urge to put the blue locking pins in your pocket. Instead place them in the STOW PIN position before lifting or lowering the array.

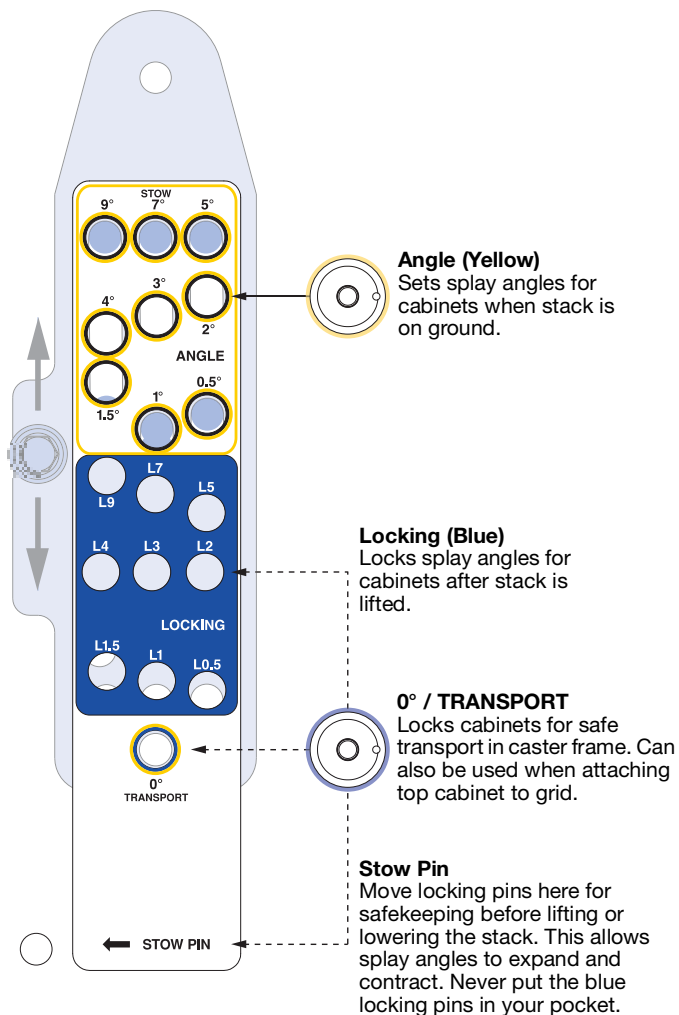



Figure 16: LYON Front GuideALinks Label



NOTE: For more information on GuideALink configurations, refer to the MTG-LYON Assembly Guide (PN 05.232.097.01) available at www.meyersound.com.

CHAPTER 5: RMS REMOTE MONITORING SYSTEM

LYON includes an RMS remote monitoring system module, allowing the loudspeaker to be connected to an RMS network. RMS reports, in real time, the status and power usage of multiple Meyer Sound loudspeakers from a Mac® or Windows®-based computer. The RMServer™ communicates with Meyer Sound loudspeakers equipped with RMS modules. RMServer™ is a compact, Ethernet-based hardware unit with two FT-10 RMS data ports. RMServer stores system configurations internally, eliminating most manual data entry. Systems can be monitored from a computer at front-of-house or backstage, or from a laptop anywhere within the venue over WiFi.

 **NOTE:** For the latest RMS system requirements, visit the Meyer Sound website (<http://www.meyersound.com>).

 **NOTE:** RMS does not control AC power.

COMPASS RMS SOFTWARE

Compass RMS™ software provides extensive system status and performance data for each loudspeaker, including amplifier voltage, limiting activity, power output, fan and driver status, as well as mute and solo capability. Loudspeakers are added to the RMS network and assigned a node name during a one-time discovery procedure. After loudspeakers are identified on the RMS network, they appear in Compass RMS as icons that can be customized to suit your needs (Figure 17).



Figure 17: Compass RMS Window

Individual loudspeakers can be physically identified with the Wink option in RMS, which lights the Wink LED on the RMS module of that particular loudspeaker. Conversely, a loudspeaker can be identified in Compass RMS by pressing the Identify button on the loudspeaker's RMS module.

Loudspeaker icons can be arranged in Compass RMS and saved as pages to represent how the loudspeakers have been deployed in the system. Multiple pages can be saved and recalled for specific performances and venues.

RMS MODULE

The LYON RMS user panel includes an Identify button, Remote Mute switch, Wink/Activity LED, and two Network connectors (Figure 18).

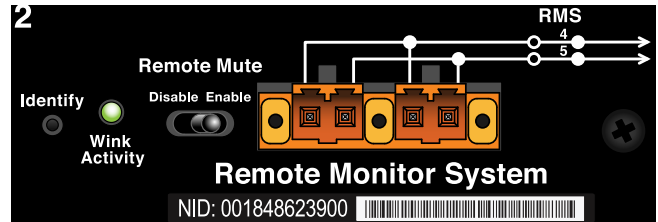



Figure 18: LYON RMS Module

 **NOTE:** The Identify button and Wink/Activity LED on the RMS user panel are used exclusively by RMS and have no effect on the acoustical or electrical activity of the loudspeaker.

Identify Button

The Identify button serves the following functions:

- If the loudspeaker has not yet been discovered on the RMS network (Wink/Activity LED not lit), press the Identify button to discover it.
- To remove the loudspeaker from the RMS network, press and hold the Identify button during startup (see “Resetting the RMS Module” on page 26).
- To *wink* a discovered loudspeaker, press the Identify button. The Wink LED on the loudspeaker icon in Compass RMS lights up and the Wink/Activity LED on the loudspeaker's RMS user panel turns solid green. Press the Identify button again to unwink the loudspeaker.

 **TIP:** The Wink function is useful for identifying the physical loudspeaker corresponding to a loudspeaker icon in Compass RMS.

Wink/Activity LED (Green)

The green Wink/Activity LED indicates the status of the loudspeaker:

- During startup, the LED flashes green 10 times.
- If the loudspeaker has not yet been discovered on the RMS network, the LED is not lit after startup.
- If the loudspeaker has been successfully discovered on the RMS network, the LED flashes green continuously and flashes more rapidly with increased data activity.
- When the loudspeaker is winked, either by clicking the Wink button in Compass RMS or by pressing the Identify button on the RMS user panel, the LED is solid green. The LED remains solid green until the loudspeaker is unwinked.



TIP: The loudspeaker can also be winked by clicking the Wink button on the loudspeaker icon in Compass RMS

Remote Mute Switch

The recessed Remote Mute switch (Figure 19) on the LYON RMS module determines whether Compass RMS can control muting and soloing of the loudspeaker. LYON ships from the factory with the switch enabled.

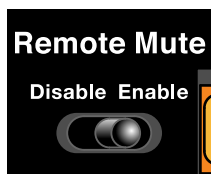

Figure 19: Remote Mute Switch

- **Disable:** When the Remote Mute switch is set to Disable (to the left), the loudspeaker cannot be muted or soloed from Compass RMS.
- **Enable:** When the Remote Mute switch is set to Enable (to the right), the loudspeaker can be muted and soloed from Compass RMS.



NOTE: Compass RMS also allows you to disable Mute and Solo functions to eliminate any possibility of accidentally muting loudspeakers.

RMS Network Connectors

The Weidmuller 2-conductor, locking connectors transfer data to and from the RMS network. Two connectors are provided to allow for easy connection of multiple (daisy-

chained) loudspeakers on the network. Included with each RMS-equipped loudspeaker are RMS cable connectors and mounting blocks for constructing RMS cables. The RMS blocks allow Weidmuller connectors to be securely attached to the RMS module with screws.

NEURON ID FOR RMS MODULE

Each RMS module has a unique 12-character Neuron ID (NID) that identifies the loudspeaker on the network. The NID is automatically detected by RMServer but can also be entered manually, if necessary, when configuring RMS systems in Compass RMS without loudspeakers present. The NID label is located on the RMS user panel near the orange Network connectors.

RESETTING THE RMS MODULE

Use the Identify button to reset the LYON RMS module when powering on the loudspeaker. This action will cause the module to be removed from the RMS network.

To reset the RMS module:

1. Power down the loudspeaker.
2. Press and hold the Identify button.
3. While continuing to hold down the Identify button, power on the loudspeaker.
4. After the Wink/Status LED flashes on and off, release the Identify button. The RMS module is reset and the loudspeaker is removed from the RMS network.

CHAPTER 6: SYSTEM DESIGN AND INTEGRATION TOOLS

This chapter introduces MAPP, Meyer Sound's patented system design tool, the Galileo GALAXY Network Platform, and SIM, a comprehensive system for measurement and analysis.

MAPP SYSTEM DESIGN TOOL

The MAPP System Design Tool (Figure 20) is a powerful, cross-platform application for accurately predicting the coverage pattern, frequency response, phase response, impulse response, and SPL capability of single or arrayed Meyer Sound loudspeakers.

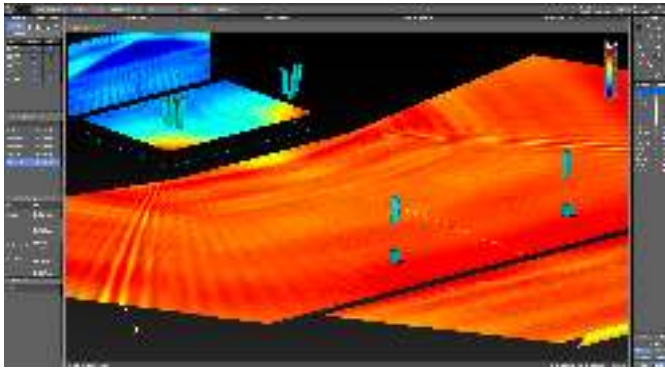

Figure 20: MAPP System Design Tool

Whether planning for fixed installations or for tours with multiple venues, use MAPP to accurately predict the appropriate loudspeaker deployment for each job, complete with coverage data, system delay and equalization settings, rigging information, and detailed design illustrations. MAPP's accurate, high-resolution predictions ensure that systems will perform as expected, thereby eliminating unexpected coverage problems and minimizing onsite adjustments.

The key to the accuracy of MAPP's predictions is Meyer Sound's exhaustive database of loudspeaker measurements. Performance predictions for each loudspeaker are based on 720 1/48th-octave-band measurements taken with a SIM audio analyzer (see "" on page 28) in the Meyer Sound anechoic chamber. The extraordinary consistency between Meyer Sound loudspeakers guarantees that predictions from MAPP will closely match their actual performance.

MAPP client software allows for configuration of Meyer Sound loudspeaker systems and definition of the environment in which they operate, including air temperature, pressure, humidity, and even the location and composition of surfaces. Importation of CAD (.DXF) files containing detailed venue information to act as a visual aid is also possible.

MAPP prediction requests are sent by the client software to Meyer Sound servers, where complex, high-resolution (magnitude and phase) polar data is processed with sophisticated acoustical prediction algorithms. The resulting predictions are then displayed in the MAPP client software.



TIP: Meyer Sound offers seminars and webinars on using MAPP. For more information, visit www.meyersound.com.

MAPP Capabilities

With MAPP, the user can:

- Simulate different loudspeaker configurations to refine system designs and determine the best coverage for intended audience areas
- Model loudspeaker interactions to locate constructive and destructive interferences, so that loudspeakers can be re-aimed and repositioned as necessary
- Place microphones anywhere in the sound field and predict loudspeaker frequency response, phase response, and sound pressure levels at each microphone position
- Determine delay settings for fill loudspeakers using the Inverse Fast Fourier Transform feature
- Preview the results of signal processing to determine optimum settings for the best system response
- Automatically calculate load information for arrays to determine necessary minimum rigging capacity, front-to-back weight distribution, and center of gravity location
- Generate and export system images and full-system PDF reports for client presentations

GALILEO GALAXY NETWORK PLATFORM

The Galileo GALAXY Network Platform is a sophisticated loudspeaker management tool for controlling all Meyer Sound speaker types. The GALAXY loudspeaker processor extends a high level of audio control in driving and aligning loudspeaker systems with multiple zones. It provides a powerful tool set for corrective equalization (EQ) and creative fine-tuning for a full range of applications from touring to cinema.

Users can readily program the GALAXY processor using Compass software running on a host computer or via the Compass Go application for the iPad. Compass Control Software includes custom-designed settings for each family of speakers, as well as to integrate families together. For example, the Product Integration feature matches the phase characteristics between Meyer speaker families to ensure the most coherent summation.

Processing tools for inputs and outputs include delay, parametric EQ and U-Shaping EQ. Output processing also includes polarity reversal, Low-Mid Beam control (LMBC), atmospheric correction, and All Pass filters.

The built-in summing and delay matrices allow a user to easily assign gain and delay values, respectively, at each cross point. This capability greatly facilitates using one loudspeaker to satisfy multiple purposes.

Front panel controls let a user intuitively and quickly operate a GALAXY processor without a computer during live use.

The rear panel includes SIM bus port(s) for direct connection to Meyer Sound's SIM audio analyzer, allowing the GALAXY processor to function as a line switcher for the analyzer. With this capability, a user can take measurements from any selection of GALAXY inputs and outputs without patching beyond a single connection to the analyzer.

The GALAXY 408, GALAXY 816 and GALAXY 816-AES3 processor versions have the same audio processing capability with different I/O. See www.meyersound.com to locate their datasheets for more information.

APPENDIX A: PRODUCT INTEGRATION

Product Integration combines both the Delay Integration setting and the Starting Points setting in a single dialog. By selecting the loudspeaker model in the pop-up window, the Delay Integration and Starting Points drop-down menus are populated with the available options. Using Product Integration is the first step to complete when optimizing a system. It is not recommended for use when a system has previously been optimized, as some or all of the output processing filters and settings may be overwritten.

DELAY INTEGRATION

Delay Integration aligns the phase responses of different loudspeaker model families. Select the product and use the lowest target phase curve frequency: 55-70, 100, or 125 (Hz) that is available for all of the loudspeaker models in a system. Not all products will have every option available, with the exception of 125 Hz.

Figure 21 shows the Frequency and Phase Responses of the LEO (red line) and LYON (brown line) loudspeakers. Note the phase differences, especially between 63 to 125 Hz.

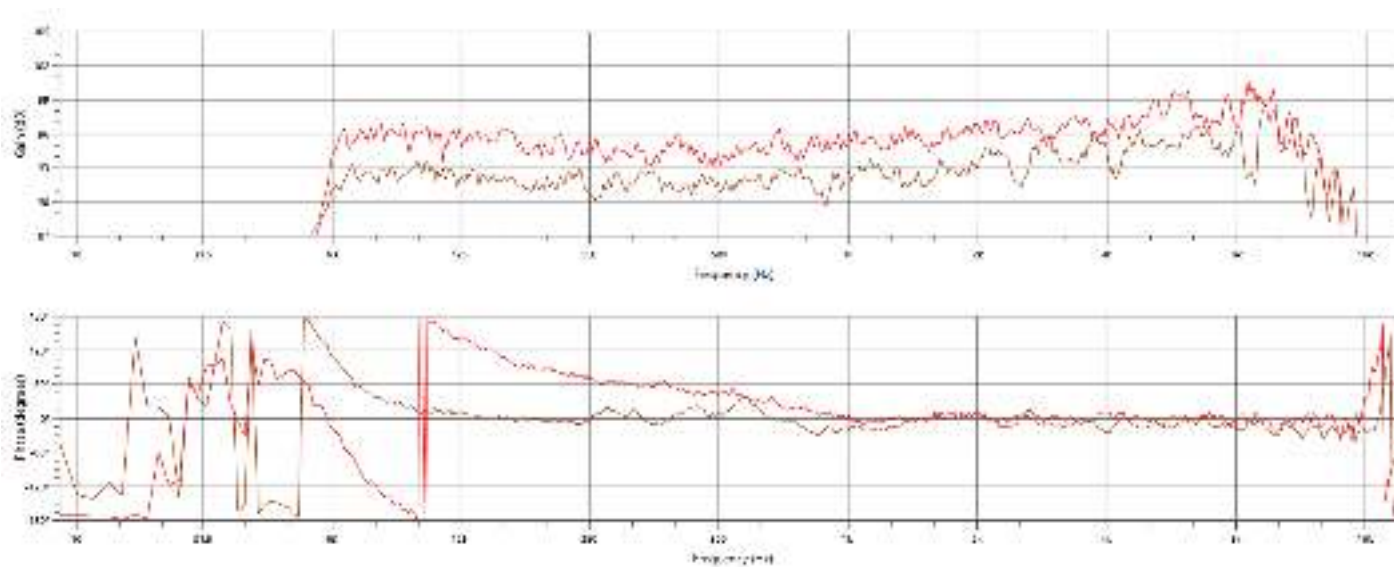

Figure 21: LEO (red) and LYON (brown) Loudspeaker Phase Responses—No Delay Integration

For the example shown in Figure 22, both products (LEO—magenta line, LYON—blue line) have been set to target phase curves with a frequency of 100 Hz (pc100). The phase responses are now much more closely aligned than without Delay Integration.

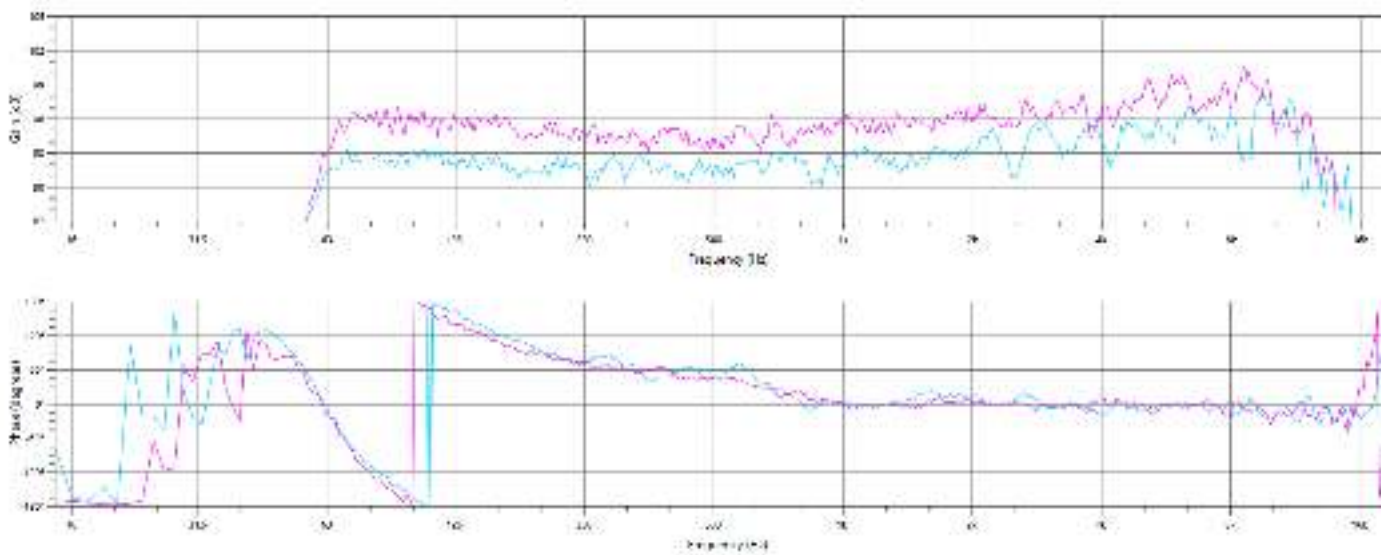

Figure 22: LEO (magenta) and LYON (blue) Loudspeaker Phase Responses-with pc100 Delay Integration

STARTING POINTS

The Starting Points feature lets a user recall files that are saved channel settings. In previous versions of Compass, these files were referred to as Saved Settings. The Starting Points files are created and tested by the factory and are included in the Compass software installation. Additional files can be created and stored by users for later recall.

Factory Starting Points files include two types of settings:

- Line Arrays:

U-Shaping filters are set to adjust the frequency response to a usable result. The response will be close to equal magnitude (flat) for arrays that are 6–8 elements.

There are several options for each model, based on the total splay angle between groups of loudspeakers, starting at the top of the array. Select the Standard option to start. There are angles referred to in the file names, such as 1.5 to 5, which refer to the total splay angle between groups of four loudspeakers.

- Gradient Subwoofer Arrays:

Gradient subwoofer arrays are assembled using groups of elements: forward-facing with rear-facing between them. The Front-Facing selection for most models does not alter the signal processing. The Rear-Facing selection usually inverts the polarity relative to the Front-Facing setting. Delay is also applied to synchronize the output of the rear-facing element with the output of the front-facing elements behind the array.



NOTE: The Starting Points drop-down is populated from the files stored in both of the locations below. The first location is a collection of all files that have been stored on the client computer. The second location contains the current files distributed with Compass. Additional user created files can be created and stored in either location.



NOTE: The software version number on a particular system may differ from what is shown below, but the format of the link will be similar.

MAC OSX:

/Users/user name/CompassGalaxy_Settings/Saved Settings/Starting Points V4.6/GALAXY Starting Points

and

/Applications/Compass v4.6.0/Saved Settings/Starting Points V4.6/GALAXY Starting Points

WIN:

C:\Users\user name\CompassGalaxy_Settings\Saved Settings\Starting Points V4.6\GALAXY Starting Points

and

C:\Program Files (x86)\Meyer Sound\Compass 4.6.0\Saved Settings\Starting Points V4.6\GALAXY Starting Points

APPENDIX B: MEYER SOUND WEATHER PROTECTION

The Weather Protection option from Meyer Sound is intended to increase the useful life of Meyer Sound loudspeakers when they are installed outdoors and exposed to different and often harsh weather conditions.

Meyer Sound Weather Protection includes a penetrating treatment to raw wood, use of special primers, and plating on all steel parts used (or alternatively, the use of stainless steel hardware). Weather Protection is designed to prevent malfunctions caused by harsh operating environments and slows the accelerated wear and tear that occurs in outdoor environments.

When Is Weather Protection Advisable?

Weather Protection is strongly recommended for all permanent outdoor installations where loudspeakers are directly exposed to the elements. This recommendation includes desert and semi-arid climates, where protection against dust and sand is important, and where infrequent rainstorms can contribute to deterioration of loudspeaker components.

Weather Protection is also recommended when the loudspeakers are sheltered from direct exposure to precipitation, but are nevertheless exposed to prolonged high humidity, fog or mist. Examples would be installations on covered outdoor terraces or pavilions.

Weather Protection is further advisable for portable or touring systems when any significant outdoor use is anticipated. Even though standard procedures may call for using external protective measures, these are often not implemented in time to prevent moisture intrusions that could lead to premature performance degradation of the loudspeaker.

Climate Variation and Owner Maintenance

The wear and tear on a loudspeaker will vary significantly with different climatic conditions. For example, a weather-protected loudspeaker installed in a sunlight-exposed location on an ocean pier will experience much harsher conditions than a loudspeaker in a similar installation that is shaded by trees and exposed only to rainfall. The constant exposure to direct UV radiation and a salt air environment will cause a loudspeaker to wear more quickly than one with partial UV shielding and exposed only to freshwater moisture.

Wear can eventually affect the performance of the loudspeaker. It also affects aesthetics. For example, in salt

air environments, the exterior grille can quickly show signs of oxidation, causing unsightly discoloration.

Apart from selecting suitable weather protection, the progress of wear and tear on the loudspeaker can be slowed by a regular schedule of inspection and cleaning. This maintenance is particularly necessary in harsh environments. Inspection and cleaning should include routine removal of any visible oxidation or environmental particulates, as these can accelerate metal corrosion or decay of the cabinet. If installed loudspeakers are not in use for an extended period, exterior protection or temporary removal and storage of the loudspeakers should be considered.

Benefits of Weather Protection

There are several benefits to selecting the Meyer Sound Weather Protection option:

Functionality—Weather Protection prolongs the service life of the loudspeaker by preventing premature degradation of internal components.

Safety—Weather Protection lessens the chance of electrical malfunctions or structural failures.

 **WARNING:** IT IS THE RESPONSIBILITY OF PURCHASERS/USERS/OPERATORS TO SELECT WEATHER PROTECTION WHEN APPROPRIATE FOR THEIR USE AND TO PERIODICALLY INSPECT THEIR LOUDSPEAKER INSTALLATIONS FOR ANY DETERIORATION THAT MAY LEAD TO SAFETY CONCERNS.

Aesthetics—Weather Protection slows wear and tear on the exterior of the loudspeaker in harsh conditions. Early signs of wear and tear on the exterior of the loudspeaker indicate over-exposure to the elements.

Standards Compliance—Weather Protection helps in meeting IP ratings for loudspeakers. IP ratings are an internationally recognized standard often used in installations involving our products. A further explanation of IP ratings is given in the “IP Ratings” Section on page 35.

WEATHER PROTECTION COMPONENTS

Standard Weather Protection

Meyer Sound designs toward an IP rating of IPX4 (see “IP Ratings” on page 35) for Standard Weather Protection, which includes the following components:

- Wood treatment—Prior to cabinet manufacturing, the raw wood receives a special treatment that penetrates and stabilizes the wood fibers to withstand a wide range of temperatures and exposure to extreme humidity.
- Cabinet finishing—The assembled cabinets receive a highly impervious finish that includes a sealing primer and a finishing topcoat. The coatings are applied on both surfaces, with one coat on the interior and two on the exterior. The final step is a two-part modified acrylic urethane similar to that used in military applications.
- Driver treatment—All cone drivers are coated with a water-resistant sealant.
- Exterior protection—Grille frames are coated to resist corrosion, and all components that mount to the cabinet use custom gaskets and stainless steel fasteners.
- Removable rain hood—The rain hood is designed to shield connectors even in wind-driven rain.

If in doubt about an installation method, contact Meyer Sound Technical Support for assistance.

Always discuss the environmental conditions of your Meyer Sound installation with your Sales Manager, and verify the availability of Weather Protection for your selected loudspeaker models. The Sales Manager, together with Technical Support, will verify the appropriate level of weather protection for the loudspeakers and related rigging hardware.

INSTALLATION PRACTICES

Meyer Sound assumes normal and accepted installation practices are used when installing Meyer Sound Loudspeakers outdoors. Deviation from such practices may cause weather protection to be ineffective and void the warranty for the loudspeaker.

Examples of unacceptable and acceptable installation practices include:

- Loudspeakers installed outdoors should not face upward.
- Loudspeakers with a rain hood should be installed in such a way that the rain hood opening is not facing any direction but down.
- Meyer Sound-supplied rigging components should not be modified (for example, by drilling additional holes in a MUB for mounting to a wall). When an installer/integrator modifies a Meyer Sound supplied rigging component to support their installation method, it is considered compromised and out of warranty.
- All loudspeaker cabling must be installed with a “drip-loop” or equivalent method to ensure that rain or water is NOT wicked toward the loudspeaker.

IP RATINGS

IP stands for “Ingress Protection.” The current format for expressing an IP rating is a 2-digit code. The first digit of an IP rating represents protection from solid objects. The second digit of an IP rating represents protection from water or moisture. Table 5 provides a chart of IP ratings and the corresponding definitions of the rating.



NOTE: IP ratings only apply to the “ENCLOSURE.” A loudspeaker is considered an enclosure and as such we can apply an IP rating to it. Rigging hardware is not an enclosure and therefore IP ratings do not apply. Also, cable and cable-mount connectors used to connect to the loudspeaker are NOT part of the enclosure and therefore not part of the IP rating. Only the chassis-mounted part of the connector is considered part of the enclosure.

Table 5: IP Ratings Definition Chart

First Digit (Protection against solid objects)	Definition	Second Digit (Protection against liquids)	Definition
X	Characteristic numeral is not required to be specified.	X	Characteristic numeral is not required to be specified.
0	No protection.	0	No protection.
1	Protected against solid objects over 50 mm.	1	Protected against vertically falling drops of water.
2	Protected against solid objects over 12 mm.	2	Protected against direct sprays up to 15° from the vertical.
3	Protected against solid objects over 2.5 mm.	3	Protected against direct sprays up to 60° from the vertical.
4	Protected against solid objects over 1 mm.	4	Protected against direct sprays from all directions. Limited ingress permitted.
5	Protected against dust. Limited ingress permitted.	5	Protected against low-pressure jets of water from all directions. Limited ingress permitted.
6	Totally protected against dust.	6	Protected against strong jets of water from all directions. Limited ingress permitted.
		7	Protected against the effect of temporary immersion between 15 cm and 1 m.
		8	Protected against the effect of long-term submersion of 1 m or more.

APPENDIX C: RAIN HOODS

LYON loudspeakers are optionally available with weather protection for outdoor installations. Weather-protected LYONs are available with either a collapsible rain hood (Figure 23) for outdoor touring applications or a quick-clip removable rain hood for indoor/outdoor touring and permanent outdoor installations. Both rain hoods protect the loudspeaker's connectors from water intrusion.

LYON COLLAPSIBLE RAIN HOOD

The LYON collapsible rain hood is factory installed and can be expanded when the loudspeaker is installed and collapsed when the loudspeaker is transported. The collapsible rain hood is ideal for outdoor touring applications.

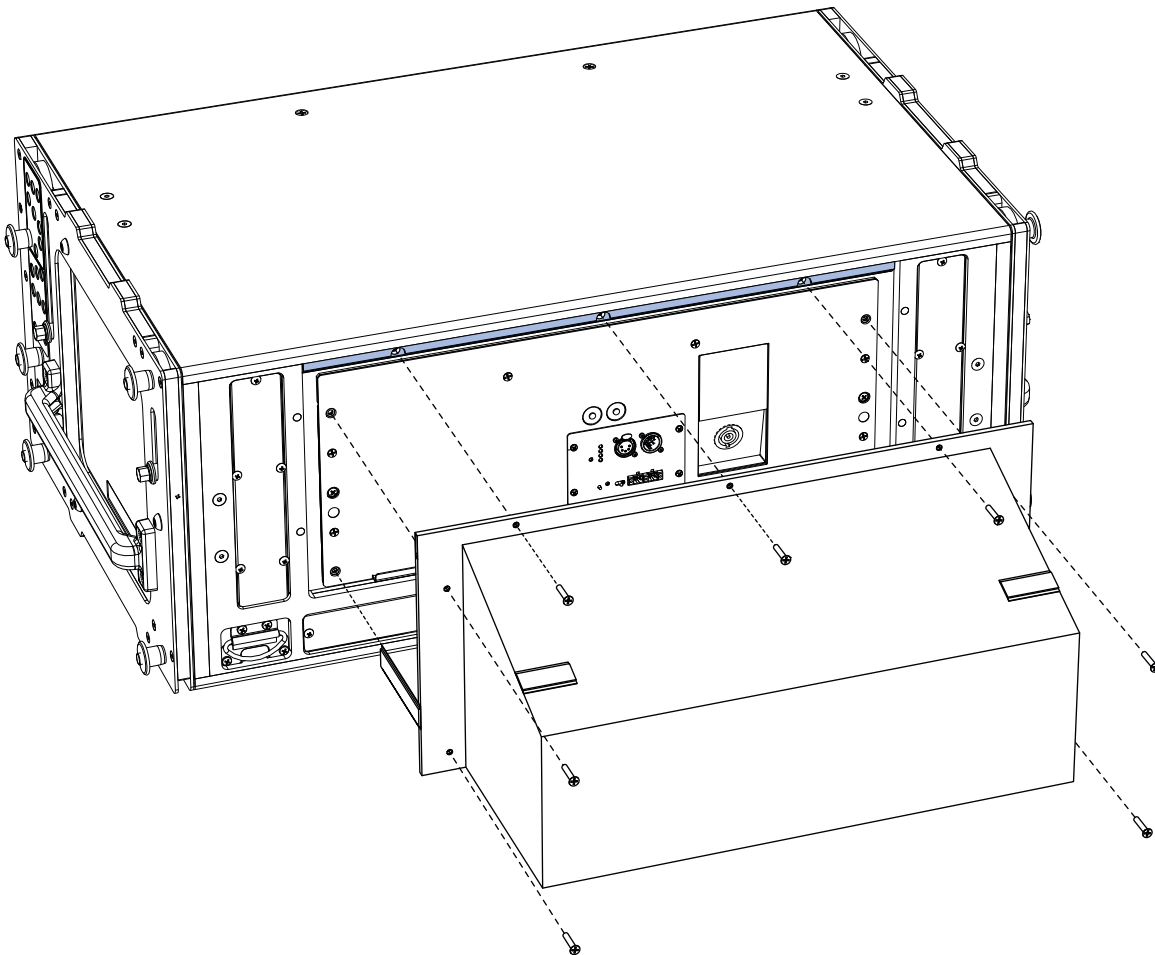

Figure 23: LYON with Collapsible Rain Hood

Expanding the LYON Collapsible Rain Hood

To expand the LYON collapsible rain hood:

1. Remove the rain hood's Velcro straps.
2. Expand the rain hood's fabric fully upward and outward.
3. Reach inside the rain hood and free the two struts from the top corner pockets nearest the loudspeaker (Figure 24).

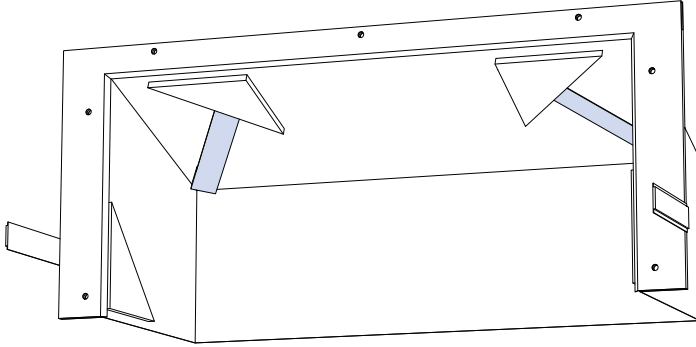

Figure 24: Freeing Rain Hood Struts

4. Fold the two struts downward and outward and insert them into the two side pockets (Figure 25).

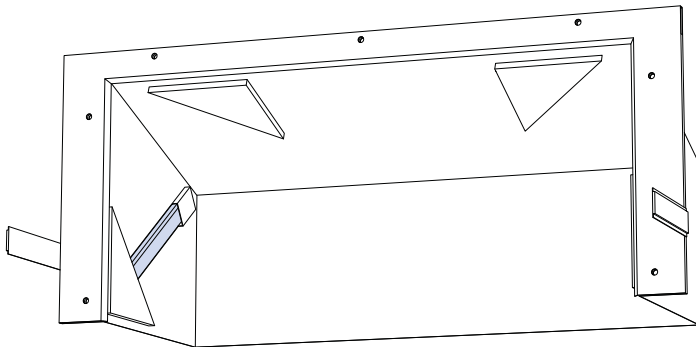

Figure 25: Inserting Rain Hood Struts

LYON QUICK-CLIP RAIN HOOD

The LYON quick-clip removable rain hood (Figure 26) is easily attached and removed with its two winghead studs. The quick-clip rain hood is ideal for indoor/outdoor touring applications and fixed outdoor applications.

To attach the LYON quick-clip rain hood:

1. Connect any required cables to the LYON loudspeaker.
2. Attach the rain hood to the user panel, slipping it under the rain hood retainer flange at the top of the user panel and securing it to the center of the panel with its two winghead studs.

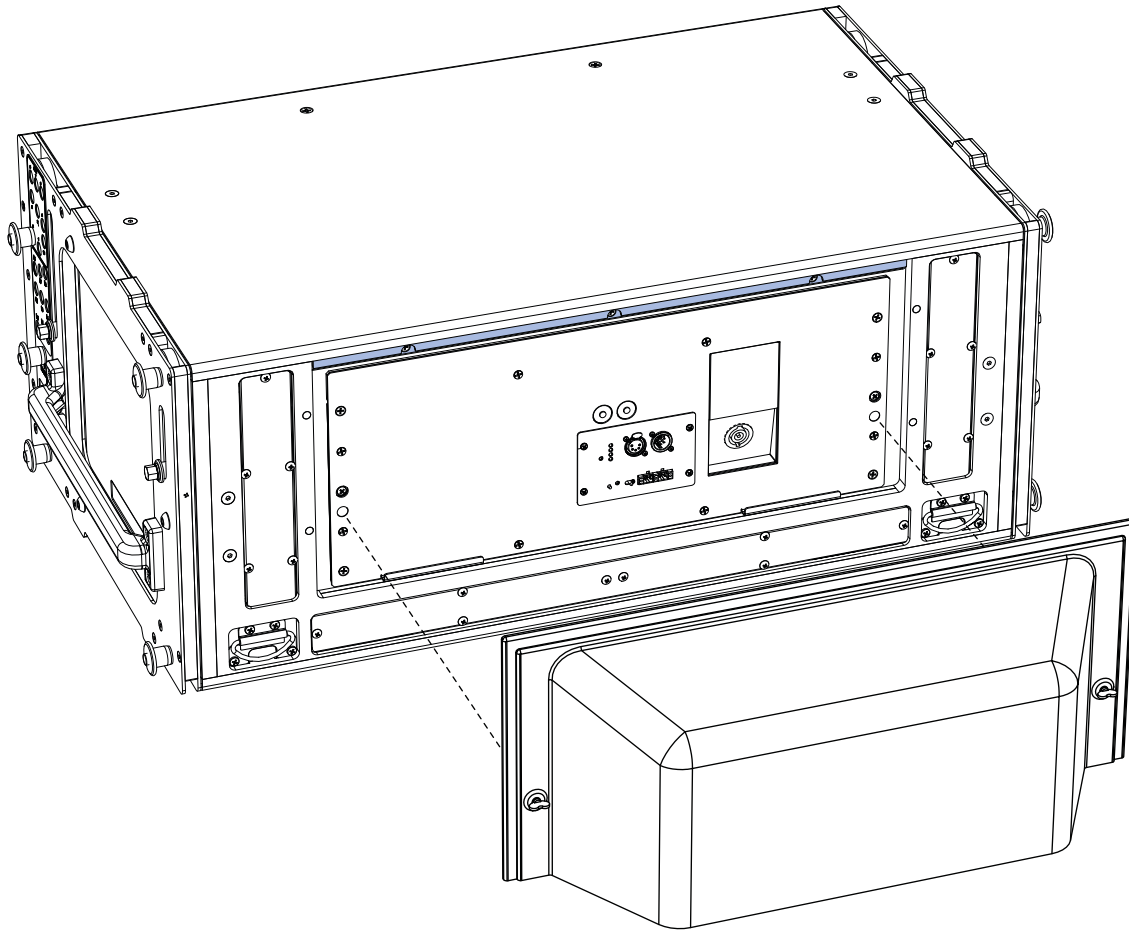

Figure 26: LYON with Quick-Clip Rain Hood

3. Make sure to tighten the winghead studs one quarter turn so they fully lock.

APPENDIX D: SPECIFICATIONS



NOTE: Loudspeaker system predictions for coverage and SPL are available in Meyer Sound's MAPP prediction software.

LYON Specifications

	LYON-M	LYON-W	LYON-WXT
ACOUSTICAL			
Operating Frequency Range	55 Hz – 16.5 kHz Note: Recommended maximum operating frequency range. Response depends on loading conditions and room acoustics.		
Phase Response	80 Hz to 16 kHz $\pm 30^\circ$		
Linear Peak SPL	143.5 dB with crest factor >17.5 dB (M-noise), 137.5 dB (Pink Noise), 140 dB (B-noise)	143.5 dB with crest factor >17.5 dB (M-noise), 136.5 dB (Pink Noise), 138.5 dB (B-noise)	143.5 dB with crest factor >17.5 dB (M-noise), 136.5 dB (Pink Noise), 138.5 dB (B-noise)
	<p>Note: Linear Peak SPL is measured in free-field at 4 m referred to 1 m. Loudspeaker SPL compression measured with M-noise at the onset of limiting, 2-hour duration, and 50-degree C ambient temperature is <2 dB.</p> <p>M-noise is a full bandwidth (10 Hz–22.5 kHz) test signal developed by Meyer Sound to better measure the loudspeaker's music performance. It has a constant instantaneous peak level in octave bands, a crest factor that increases with frequency, and a full bandwidth Peak to RMS ratio of 18 dB. The presence of a greater-than (>) symbol with regard to crest factor indicates it may be higher depending on EQ and boundary loading.</p> <p>Pink noise is a full bandwidth test signal with Peak to RMS ratio of 12.5 dB.</p> <p>B-noise is a Meyer Sound test signal used to ensure measurements reflect system behavior when reproducing the most common input spectrum, and to verify there is still headroom over pink noise.</p>		
COVERAGE			
Horizontal Coverage	90°	110°	110°
Vertical Coverage	Varies, depending on array length and configuration; LYON-WXT has extended vertical coverage.		
TRANSDUCERS			
Low Frequency	Two 12-inch long-excursion cone drivers; 4 Ω nominal impedance		
High Frequency	Two 3-inch compression drivers coupled to a constant-directivity horn through a patented REM [®] manifold; 16 Ω nominal impedance.		
AUDIO INPUT			
Type	Differential, electronically balanced		
Maximum Common Mode Range	± 15 V DC, clamped to earth for voltage transient protection		
Connectors	XLR 5-pin female with male loop output; XLR 3-pin female connectors available to accommodate only balanced audio (no RMS signals)		
Input Impedance	10 k Ω differential between pins 2 and 3		
Wiring	Pin 1: Chassis/earth through 1 k Ω , 1000 pF, 15 V clamped network to provide virtual ground lift at audio frequencies Pin 2: Signal (+) Pin 3: Signal (-) Pin 4: RMS (polarity insensitive) Pin 5: RMS (polarity insensitive) Case: Earth ground and chassis Note: Pins 4 and 5 (RMS) included only with XLR 5-pin connector that accommodates both balanced audio and RMS signals.		
Nominal Input Sensitivity	0.0 dBV (1.0 V rms) continuous is typically the onset of limiting for noise and music		

LYON Specifications

Input Level	Audio source must be capable of producing +20 dBV (10 V rms) into 600 Ω to produce the maximum peak SPL over the operating bandwidth of the loudspeaker	
AMPLIFIER		
Type	3-channel, complementary MOSFET output stages (class AB/H bridged)	
Total Output Power	8500 W peak Note: Peak power based on the maximum unclipped voltage the amplifier will produce into the nominal load impedance.	
THD, IM, TIM	< 0.02%	
Cooling	Two ultra high-speed primary fans, two ultra high-speed reserve fans	
AC POWER		
Connector	powerCON 32 input	
Voltage Selection	Automatic, two ranges, each with high-low voltage tap (uninterrupted)	
Safety Agency Rated Voltage Range	95–125 V AC; 208–235 V AC, 50–60 Hz	
Turn-on/off Points	Turn-on: 85 V AC; Turn-off: 134 V AC Turn-on: 165 V AC; Turn-off: 264 V AC	
CURRENT DRAW		
Idle	1.2 A rms (115 V AC); 0.6 A rms (230 V AC); 0.7 A rms (208 V AC)	
Maximum Long-Term Continuous (> 10 sec)	11.2 A rms (115 V AC); 5.6 A rms (230 V AC); 6.2 A rms (208 V AC)	
Burst (< 1 sec)	15.4 A rms (115 V AC); 7.5 A rms (230 V AC); 8.2 A rms (208 V AC) Note: AC power cabling must be of sufficient gauge so that under burst rms current conditions, cable transmission losses do not cause the loudspeaker's voltage to drop below the specified operating range.	
Maximum Instantaneous Peak	45 A peak (115 V AC); 23 A peak (230 V AC); 25 A peak (208 V AC)	
Inrush	<15 A peak	
RMS NETWORK		
	Equipped with two-conductor twisted-pair network; reports all operating parameters of amplifiers to host computer.	
PHYSICAL		
Enclosure	Premium multi-ply birch	
Finish	Slightly textured black	
Protective Grille	Powder-coated, hex-stamped steel with acoustical black mesh	
Rigging	End frames with captive GuideALinks secured with 0.4375 in x 0.090 in quick-release pins that allow 0.5° to 9.0° splay angles (8° to 15° splay angles supported with LYON-WXT); detachable side handles	
Dimensions	W: 38.15 inches (969 mm) x H: 14.85 inches (377 mm) x D: 21.00 inches (533 mm)	
Weight	199 lb (90.3 kg)	
ENVIRONMENTAL		
Operating Temperature	0 °C to +45 °C	
Non Operating Temperature	-40 °C to +75 °C	
Humidity	To 95% at 45 °C (non-condensing)	
Operating Altitude	To 5,000 m (16,404 ft)	
Non Operating Altitude	To 12,000 m (39,000 ft)	
Shock	30 g 11 msec half-sine on each of 6 sides	
Vibration	10 Hz – 55 Hz (0.010 m peak-to-peak excursion)	

LYON-M DIMENSIONS

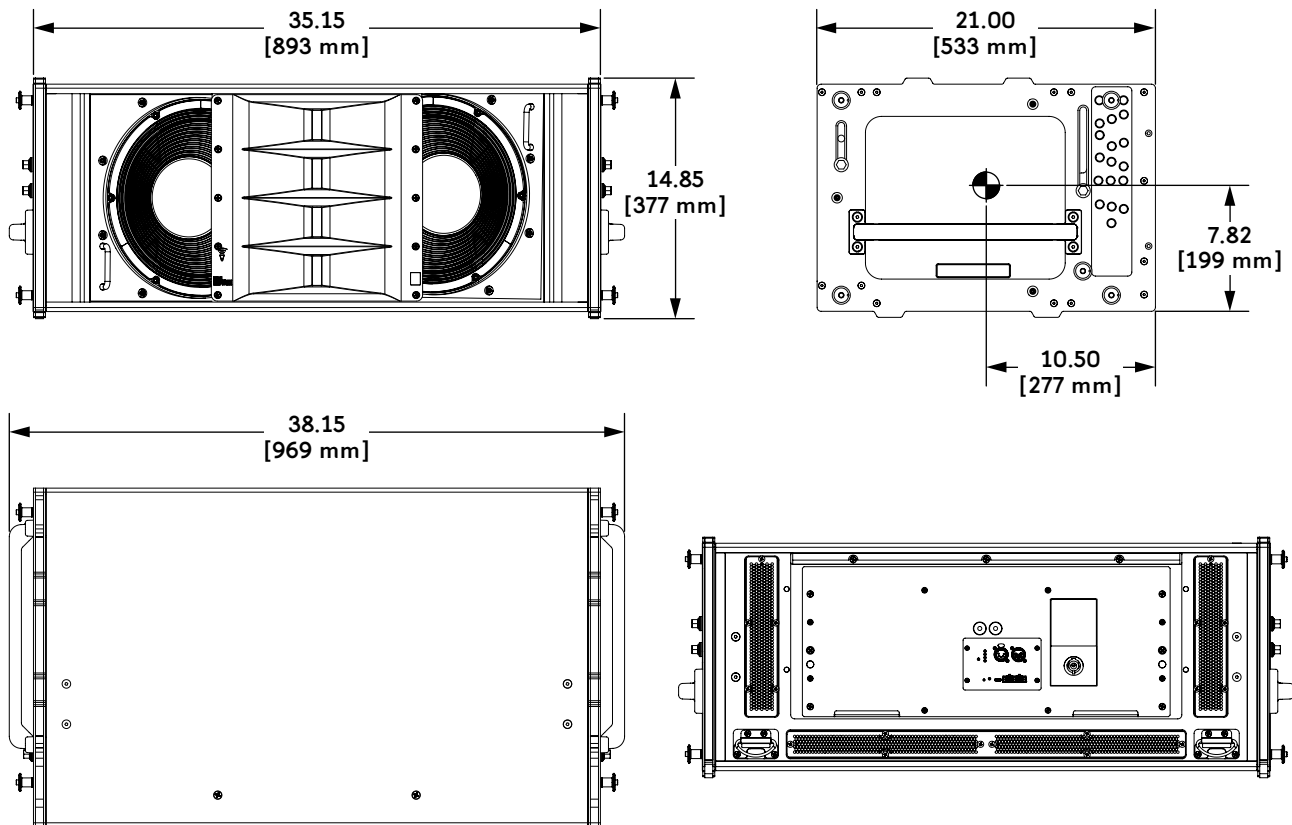

LYON-M Dimensions



NOTE: For the dimensions and weight for the MTG-LYON top grid and MCF-LYON caster frame, refer to the MTG-LYON Assembly Guide (PN 05.232.097.01) available at www.meyersound.com.

LYON-W, LYON-WXT DIMENSIONS

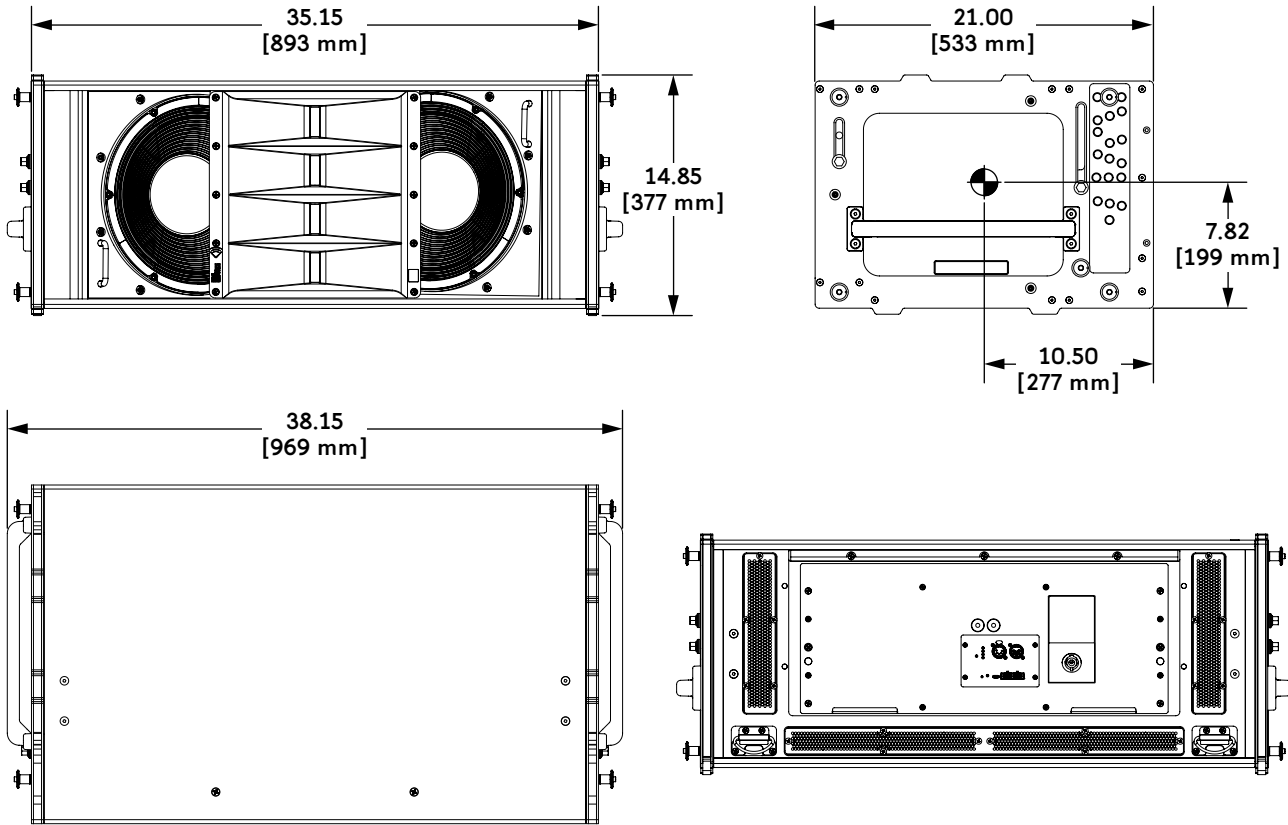

LYON-W Dimensions



NOTE: For the dimensions and weight for the MTG-LYON top grid and MCF-LYON caster frame, refer to the MTG-LYON Assembly Guide (PN 05.232.097.01) available at www.meyersound.com.

FEDERAL COMMUNICATIONS COMMISSION (FCC) STATEMENT

This equipment has been tested and found to comply with the limits for a Class A digital device, pursuant to part 15 of the FCC Rules. These limits are designed to provide reasonable protection against harmful interference when the equipment is operated in a commercial environment. This equipment generates, uses, and can radiate radio frequency energy and, if not installed and used in accordance with the instruction manual, may cause harmful interference to radio communications. Operation of this equipment in a residential area is likely to cause harmful interference in which case the user will be required to correct the interference at their own expense.

This device complies with Part 15 of the FCC rules. Operation is subject to the following two conditions: (1) this device may not cause harmful interference, and (2) this device must accept any interference received, including interference that may cause undesired operation.

INDUSTRY CANADA COMPLIANCE STATEMENT

This Class A digital apparatus complies with Canadian ICES-003.

AVIS DE CONFORMITÉ À LA RÉGLEMENTATION D'INDUSTRIE CANADA

Cet appareil numérique de la classe A est conforme à la norme NMB-003 du Canada.

EN 55032 (CISPR 32) STATEMENT

Warning: This equipment is compliant with Class A of CISPR 32. In a residential environment this equipment may cause radio interference.



Meyer Sound Laboratories Inc.
2832 San Pablo Avenue
Berkeley, CA 94702
+1 510 486.1166
meyersound.com

© 2014–2020
Meyer Sound Laboratories Inc. All rights reserved.
LYON Operating Instructions
PN 05.232.005.01 B3