

# MM-10 : Miniature Subwoofer



The MM-10 miniature subwoofer delivers expanded low frequency for applications that require excellent audio quality from a compact system. Designed primarily as a companion to Meyer Sound’s MM-4XP miniature loudspeaker, as well as the UP-4XP ultracompact loudspeaker, the MM-10 allows system designers to create full-range systems where space limitations are a concern.

The MM-10 features an operating frequency range of 33 Hz to 228 Hz with a conservatively rated maximum peak SPL of 123 dB. The MM-10 bass reflex cabinet houses a single 10-inch driver and a single-channel power amplifier complete with onboard processing, including a crossover, driver protection, and frequency and phase correction. The built-in crossover accepts full-range signals, facilitating basic daisy-chaining for signal distribution, eliminating the need for external crossovers in small setups.

The MM-10 subwoofer is available from the factory in three models — the MM-10XP, MM-10AC, and MM-10ACX — each offering different internal configurations and audio and power connectors (which cannot be upgraded).

The MM-10XP model is powered by an external 48 V DC power supply, eliminating the need for wiring conduits while still preserving

the advantages of self-powered loudspeaker systems. The unit’s onboard amplifier and signal-processing circuits were designed to store DC power and tolerate voltage drops, thereby accommodating light-gauge cables and lengthy cable runs. The MM-10XP is available with either a Phoenix™ 5-pin male or sealed SwitchCraft® EN3™ male connector for receiving balanced audio and DC power. The EN3 connector is ideal for outdoor, all-weather use.

MM-10XPs require an MPS-488 external power supply. The single-space 19-inch rack unit receives balanced audio from its XLR female inputs and routes the audio, along with 48 V of DC power, to its channel outputs. The channel outputs — equipped with either Phoenix 5-pin male connectors or EN3 5-pin female connectors — can deliver DC power to up to four MM-10XP subwoofers at cable lengths of up to 150 feet with just 1 dB of loss in peak SPL using 18 AWG wire. The use of composite multiconductor cables (such as Belden® 1502) allows a single cable to carry both DC power and balanced audio to the MM-10XPs. Longer cable runs are possible for moderate applications that don’t drive the subwoofers to maximum output, or for installations with heavier wire gauges.

The MM-10AC model is ideal for fixed installations and portable applications where

AC power is readily available to power the unit. The MM-10AC includes an internal power supply and locking PowerCon® connectors for AC input and AC loop output (for powering additional MM-10AC subwoofers). The MM-10AC receives audio from an XLR female input, and also includes an XLR male loop output for daisy-chaining audio signals.

The MM-10ACX model includes onboard DC power and audio routing for driving a pair of MM-4XP miniature loudspeakers, or a single UP-4X ultracompact loudspeaker, effectively placing the MM-10ACX at the heart of an extremely capable compact, full-range loudspeaker system. Three XLR female inputs are included for receiving audio independently for the subwoofer and satellite loudspeakers. The two output connectors for the satellite loudspeakers are available with Phoenix 5-Pin male or EN3 5-pin female connectors. In addition, a two-channel signal can be patched to the satellite inputs and summed and routed to the subwoofer with the input select switch.

Other options for all MM-10 models include the MUB-MM10 U-bracket for mounting the subwoofer on ceilings and walls; weather protection, complete with rain hoods, for outdoor, all-weather use; and custom color finishes for installations and applications with specific cosmetic requirements.

## FEATURES & BENEFITS

- Powerful low-frequency response from a very small cabinet
- Low distortion affords exceptionally clean bass
- Adaptable to complement MM-4XP and UP-4XP loudspeakers
- Versions include 48 V DC external power supply or built-in AC power for driving satellite loudspeakers

## APPLICATIONS

- Background music
- Small theatres
- Portable AV systems
- Compact voice reinforcement systems

# MM-10 ARCHITECT SPECIFICATIONS (ALL MODELS)

The loudspeaker shall be a self-powered, sub-bass system with one 10-inch cone driver (with a 2-inch voice coil) rated to handle 400 watts. The loudspeaker shall incorporate internal processing electronics and a single-channel class D amplifier. Processing functions shall include equalization, phase correction, signal division, and driver protection. Amplifier output power shall be 220 W (440 W peak). Distortion (THD, IM, TIM) shall not exceed 0.02%.

Performance specifications for a typical production unit shall be as follows, measured at 1/3-octave resolution: operating frequency range, 33 Hz to 228 Hz; phase response,  $\pm 45^\circ$  from 38 Hz to 138 Hz; maximum peak SPL, 123 dB at 1 meter, measured free field. Coverage shall be 360 degrees.

Loudspeaker components shall be mounted in a cabinet constructed of multi-ply hardwood with a black textured finish.

Its front protective grille shall be hex-stamped steel with black mesh screen. Dimensions for the loudspeaker shall be 19" wide x 11" high x 12" deep (482 mm x 279 mm x 305 mm). Weight shall be 27 lbs (12.25 kg).

The loudspeakers shall be the Meyer Sound MM-10XP, MM-10AC, or MM-10ACX.

## MM-10XP

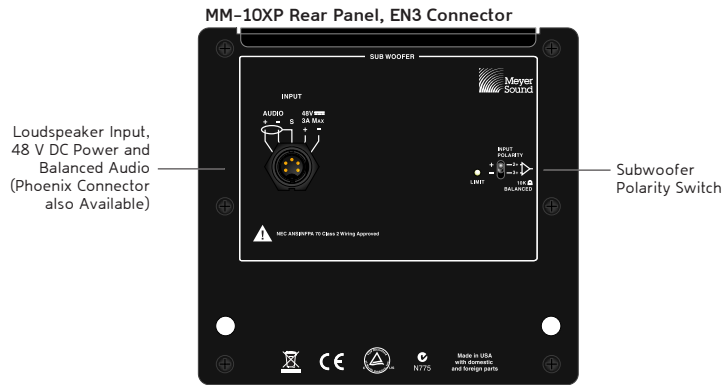

The loudspeaker shall be equipped with either a Phoenix 5-pin male or EN3 5-pin male connector (three pins for balanced audio and two pins for DC power). The audio input shall be electronically balanced with a 10-kOhm impedance and accept a nominal  $-2.0$  dBV (0.8 V rms, 1.1 V peak) input signal. DC blocking and RF filtering shall be provided, and CMRR shall be greater than 50 dB and typically 80 dB (50 Hz to 500 Hz).

Power requirements for the loudspeaker shall be a Meyer Sound MPS external power supply capable of delivering 48 V DC. Current draw during burst ( $< 1$  sec) shall be 2.5 A rms at 48 V DC; current inrush during turn-on shall not exceed 7.0 A peak at 48 V DC.

The loudspeaker shall be the Meyer Sound MM-10XP.

## MM-10AC

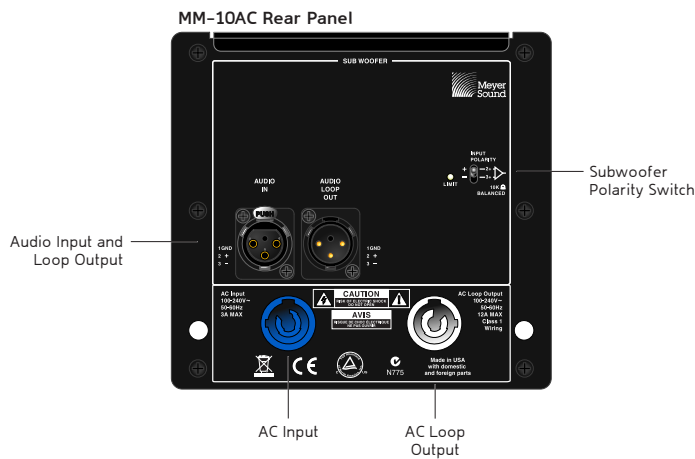

The audio input shall be electronically balanced with a 10-kOhm impedance and accept a nominal  $-2.0$  dBV (0.8 V rms, 1.1 V peak) input signal. Connectors shall be XLR female for input and XLR male for loop output. DC blocking and RF filtering shall be provided, and CMRR shall be greater than 50 dB and typically 80 dB (50 Hz to 500 Hz).

Power requirements shall be nominal 100 V, 110 V, or 230 V AC line current at 50 Hz or 60 Hz. UL and CE operating voltage ranges shall be 100 to 240 V AC. AC power connectors shall be PowerCon with looping output. Current draw during burst ( $< 1$  sec) shall be 0.9 A rms at 115 V, 0.4 A rms at 230 V AC, and 1.1 A peak at 100 V AC; current inrush during turn-on shall not exceed 4.0 A rms at 115 V AC, 2.4 A rms at 230 V AC, and 4.0 A peak at 100 V AC.

The loudspeaker shall be the Meyer Sound MM-10AC.

## MM-10ACX

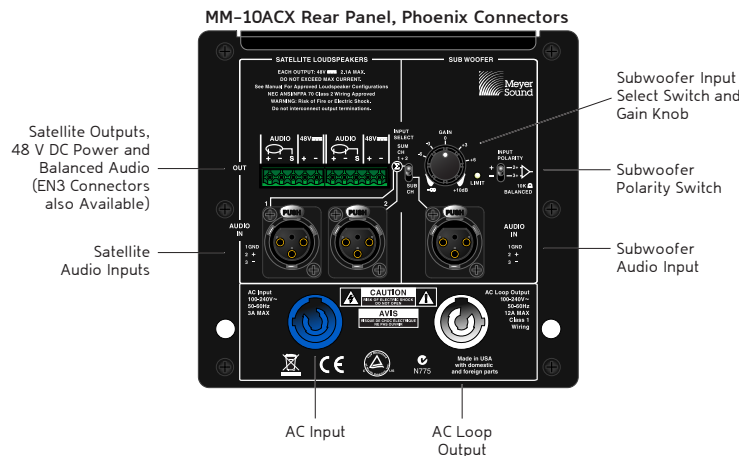

The audio input shall be electronically balanced with a 10-kOhm impedance and accept a nominal  $-2.0$  dBV (0.8 V rms, 1.1 V peak) input signal. Three XLR female input connectors shall be provided, one for the subwoofer and two for satellite loudspeakers. DC blocking and RF filtering shall be provided, and CMRR shall be greater than 50 dB and typically 80 dB (50 Hz to 500 Hz). Two output connectors shall be provided for routing balanced audio and 48 V of DC power to the satellite loudspeakers.

Satellite output connectors shall be either Phoenix 5-pin male or EN3 5-pin female (three pins for balanced audio, two pins for DC power). An input select switch shall determine whether the subwoofer receives its source from the subwoofer input or from the satellite inputs (summed). The subwoofer output shall be adjusted with a gain control.

Power requirements shall be nominal 100 V, 110 V, or 230 V AC line current at 50 Hz or 60 Hz. UL and CE operating voltage range shall be 100 to 240 V AC. AC power connectors shall be PowerCon with looping output. Current draw during burst ( $< 1$  sec) shall be 1.1 A rms at 115 V, 0.6 A rms at 230 V AC, and 1.3 A peak at 100 V AC; current inrush during turn-on shall not exceed 6.6 A rms at 115 V AC, 3.7 A rms at 230 V AC, and 7.2 A peak at 100 V AC.

The loudspeaker shall be the Meyer Sound MM-10ACX.

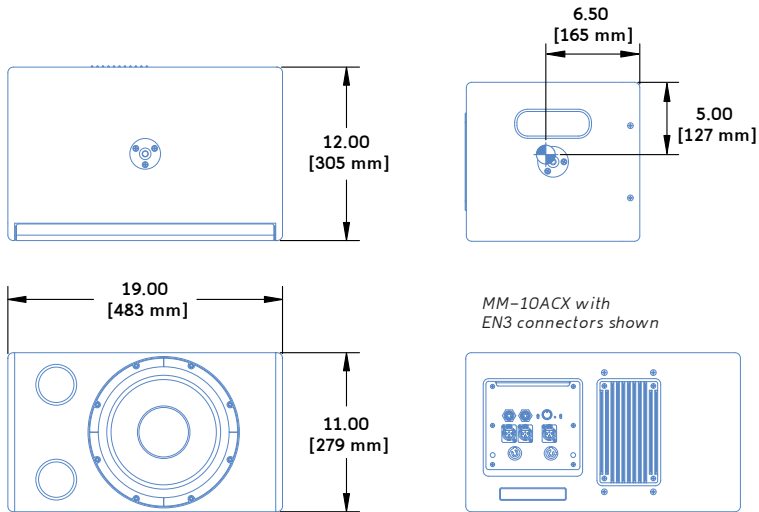

- Dimensions** 19" w x 11" h x 12" d  
(482 mm x 279 mm x 305 mm)
- Weight** 27 lbs (12.25 kg)
- Enclosure** Multi-ply hardwood
- Finish** Black textured
- Protective Grille** Hex-stamped steel with black mesh screen

## MM-10 RIGGING

Top and side nut plates available with 3/8" or M10 threads. The MUB-MM10 U-bracket mounts the MM-10 on walls and ceilings at adjustable angles.

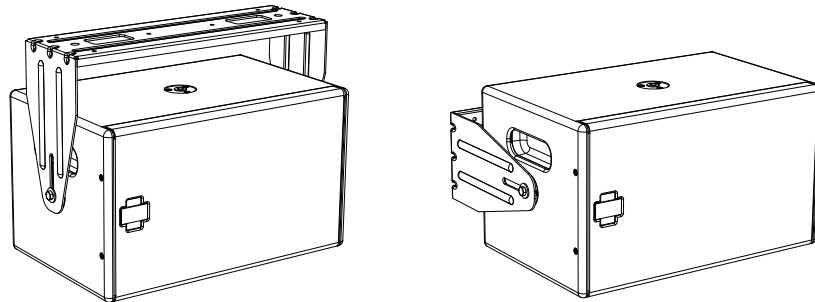

## MM-10 SPECIFICATIONS (ALL MODELS)

<b>ACOUSTICAL</b>	<ul style="list-style-type: none"> <li>Operating Frequency Range<sup>1</sup> 33 Hz – 228 Hz</li> <li>Frequency Response<sup>2</sup> 35 Hz – 208 Hz ±4 dB</li> <li>Phase Response 38 Hz – 138 Hz ±45°</li> <li>Maximum Peak SPL<sup>3</sup> 123 dB</li> <li>Dynamic Range &lt; 100 dB</li> </ul>
<b>COVERAGE</b>	360°
<b>TRANSDUCER</b>	<ul style="list-style-type: none"> <li>Type 10" cone driver with neodymium magnet</li> <li>Nominal Impedance 4 Ω</li> <li>Voice Coil Size 2"</li> <li>Power Handling 400 W (AES)<sup>4</sup></li> </ul>
<b>AUDIO INPUT</b>	<ul style="list-style-type: none"> <li>Type Differential, electronically balanced</li> <li>Maximum Common Mode Range ±5 V DC</li> <li>Input Impedance 10 kΩ electronically balanced</li> <li>DC Blocking 4.8 Hz high pass</li> <li>CMRR &lt; -60 dB, typically &lt; -72 dB (200 Hz – 3 kHz)</li> <li>RF Filter Common mode: 616 kHz</li> <li>Differential mode: 616 kHz</li> <li>Nominal Input Sensitivity -2.0 dBV (0.8 V rms, 1.1 V peak) continuous is typically the onset of limiting for noise and music</li> <li>Input Level Audio source must be capable of producing +16 dBV (6.3 V rms, 9.0 V peak) into 600 Ω to produce the maximum peak SPL over the operating bandwidth of the loudspeaker</li> </ul>
<b>AMPLIFIER</b>	<ul style="list-style-type: none"> <li>Type Class D</li> <li>Output Power<sup>5</sup> 220 W</li> <li>Total Output 440 W peak</li> <li>THD, IM, TIM &lt; .02%</li> <li>Load Capacity 4 Ω</li> <li>Cooling Convection</li> </ul>

### NOTES:

1. Recommended maximum operating frequency range. Response depends on loading conditions and room acoustics.
2. Free field, measured with 1/3-octave frequency resolution at 4 meters.
3. Measured with music referred to 1 meter.
4. Power handling measured under AES standards: transducer driven continuously for two hours with a band-limited noise signal having a 6 dB peak-average ratio.
5. Amplifier wattage rating based on the maximum unclipped burst sine-wave rms voltage the amplifier will produce into the nominal load impedance: 30 V rms (42 V peak) into 4 ohms.

## MM-10XP SPECIFICATIONS

<b>MM-10XP REAR PANEL</b>	
<b>Audio/Power Connector</b>	Phoenix 5-pin male or EN3 5-pin male (two pins for DC power, three pins for balanced audio)
<b>Wiring</b>	Pin 1: DC power negative (-) Pin 2: DC power positive (+) Pin 3: Balanced audio shield, chassis/earth Pin 4: Balanced audio (-) Pin 5: Balanced audio (+)
<b>Input Polarity Switch</b>	Reverses audio input polarity between pins 4 and 5
<b>LED</b>	Displays loudspeaker status
<b>MM-10XP DC POWER</b>	
<b>Safety Agency Rated Operating Range<sup>6</sup></b>	48 V DC
<b>Current Draw:</b>	
<b>Idle Current</b>	0.16 A rms
<b>Max. Long-Term Continuous Current (&gt;10 sec)</b>	0.90 A rms
<b>Burst Current (&lt;1 sec)</b>	2.5 A rms
<b>Ultimate Short-Term Peak Current</b>	3.0 A peak
<b>Inrush Current</b>	< 7.0 A peak
<b>MPS-488 Power Supply Required</b>	
	For information and specifications for the Meyer Sound MPS-488 external power supply, refer to its datasheet.

## MM-10AC SPECIFICATIONS

<b>MM-10AC REAR PANEL</b>	
<b>Audio Connectors</b>	XLR female input with XLR male loop output <sup>7</sup> Pin 1: Chassis/earth through 220 k $\Omega$ , 1000 pF, 15 V clamp network to provide virtual ground lift at audio frequencies Pin 2: Signal + Pin 3: Signal - Case: Earth ground and chassis
<b>Input Polarity Switch</b>	Reverses audio input polarity between pins 2 and 3
<b>AC Power Connectors</b>	PowerCon with loop output
<b>LED</b>	Displays loudspeaker status
<b>MM-10AC AC POWER</b>	
<b>Voltage Selection</b>	Automatic
<b>Safety Agency Rated Operating Range</b>	100–240 V AC, 50/60 Hz
<b>Turn-on and Turn-off Points<sup>8</sup></b>	90–264 V AC, 50/60 Hz
<b>Current Draw:<sup>9</sup></b>	
<b>Idle Current</b>	0.13 A rms (115 V AC); 0.13 A rms (230 V AC); 0.14 A rms (100 V AC)
<b>Max. Long-Term Continuous Current (&gt;10 sec)</b>	0.40 A rms (115 V AC); 0.25 A rms (230 V AC); 0.46 A rms (100 V AC)
<b>Burst Current (&lt;1 sec)</b>	0.9 A rms (115 V AC); 0.4 A rms (230 V AC); 1.1 A rms (100 V AC)
<b>Ultimate Short-Term Peak Current</b>	2.0 A peak (115 V AC); 1.4 A peak (230 V AC); 2.3 A peak (100 V AC)
<b>Inrush Current</b>	4.0 A peak (115 V AC); 2.4 A peak (230 V AC); 4.0 A peak (100 V AC)

## MM-10ACX SPECIFICATIONS

<b>MM-10ACX REAR PANEL</b>	
<b>Subwoofer Audio Connector</b>	XLR female input Pin 1: Chassis/earth through 220 k $\Omega$ , 1000 pF, 15 V clamp network to provide virtual ground lift at audio frequencies Pin 2: Signal + Pin 3: Signal - Case: Earth ground and chassis
<b>Input Polarity Switch</b>	Reverses audio input polarity between pins 2 and 3 (subwoofer only)
<b>Input Select Switch<sup>10</sup></b>	Determines whether the subwoofer receives its source signal from the subwoofer input or satellite inputs (summed)
<b>Gain Knob<sup>11</sup></b>	Adjusts the subwoofer signal from completely attenuated to +10 dB
<b>AC Power Connectors</b>	PowerCon with loop output
<b>Satellite Loudspeaker Connectors<sup>12</sup></b>	Two XLR female inputs Two Phoenix 5-pin male or EN3 5-pin female outputs (two pins for DC power, three pins for balanced audio)
<b>LED</b>	Displays loudspeaker status
<b>MM-10ACX AC POWER</b>	
<b>Voltage Selection</b>	Automatic
<b>Safety Agency Rated Operating Range</b>	100–240 V AC, 50/60 Hz
<b>Turn-on and Turn-off Points<sup>13</sup></b>	90–264 V AC, 50/60 Hz
<b>Current Draw (Subwoofer Only):<sup>14</sup></b>	
<b>Idle Current</b>	0.21 A rms (115 V AC); 0.20 A rms (230 V AC); 0.23 A rms (100 V AC)
<b>Max. Long-Term Continuous Current (&gt;10 sec)</b>	0.48 A rms (115 V AC); 0.31 A rms (230 V AC); 0.55 A rms (100 V AC)
<b>Burst Current (&lt;1 sec)</b>	1.1 A rms (115 V AC); 0.6 A rms (230 V AC); 1.3 A rms (100 V AC)
<b>Ultimate Short-Term Peak Current</b>	2.2 A peak (115 V AC); 1.6 A peak (230 V AC); 2.5 A peak (100 V AC)
<b>Inrush Current</b>	6.6 A peak (115 V AC); 3.7 A peak (230 V AC); 7.2 A peak (100 V AC)
<b>Current Draw (with Two MM-4XPs):<sup>15</sup></b>	
<b>Idle Current</b>	0.32 A rms (115 V AC); 0.26 A rms (230 V AC); 0.36 A rms (100 V AC)
<b>Max. Long-Term Continuous Current (&gt;10 sec)</b>	0.90 A rms (115 V AC); 0.51 A rms (230 V AC); 1.02 A rms (100 V AC)
<b>Burst Current (&lt;1 sec)</b>	2.5 A rms (115 V AC); 1.3 A rms (230 V AC); 3.0 A rms (100 V AC)
<b>Ultimate Short-Term Peak Current</b>	4.5 A peak (115 V AC); 2.8 A peak (230 V AC); 5.0 A peak (100 V AC)
<b>Inrush Current</b>	7.6 A peak (115 V AC); 4.4 A peak (230 V AC); 8.4 A peak (100 V AC)

### NOTES:

- Tolerates voltage drops up to 30% with long cable runs.
- Audio loop output only included on the MM-10AC model.
- No automatic turn-off voltages. Voltages above 265 V AC are fuse protected but may cause permanent damage to the power supply. Voltages below 90 V AC may result in intermittent operation.
- Current draw values for a single MM-10AC. AC Loop output not used.
- Input Select switch only included on the MM-10ACX model.
- Gain knob only included on the MM-10ACX model.
- Satellite loudspeaker connectors only included on the MM-10ACX model.
- No automatic turn-off voltages. Voltages above 265 V AC are fuse protected but may cause permanent damage to the power supply. Voltages below 90 V AC may result in intermittent operation.
- Current draw values for one MM-10ACX with no satellite loudspeakers connected. AC Loop output not used.
- Current draw values for one MM-10ACX with two MM-4XP satellite loudspeakers connected. AC Loop output not used.



MM-10 — 04.199.004.02 A

Copyright © 2010  
Meyer Sound Laboratories Inc.  
All rights reserved

**MEYER SOUND LABORATORIES INC.**  
2832 San Pablo Avenue  
Berkeley, CA 94702

T: +1 510 486.1166  
F: +1 510 486.8356

techsupport@meyersound.com  
www.meyersound.com