



# **COSMO C1**

## **User Guide**

V1.1.0

For the latest and detailed user guide, please download it from the official website:  
[www.hollyland-tech.com/support/Download](http://www.hollyland-tech.com/support/Download)



**HOLLYVIEW**

Powered by Hollyland

## TYPICAL SETUP

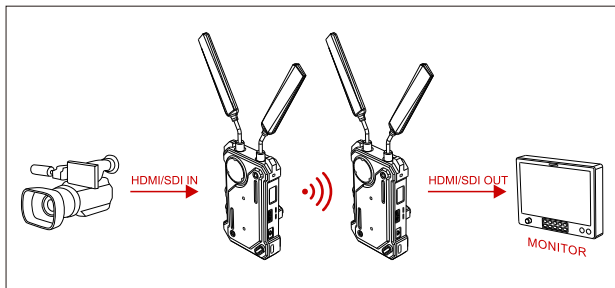

Note: The transmitter can be equipped with mushroom antenna. When there is a large height difference between the transmitter and receiver, it is recommended to use Hollyland mushroom antenna at the transmitter to improve the stability of wireless transmission.

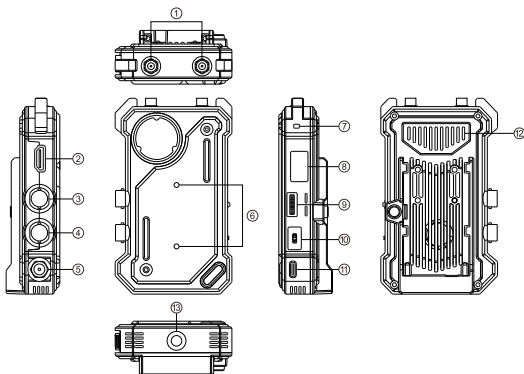

A

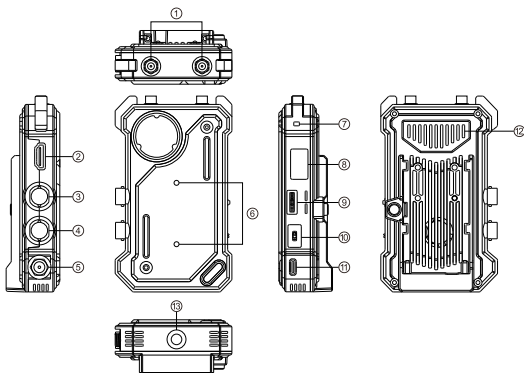

B

### A TRANSMITTER

- ① Antenna Interface
- ② HDMI Input
- ③ SDI Input
- ④ SDI Loop out
- ⑤ DC Power Input
- ⑥ Expansion Accessories Mounting Hole
- ⑦ LED Light (Yellow light indicates connection status, red light indicates low power)
- ⑧ OLED Screen
- ⑨ Thumbwheel Switch
- ⑩ Power Switch
- ⑪ USB Type-C Interface
- ⑫ Outlet
- ⑬ 1/4 Threaded hole

### B RECEIVER

- ① Antenna Interface
- ② HDMI Output
- ③ SDI Output1
- ④ SDI Output2
- ⑤ DC Power Input
- ⑥ Expansion Accessories Mounting Hole
- ⑦ LED Light (Yellow light indicates connection status, red light indicates low power)
- ⑧ OLED Screen
- ⑨ Thumbwheel Switch
- ⑩ Power Switch
- ⑪ USB Type-C Interface
- ⑫ Outlet
- ⑬ 1/4 Threaded Hole

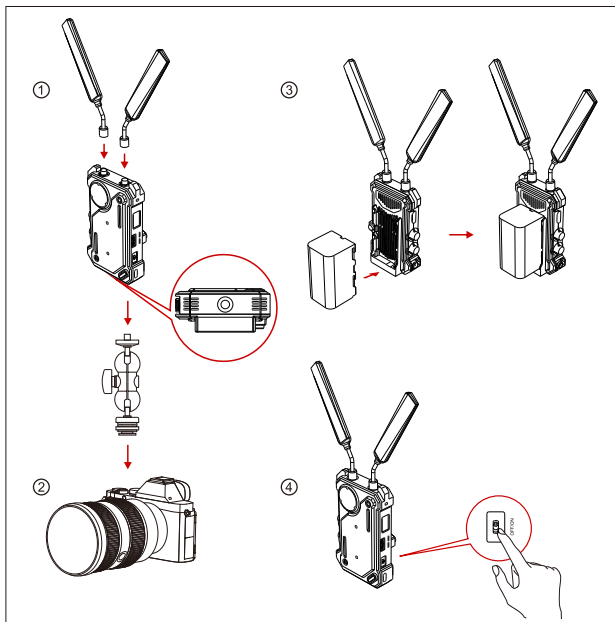

## ■ INSTALLATION OF TRANSMITTER

- ① Install the antenna according to the angle shown in the picture.
- ② Install the magic arm onto the 1/4 threaded hole of the transmitter and install the assembled transmitter into the camera body.
- ③ Install the battery (compatible with NP-F970 and others of same series).
- ④ Push the power switch to turn on the device.

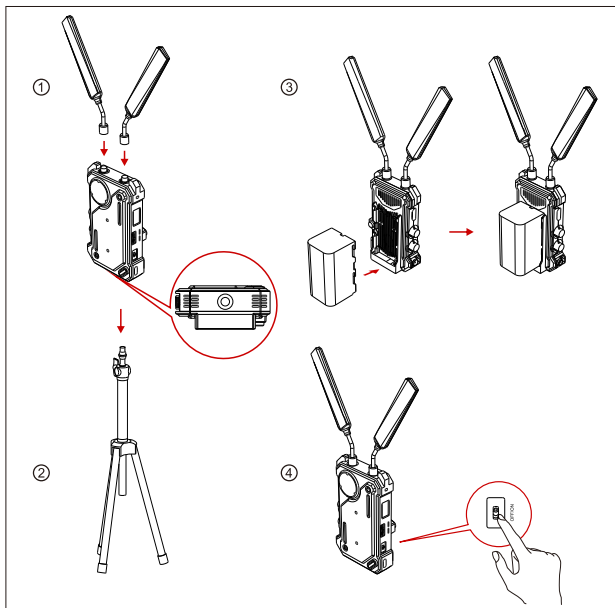

## INSTALLATION OF RECEIVER

- ① Install the antenna according to the angle shown in the picture.
- ② Install the receiver onto the stent through the 1/4 threaded hole on the bottom of the device.
- ③ Install the battery (compatible with NP-F970 and others of same series).
- ④ Push the power switch to turn on the device.



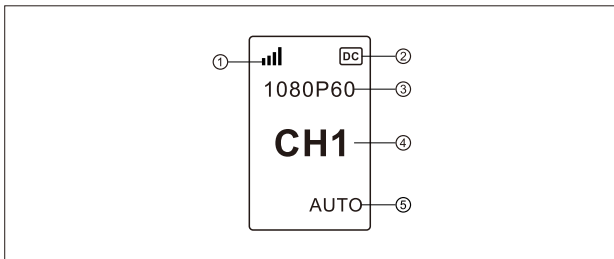

- ① Signal Strength
- ② Indicator of Power Supply
- ③ Video Format
- ④ Channel Display
- ⑤ Indicator of Auto-frequency-hopping

### NOTE

The "AUTO" indicates that the frequency point is in the automatic frequency hopping mode (the picture on the right); switch the frequency manually will change the device to the locked-frequency-mode state in the left picture.

### ENTER MENU

Long press the thumbwheel switch for three seconds to enter the menu. Flip the toggle wheel up or down to switch menu options, and click to confirm.

### CHANNEL SWITCHING

Toggle up/down the switcher to change the menu options on the transmitter or receiver, click the confirm key to confirm the channel, then the receiver and the transmitter channel will be synchronized automatically.

If encounter any problems in using the product or need any help, please follow these ways to get more technical support:

 Hollyland Products User Group

 HollylandTech

 HollylandTech

 support@hollyland-tech.com

 www.hollyland-tech.com

### FCC REQUIREMENT

Any changes or modifications not expressly approved by the party responsible for compliance could void the user's authority to operate the equipment.

This device complies with Part 15 of the FCC Rules. Operation is subject to the following two conditions:

- ① this device may not cause harmful interference, and
- ② this device must accept any interference received, including interference that may cause undesired operation.

Note: This equipment has been tested and found to comply with the limits for a Class B digital device, pursuant to Part 15 of the FCC Rules. These limits are designed to provide reasonable protection against harmful interference in a residential installation. This equipment generates, uses, and can radiate radio frequency energy, and if not installed and used in accordance with the instructions, may cause harmful interference to radio communications. However, there is no guarantee that interference will not occur in a particular installation. If this equipment does cause harmful interference to radio or television reception, which can be determined by turning the equipment off and on, the user is encouraged to try to correct the interference by one or more of the following measures:

- Reorient or relocate the receiving antenna.
- Increase the separation between the equipment and receiver.
- Connect the equipment into an outlet on a circuit different from that to which the receiver is connected.
- Consult the dealer or an experienced radio/TV technician for help.

This equipment complies with FCC radiation exposure limits set forth for an uncontrolled environment. This equipment should be installed and operated with a minimum distance of 20cm

between the radiator & your body. This transmitter must not be co-located or operating in conjunction with any other antenna or transmitter. t any interference received, including interference that may cause undesired operation.



 Hollyland Products User Group

 HollylandTech

 HollylandTech

 support@hollyland-tech.com

 www.hollyland-tech.com

**SHENZHEN HOLLYLAND TECHNOLOGY CO., LTD**

---

8F, 5D Building, Skyworth Innovation Valley, Tangtou, Shiyan, Baoan District Shenzhen, China.