



Faster Installation with pass-through RJ45 jacks. RPC-P Series remote power controls connect directly to each other—that's one pass around the install instead of back-and-forth to connect each unit to the sequencer.

Flexible. A step selection switch on each unit allows quick changes to the startup/shut-down sequence—without rewiring.

Scalable. Quickly add or remove devices using Cat5/6 cable and RJ45 connectors. The compatible sequencer (ordered separately) can control up to 80 devices from a single location.

DESCRIPTION:

Remote power controls are combined with sequencers and relays to provide an intrinsically safe, low voltage method of controlling AC power to equipment at remote locations. The RPC-P Series of remote power controls is designed for quick connections (with pass-through RJ45 jacks) and quick changes to the power sequencing order (via onboard DIP switch).

FEATURES:

- **Activation:** The first RPC-P Series remote power control in a system requires connection to a compatible sequencer (SEQ-P4 or SEQR-P4) for activation. Compatible remote power controls and relays can then be connected to the first unit in any order or combination (see page 2). *Note: The sequencer will require an external trigger (SPST switch or DSP voltage connection). Each device is sold separately.*
- **Scalable, Labor-Saving Installation:** RJ45 connectors and Cat5/Cat6 cable promote quick "pass-through" installation and make the system scalable—it's easy to add or remove units as system requirements change. And because the sequencing step is selected via the DIP switch on each unit, the startup/shutdown sequence can be quickly modified without a need to re-wire.
 - Install the RPC-P unit near the equipment to be controlled and connect it to a compatible sequencer (SEQ-P Series), remote power control (RPC-P Series), or relay (RY-P1 or RY-P2), keeping in mind that the first unit in the system requires connection to the sequencer.
 - Use the onboard DIP switch to select a step in the sequencing order (position 1-4). Multiple units can be assigned the same step.
 - Multiple RPC-P units can be connected to each other (or compatible relays) to control all from a single location. *Up to 20 RPC-P units per sequencing step.*
 - The maximum distance from the sequencer to the farthest RPC-P is 5,000 ft.

• Power:

- Power rating: 125VAC 15A
- Power input: 6 ft. attached cord with NEMA 5-15P plug.
- Power outlets: NEMA 5-15R duplex outlet

• **Chassis:** Steel chassis with mounting holes and black finish measures 7.5"L x 3.25"W x 1.75"H.

• **Third Party Approval:** ETL Listed to UL60065 (U.S. and Canada)

• **Origin:** Made in the U.S.A. with global components.

A&E SPECIFICATIONS:

The device for remotely controlling AC power shall be Lowell model RPC-P15, which shall be a 7.5" x 3.25" x 1.75" steel chassis with black powder epoxy finish. The remote power control shall feature a NEMA 5-15R duplex power outlet, RJ45 jacks (2), attached 6 ft. cord with NEMA 5-15P plug, test switch, LED status indicators, and an onboard DIP switch to select its position in the power sequencing order. Power rating shall 125VAC (15A). The unit shall be made in the U.S.A. with global components.

NOTE: The first RPC-P Series remote power control in a system is to be connected to an SEQ-P Series sequencer. Additional remote power controls (RPC-P Series) or relays (RY-P1 or RY-P2) can then be connected via RJ45 jacks. The sequencer will then activate/deactivate all connected devices.

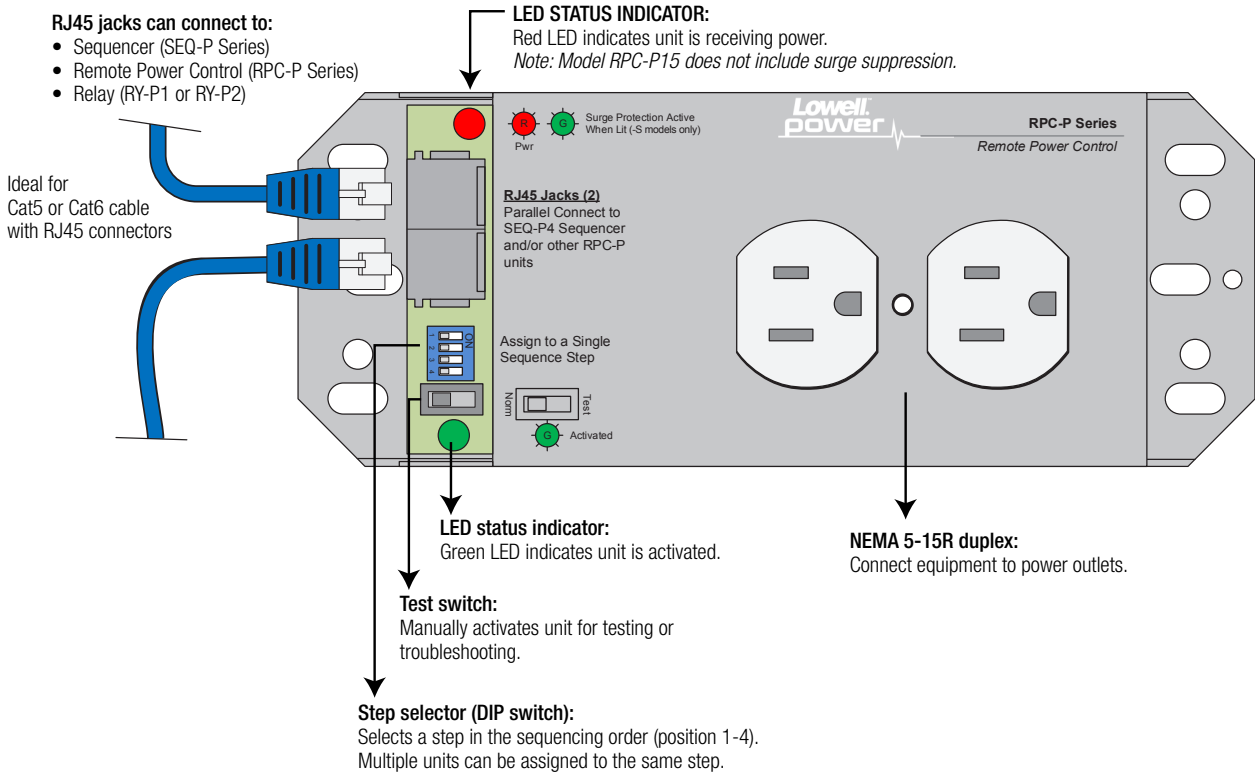

COMPATIBLE PASS-THROUGH DEVICES: Order separately.

All pass-through devices require sequencer SEQ-P4 or SEQR-P4 for activation. Optional add-on compatible devices are also listed in the chart below. See individual product spec sheets for more information.

Model No.	Description	Power Rating	Power Input Connection	Output Connection	Output Voltage Rating	Surge Supp.	Activation Trigger
SEQ-P4	Sequencer		Power supply				External switch or DSP conn*
SEQR-P4	Sequencer, rackmount		Power supply				Built-in sw, external sw or DSP*
RPC-P15	Remote Power Control	125VAC 15A	5-15P cord	5-15R duplex			SEQ-P4 or SEQR-P4**
RPC-P15-U	Remote Power Control	100-240VAC 15A	C14 cord	C13 duplex			SEQ-P4 or SEQR-P4**
RPC-P15-S	Remote Power Control	125VAC 15A	5-15P cord	5-15R duplex		✓	SEQ-P4 or SEQR-P4**
RPC-P20-SCD	Remote Power Control	125VAC 20A	5-20P cord	5-20R duplex		✓	SEQ-P4 or SEQR-P4**
RPC-P20-SHW	Remote Power Control	125VAC 20A	Flexible whip	5-20R duplex		✓	SEQ-P4 or SEQR-P4**
RPC-P30-SHW	Remote Power Control	125VAC 30A	Flexible whip	L5-30R twistlock		✓	SEQ-P4 or SEQR-P4**
RY-P1	Relay (1 DPDT)		Power supply		DPDT Relay 5A		SEQ-P4 or SEQR-P4**
RY-P2	Relay (2 DPDT)		Power supply		DPDT Relay 5A		SEQ-P4 or SEQR-P4**
ACS-2018-5C-RPCP-HW	Power Strip w/remote	120VAC 20A	Flexible whip	5-20R duplex (9)		✓	SEQ-P4 or SEQR-P4**

* Order activation trigger separately, as needed.

** Note that only the first remote device in a string requires connection to the sequencer for activation. A second device would connect to the first using the pass-through RJ45 jacks. Additional devices can be connected to each other in a similar way (up to 20 devices per step).

