



## DATASHEET

# A168 STAGE AUDIO INTERFACE

*Control, route and mix audio across  
multi-space venues.*

## KEY FEATURES

16 mic/line in and 8 line out expander I/O unit, providing portable remote I/O connectivity where it's required.

- 16 Mic Preamps on XLR with Phantom Power status LEDs
- 8 XLR Line Outs
- Proprietary CAT5 Connection via new DiGiCo A3232 protocol

## FRONT PANEL

16 x Mic Preamps on XLR with  
Phantom Power status LEDs

8 x XLR Line outs

## SIDE PANEL

2 x A3232 connections

1 x IEC C14

1 x Mains input (100-240VAC)

1 x Mode switch



4REA4 is a revolution in audio mixing for installed sound. Built on DiGiCo's world class reputation for the finest mixing consoles, 4REA4 helps you integrate your systems better than ever before.

The 4REA4 centralised DSP engine is the hub of the system containing powerful signal processing, expansion slots and connectivity to input/output modules, controllers and other consoles.

# A168 STAGE ROOM CONTROL



## A&E SPECIFICATION

The audio interface shall have sixteen mic/line inputs on XLR connectors with remote controlled pre-amplifiers. Inputs shall have individually selectable phantom power with front-panel indication of status. It shall also have eight line level outputs on XLR connectors.

There shall be two A3232 connections adjacent to a mode switch. The mode switch shall determine if the two connectors are to be used in Cascade mode or Redundant mode. In Cascade mode a cable may be run to a second audio interface for additional channel inputs. In Redundant mode a second cable may be run to a A3232 port on compatible hardware for increased infrastructure resilience.

The mains input shall accept 100 – 240V 50/60Hz 40W. The IEC input shall have an adjacent clip with which to secure the power input cable.

It shall be possible to mount the audio interface in a standard 19" rack using an optional rack-mount kit.

The dimensions of the audio interface shall be  
 421.4 (w) x 183 (h) x 194.3 (d) mm  
 16.59 (w) x 7.2 (h) x 7.64 (d) inches  
 Unpacked Weight: 7Kgs. (15.5lbs.)

The audio interface shall be a DiGiCo A168 STAGE



## SPECIFICATIONS

Mix/Line XLR Inputs: Balanced XLR, +48V Phantom Power

Mic/Line Preamp: Fully recallable

Analogue Gain: +5 to +60dB, 1dB steps

Pad: -20dB Active PAD

Maximum Input Level: +30dBu (PAD in)

Input Impedance: >4kΩ (Pad out), >10kΩ (Pad in)

Mic EIN: -127dB with 150Ω source

Analogue XLR Outputs: Balanced, Relay protected

Output Impedance: <75Ω

Nominal Output: +4dBu = 0dB meter reading

Maximum Output Level: +22dBu

Residual Output Noise: -93dBu (22Hz-22kHz)

Operating Temperature Range: 0°C to 35°C (32°F to 95°F)

Mains Voltage Operating Range: 100-240V AC, 50/60Hz

Mains Power Consumption: 35W max

Built on years of live audio experience and working closely with our customers, 4REA4 has been designed to meet the expanding performance requirements of large performance venues, conference centres, cruise ships, houses of worship, theatres, music venues and shared stages at festivals.

# LINE DRAWING

All dimensions in mm

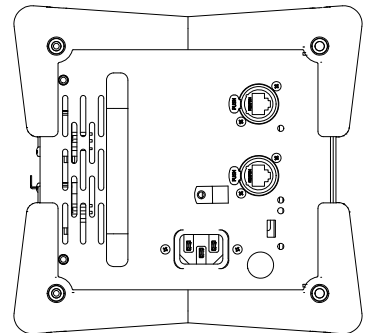
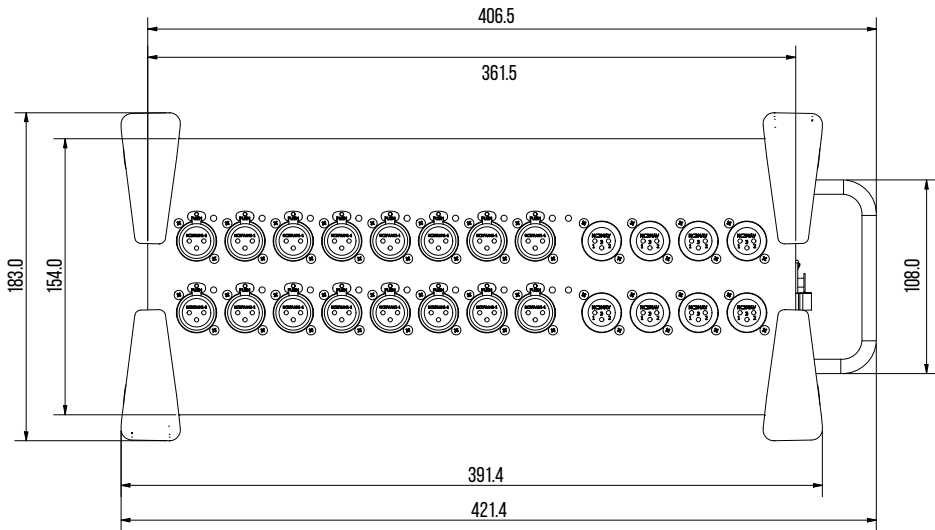
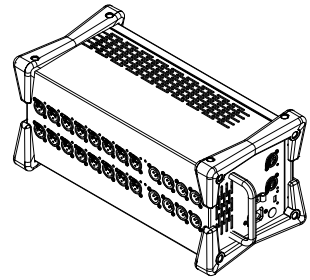
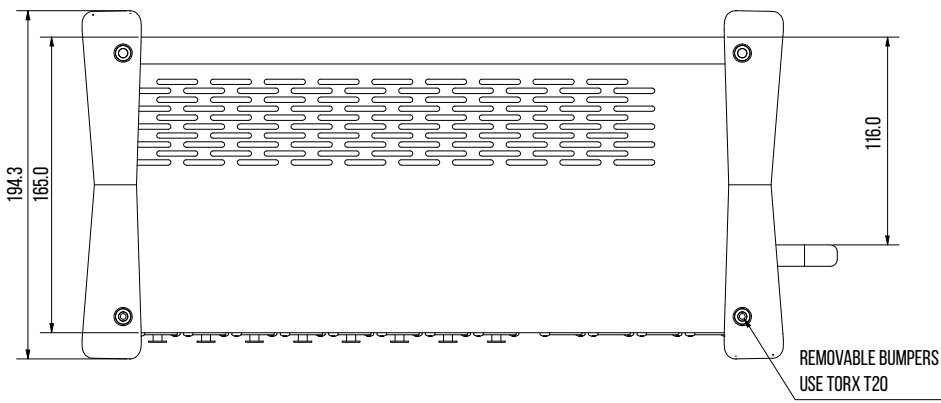

## DiGiCo HQ

Unit 10 Silverglade Business Park Leatherhead Road, Chessington,  
Surrey, KT9 2QL, United Kingdom  
info@digiconsoles.com

©DiGiCo 2019. All brand and product names are copyright to their respective owners

