

0301 - BAFFLE, ROUND

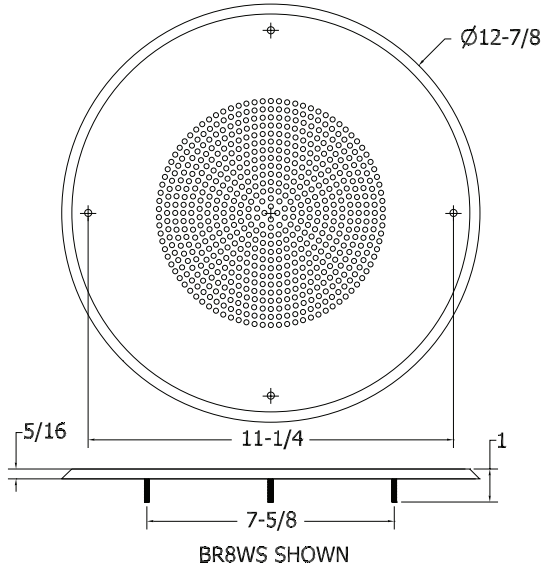

BR8WS SHOWN

GENERAL DESCRIPTION

The Quam BR8WS is a 22 gage steel, round speaker baffle with 4 welded 8-32 x 1" studs on the back surface. Finish: White baked epoxy hybrid.

The Quam BR8W is a 22 gauge steel, round speaker baffle with 4 supplied "white-head" 8-32 x 1" Phillips truss head mounting screws through the baffle. Finish: White baked epoxy hybrid.

INTENDED USE

Indoor environment. For use with 8" frame loudspeakers and related components.

SYSTEM COMPONENTS

N/A

RECOMMENDED ADDITIONAL QUAM COMPONENTS

- 0104.4 - Speaker, Transformer
- 0201 - Coaxial Loudspeakers, Individual
- 0202 - Dual Voice Coil Loudspeakers, Individual
- 0203 - Public Address Loudspeakers, Individual
(Except 4C3PAB, 4C10PAB, 12C10PAXB)
- 0401 - Flush Mounted Back Boxes
- 0402 - Loudspeaker Mounting Devices
(Except SSB-4, SSB-6, SSB-9)

Recommended construction sequences, installation instructions and A&E Specifications are available in various formats on the Quam Architects' and Engineers' Resources CD or on the web at www.quamspeakers.com

Quam-Nichols Company

234 East Marquette Road, Chicago, IL 60637
 Phone (800) NEED NOW Fax (888) NEED NOW
 (800) 633-3669 (888) 633-3669
 E-Mail: neednow@qnc.com www.quamspeakers.com

