

G62



User guide

Copyright ©

All rights reserved. No part of this document may be copied, reproduced or translated. It shall not otherwise be recorded, transmitted or stored in a retrieval system without the prior written consent of Barco.

Changes

Barco provides this manual 'as is' without warranty of any kind, either expressed or implied, including but not limited to the implied warranties or merchantability and fitness for a particular purpose. Barco may make improvements and/or changes to the product(s) and/or the program(s) described in this publication at any time without notice.

This publication could contain technical inaccuracies or typographical errors. Changes are periodically made to the information in this publication; these changes are incorporated in new editions of this publication.

The latest edition of Barco manuals can be downloaded from the Barco web site www.barco.com or from the secured Barco web site <https://www.barco.com/en/signin>.

Trademarks

Brand and product names mentioned in this manual may be trademarks, registered trademarks or copyrights of their respective holders. All brand and product names mentioned in this manual serve as comments or examples and are not to be understood as advertising for the products or their manufacturers.

Guarantee and Compensation

Barco provides a guarantee relating to perfect manufacturing as part of the legally stipulated terms of guarantee. On receipt, the purchaser must immediately inspect all delivered goods for damage incurred during transport, as well as for material and manufacturing faults Barco must be informed immediately in writing of any complaints.

The period of guarantee begins on the date of transfer of risks, in the case of special systems and software on the date of commissioning, at latest 30 days after the transfer of risks. In the event of justified notice of complaint, Barco can repair the fault or provide a replacement at its own discretion within an appropriate period. If this measure proves to be impossible or unsuccessful, the purchaser can demand a reduction in the purchase price or cancellation of the contract. All other claims, in particular those relating to compensation for direct or indirect damage, and also damage attributed to the operation of software as well as to other services provided by Barco, being a component of the system or independent service, will be deemed invalid provided the damage is not proven to be attributed to the absence of properties guaranteed in writing or due to the intent or gross negligence or part of Barco.

If the purchaser or a third party carries out modifications or repairs on goods delivered by Barco, or if the goods are handled incorrectly, in particular if the systems are operated incorrectly or if, after the transfer of risks, the goods are subject to influences not agreed upon in the contract, all guarantee claims of the purchaser will be rendered invalid. Not included in the guarantee coverage are system failures which are attributed to programs or special electronic circuitry provided by the purchaser, e.g. interfaces. Normal wear as well as normal maintenance are not subject to the guarantee provided by Barco either.

The environmental conditions as well as the servicing and maintenance regulations specified in this manual must be complied with by the customer.

Patent protection

Please refer to www.barco.com/about-barco/legal/patents.

Table of contents

1	Safety	9
1.1	General considerations	10
1.2	Important safety instructions	12
1.3	Product Safety Labels	15
1.4	Risk Group 3 Safety	16
1.4.1	General considerations	16
1.4.2	High Brightness precautions: Hazard Distance	17
1.4.3	HD for fully enclosed projection systems	19
1.5	Regulatory	20
2	Product overview	21
2.1	Main unit	22
3	Input & Communication	25
3.1	Input/Output (I/O) Panel	26
3.2	Control panel	26
4	Remote Control Unit (RCU)	29
4.1	RCU battery installation	30
4.2	Overview of the RCU	31
4.3	Projector Address (ID)	31
4.4	Using the RCU	32
5	Powering On/Off the projector	35
5.1	Powering On the projector	36
5.2	Powering Off the Projector	36
6	User controls	39
6.1	On-Screen Display Menus	40
7	User controls — Installation	41
7.1	Lens	43
7.2	Orientation	43
7.3	Aspect Ratio	44
7.4	Scale	44
7.5	Signal	44
7.6	Edge Mask	46

7.7	Geometry Correction.....	46
7.8	Multi-Projection	48
7.9	Test Pattern	49
7.10	Freeze Screen	50
7.11	Reset.....	50
8	User control — Image menu	51
8.1	Color Mode	52
8.2	Brightness	52
8.3	Contrast.....	52
8.4	Saturation	52
8.5	Tint.....	52
8.6	Sharpness.....	52
8.7	Gamma.....	53
8.8	White Balance.....	53
8.9	Advanced Color	53
8.10	Advanced Image	55
8.11	Save to User	57
8.12	Apply to User.....	57
8.13	Reset.....	57
9	User controls — Communication menu	59
9.1	Projector ID.....	60
9.2	Remote Setup	60
9.3	Network Setup	60
9.4	Control.....	61
9.5	Using the web control center.....	62
9.6	Using RS232 command by Telnet	63
9.7	Baud Rate	63
9.8	Reset.....	64
10	System menu.....	65
10.1	Language.....	66
10.2	Date and Time	66
10.3	On Screen Display	67
10.4	Logo Setup	67
10.5	Schedule.....	67
10.6	Standby Mode.....	70
10.7	Power Settings	70
10.8	Light Source Settings.....	70
10.9	Shutter.....	70
10.10	Security.....	71
10.11	Backlight	71
10.12	High Altitude.....	71
10.13	12V Trigger	72
10.14	User Data	72
10.15	Reset.....	72
10.16	Service	72
11	Information menu.....	73
11.1	Projector information and status.....	74
12	Troubleshooting	75
12.1	Projector Problems	76

12.2	LED indication chart	77
A	Specifications	79
A.1	Specifications for G62-W9	80
A.2	Specifications for G62-W11	81
A.3	Specifications for G62-W14	83
A.4	Dimensions of the G62	84
A.5	Ceiling mount	85
A.6	Compatibility modes	86
A.7	EDID table	90
B	Regulatory information	93
B.1	Product compliance	94
B.2	China RoHS compliance	95
B.3	Taiwan RoHS compliance	96
B.4	Turkey RoHS compliance	97
B.5	Disposal information	97
B.6	Contact information	98
B.7	Download Product Manual	98
	Index	99

Safety

1

1.1	General considerations	10
1.2	Important safety instructions	12
1.3	Product Safety Labels	15
1.4	Risk Group 3 Safety	16
1.5	Regulatory	20

About this document

Read this document attentively. It contains important information to prevent personal injury while installing and using the G62 projector. Furthermore, it includes several cautions to prevent damage to the G62 projector. Ensure that you understand and follow all safety guidelines, safety instructions and warnings mentioned in this chapter before installing the G62 projector.

Clarification of the term “G62 ” used in this document

When referring in this document to the term “G62 ” means that the content is applicable for following Barco products:

- G62-W9, G62-W11, G62-W14

Model certification name

- G62



Barco provides a guarantee relating to perfect manufacturing as part of the legally stipulated terms of guarantee. Observing the specification mentioned in this chapter is critical for projector performance. Neglecting this can result in loss of warranty.

1.1 General considerations

General safety instructions

- Before operating this equipment please read this manual thoroughly and retain it for future reference.
- Installation and preliminary adjustments should be performed by qualified Barco personnel or by authorized Barco service dealers.
- All warnings on the projector and in the documentation manuals should be adhered to.
- All instructions for operating and use of this equipment must be followed precisely.
- All local installation codes should be adhered to.
- IEC 60825-1: 2014 Class 1 RG2
- IEC 62471-5:2015 RG2
- Additional instructions to supervise children, no staring, and not use optical aids.
- Additional instructions to install above the reach of children.
- Notice is given to supervise children and to never allow them to stare into the projector beam at any distance from the projector.
- Notice is given to use caution when using the remote control for starting the projector while in front of the projection lens.
- Notice is given to the user to avoid the use of optical aids such as binoculars or telescopes inside the beam.
- “As with any bright light source, do not stare into the beam, RG2 IEC 62471-5:2015”.
- “WARNING: MOUNT ABOVE THE HEADS OF CHILDREN. The use of a ceiling mount is recommended with this product to place it above the eyes of children.

Notice on safety

This equipment is built in accordance with the requirements of the applicable international safety standards. These safety standards impose important requirements on the use of safety critical components, materials and insulation, in order to protect the user or operator against risk of electric shock and energy hazard and having access to live parts. Safety standards also impose limits to the internal and external temperature rises, radiation levels, mechanical stability and strength, enclosure construction and protection against the risk of fire. Simulated single fault condition testing ensures the safety of the equipment to the user even when the equipment's normal operation fails.

Laser safety precautions

This product is classified as Class 1 Laser Product-Risk Group 2 of IEC 60825-1:2014 and also complies with 21 CFR 1040.10 and 1040.11 as a Risk Group 2, LIP (Laser Illuminated Projector) as defined in IEC 62471-5: Ed.1.0. For more information see Laser Notice No. 57, dated May 8, 2019.

To ensure safety operation, read all laser safety precautions before installing and operating the projector.

According to IEC 60825-1:2014 and IEC 62471:2006, this projector may become CLASS 1 LASER PRODUCT - RISK GROUP 3 product when installed with G-lens (throw ratio 2.90-5.50).

To ensure safety operation, read all laser safety precautions before installing or operating the projector.

For G62-W9

As with any bright source, do not stare into the direct beam, RG2 IEC 62471-5:2015 This projector is class 1 laser product of IEC/EN 60825-1:2014 and risk group 2 with the requirements of IEC 62471-5:2015 Additional instructions to supervise children, no staring, and not use optical aids.

Notice is given to supervise children and to never allow them to stare into the projector beam at any distance from the projector.

Notice is given to use caution when using the remote control for starting the projector while in front of the projection lens.

Notice is given to the user to avoid the use of optical aids such as binoculars or telescopes inside the beam.

For G62-W11 & G62-W14

As with any bright source, do not stare into the direct beam, RG2 IEC 62471-5:2015 No direct exposure to the beam shall be permitted, RG3 IEC 62471-5:2015 (When Throw Ratio large than 2.9).

This projector is class 1 laser product of IEC/EN 60825-1:2014 and risk group 2 with the requirements of IEC 62471-5:2015.

Operators shall control access to the beam within the hazard distance or install the product at the height that will prevent exposures of spectators' eyes within the hazard distance (When Throw Ratio large than 2.9).

Additional instructions to supervise children, no staring, and not use optical aids.

Notice is given to supervise children and to never allow them to stare into the projector beam at any distance from the projector.

Notice is given to use caution when using the remote control for starting the projector while in front of the projection lens.

Notice is given to the user to avoid the use of optical aids such as binoculars or telescopes inside the beam.

Light Intensity Hazard Distance

This projector may become Class 1 Laser Product-Risk Group 3 (RG3) when installed with G LENS (2.90 - 5.50 : 1) lens (throw ratio 2.90-5.50). Permanent eye injury is possible when exposed to the high intensity light beam within the hazard distance (HD).

For G62-W11

Projection Lens	Throw Ratio	Classification and Requirements for Laser Illuminated Projectors (LIPs)		
G LENS (2.90 - 5.50 : 1)	2.90-5.50	IEC 60825-1:2014	IEC 62471-5:2015	
		CLASS 1	RISK GROUP 3	Hazard distance: 2.30 m

For G62-W14

Projection Lens	Throw Ratio	Classification and Requirements for Laser Illuminated Projectors (LIPs)		
G LENS (2.90 - 5.50 : 1)	2.90-5.50	IEC 60825-1:2014	IEC 62471-5:2015	
		CLASS 1	RISK GROUP 3	Hazard distance: 2.55 m

Follow the precautions to avoid light intensity hazard.

- NEVER look into the lens! High intensity light beam.
- Permanent eye injury is possible when exposed to the high intensity light beam within the hazard distance.
- Operators shall control access to the light beam within the hazard distance or install the product at a height that will prevent eye exposure within the hazard distance.
- Do not place any reflective objects in the light path of the projector.

User definition

Throughout this manual, the term SERVICE PERSONNEL refers to Barco authorized persons having appropriate technical training and experience necessary to be knowledgeable of potential hazards to which they are exposed (including, but not limited to HIGH VOLTAGE ELECTRIC and ELECTRONIC CIRCUITRY and HIGH BRIGHTNESS PROJECTORS) in performing a task, and of measures to minimize the potential risk to themselves or other persons. Only Barco authorized SERVICE PERSONNEL, knowledgeable of such risks, are allowed to perform service functions inside the product enclosure. The term USER and OPERATOR refers to any person other than SERVICE PERSONNEL. When installing an interchangeable lens with a throw ratio that make the projector become RG3, refer to chapter "Risk Group 3 Safety", page 9. Such combination of projector and lens are intended for professional use only, and are not intended for consumer use.

FOR PROFESSIONAL USE ONLY means installation can only be carried out by Barco AUTHORIZED PERSONNEL familiar with potential hazards associated with high intensity light beams.

1.2 Important safety instructions

To prevent the risk of electrical shock

- This product should be operated from a mono phase AC power source.
- This apparatus must be grounded (earthed) via the supplied 3 conductor AC power cable. If none of the supplied power cables are the correct one, consult your dealer. If you are unable to insert the plug into the outlet, contact your electrician to replace your obsolete outlet. Do not defeat the purpose of the grounding-type plug.
- Do not allow anything to rest on the power cord. Do not locate this product where persons will walk on the cord. To disconnect the cord, pull it out by the plug. Never pull the cord itself.
- Use only the power cord supplied with your device. While appearing to be similar, other power cords have not been safety tested at the factory and may not be used to power the device. For a replacement power cord, contact your dealer.
- Do not operate the projector with a damaged cord. Replace the cord.
- Do not operate the projector if the projector has been dropped or damaged until it has been examined and approved for operation by a qualified service technician. Position the cord so that it will not be tripped over, pulled, or contact hot surfaces.
- If an extension cord is necessary, a cord with a current rating at least equal to that of the projector should be used. A cord rated for less amperage than the projector may overheat.
- Never push objects of any kind into this product through cabinet slots as they may touch dangerous voltage points or short out parts that could result in a risk of fire or electrical shock.
- Do not expose this projector to rain or moisture.
- Do not immerse or expose this projector in water or other liquids.
- Do not spill liquid of any kind on this projector.
- Should any liquid or solid object fall into the cabinet, unplug the set and have it checked by qualified service personnel before resuming operations.
- Do not disassemble this projector, always take it to an authorized trained service person when service or repair work is required.
- Do not use an accessory attachment which is not recommended by the manufacturer.
- Lightning - For added protection for this video product during a lightning storm, or when it is left unattended and unused for long periods of time, unplug it from the wall outlet. This will prevent damage to the device due to lightning and AC power-line surges.

To prevent personal injury

- To prevent injury and physical damage, always read this manual and all labels on the system before connecting to the wall outlet or adjusting the projector.
- To prevent injury, take note of the weight of the projector.
- To prevent injury, ensure that the lens and all covers are correctly installed. See installation procedures.
- Warning: high intensity light beam. NEVER look into the lens ! High luminance could result in damage to the eye.
- Warning: extremely high brightness laser: This projector uses extremely high brightness laser. Never attempt to look directly into the lens or at the laser.
- Before attempting to remove any of the projector's covers, you must turn off the projector and disconnect from the wall outlet.
- When required to switch off the projector, to access parts inside, always disconnect the power cord from the power net.
- The power input at the projector side is considered as the disconnect device. When required to switch off the projector, to access parts inside, always disconnect the power cord at the projector side. In case the power input at the projector side is not accessible (e.g. ceiling mount), the socket outlet supplying the projector shall be installed nearby the projector and be easily accessible, or a readily accessible general disconnect device shall be incorporated in the fixed wiring.
- Do not place this equipment on an unstable cart, stand, or table. The product may fall, causing serious damage to it and possible injury to the user.
- It is hazardous to operate without lens or shield. Lenses, shields or ultra violet screens shall be changed if they have become visibly damaged to such an extent that their effectiveness is impaired. For example by cracks or deep scratches.
- Exposure to UV radiation: Some medications are known to make individuals extra sensitive to UV radiation. The American Conference of Governmental Industrial Hygienists (ACGIH) recommends

occupational UV exposure for an 8-hour day to be less than 0,1 micro-watts per square centimeters of effective UV radiation. An evaluation of the workplace is advised to assure employees are not exposed to cumulative radiation levels exceeding these government guidelines. The exposure of this UV radiation is allowed for only 1 hour per day for maintenance and service persons.

To prevent fire hazard

- Do not place flammable or combustible materials near the projector!
- Barco large screen projection products are designed and manufactured to meet the most stringent safety regulations. This projector radiates heat on its external surfaces and from ventilation ducts during normal operation, which is both normal and safe. Exposing flammable or combustible materials into close proximity of this projector could result in the spontaneous ignition of that material, resulting in a fire. For this reason, it is absolutely necessary to leave an "exclusion zone" around all external surfaces of the projector whereby no flammable or combustible materials are present. The exclusion zone must be not less than 100 cm (39.4") for all DLP projectors. The exclusion zone on the lens side must be at least 5 m. Do not cover the projector or the lens with any material while the projector is in operation. Keep flammable and combustible materials away from the projector at all times. Mount the projector in a well-ventilated area away from sources of ignition and out of direct sun light. Never expose the projector to rain or moisture. In the event of fire, use sand, CO2 or dry powder fire extinguishers. Never use water on an electrical fire. Always have service performed on this projector by authorized Barco service personnel. Always insist on genuine Barco replacement parts. Never use non-Barco replacement parts as they may degrade the safety of this projector.
- Slots and openings in this equipment are provided for ventilation. To ensure reliable operation of the projector and to protect it from overheating, these openings must not be blocked or covered. The openings should never be blocked by placing the projector too close to walls, or other similar surface. This projector should never be placed near or over a radiator or heat register. This projector should not be placed in a built-in installation or enclosure unless proper ventilation is provided.
- Projection rooms must be well ventilated or cooled in order to avoid build up of heat.
- Let the projector cool down completely before storing. Remove cord from the projector when storing.

To prevent projector damage

- Always remove lens cap before switching on the projector. If the lens cap is not removed, it may melt due to the high energy light emitted through the lens. Melting the lens cap may permanently damage the surface of the projection lens.
- Cleaning the booth area would be monthly minimum. Neglecting this could result in disrupting the air flow inside the projector, causing overheating. Overheating may lead to the projector shutting down during operation.
- The projector must always be installed in a manner which ensures free flow of air into its air inlets and unimpeded evacuation of the hot air from its cooling system.
- If more than one projector is installed in a common projection booth, the exhaust air flow requirements are valid for EACH individual projector system. Note that inadequate air extraction or cooling will result in decreased life expectancy of the projector as a whole as well as causing premature failure of the lasers.
- In order to ensure that correct airflow is maintained, and that the projector complies with Electromagnetic Compatibility (EMC) requirements, it should always be operated with all of its covers in place.
- Slots and openings in the cabinet are provided for ventilation. To ensure reliable operation of the product and to protect it from overheating, these openings must not be blocked or covered. The openings should never be blocked by placing the product on a bed, sofa, rug, or other similar surface. This product should never be placed near or over a radiator or heat register. The device should not be placed in a built-in installation or enclosure unless proper ventilation is provided.
- Ensure that nothing can be spilled on, or dropped inside the projector. If this does happen, switch off and unplug the mains supply immediately. Do not operate the projector again until it has been checked by qualified service personnel.
- Do not block the projector cooling fans or free air movement around the projector.
- Do not use this equipment near water.
- Special care for Laser Beams: Special care should be used when DLP projectors are used in the same room as high power laser equipment. Direct or indirect hitting of a laser beam on to the lens can severely damage the Digital Mirror Devices™ in which case there is a loss of warranty.
- Never place the projector in direct sun light. Sun light on the lens can severely damage the Digital Mirror Devices™ in which case there is a loss of warranty.
- Save the original shipping carton and packing material. They will come in handy if you ever have to ship your equipment. For maximum protection, repack your set as it was originally packed at the factory.

- Unplug this product from the wall outlet before cleaning. Do not use liquid cleaners or aerosol cleaners. Use a damp cloth for cleaning. Never use strong solvents, such as thinner or benzene, or abrasive cleaners, since these will damage the cabinet. Stubborn stains may be removed with a cloth lightly dampened with mild detergent solution.
- To ensure the highest optical performance and resolution, the projection lenses are specially treated with an anti-reflective coating, therefore, avoid touching the lens. To remove dust on the lens, use a soft dry cloth. Do not use a damp cloth, detergent solution, or thinner.
- Rated operating ambient temperature: $t_a = 5\text{ }^{\circ}\text{C}$ (41 $^{\circ}\text{F}$) to 40 $^{\circ}\text{C}$ (104 $^{\circ}\text{F}$).
- Rated operating humidity: 10% RH to 85% RH (non-condensing). This projector can be set to any angle within 360° range.
- Allowing proper space around the projector is critical for proper air circulation and cooling of the unit. The dimensions shown here indicate the minimum space required.

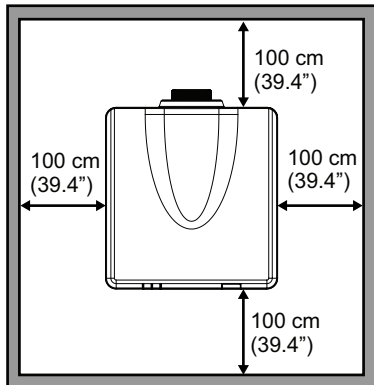
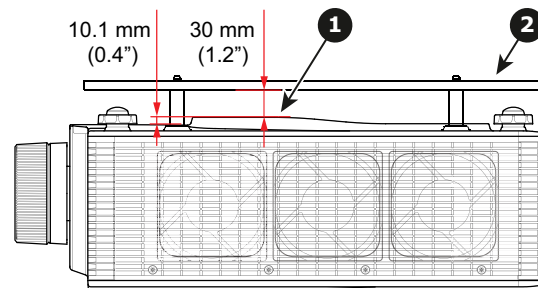

Image 1-1

- 1 Bottom intake vents.
- 2 Ceiling mount plate.



- For ceiling mounted installations, make sure to leave 30 mm (1.2") between the ceiling mount and the bottom intake vents of the projector.

To prevent battery explosion

- Danger of explosion if battery is incorrectly installed.
- Replace only with the same or equivalent type recommended by the manufacturer.
- For disposal of used batteries, always consult federal, state, local and provincial hazardous waste disposal rules and regulations to ensure proper disposal.

On servicing

- Do not attempt to service this product yourself, as opening or removing covers may expose you to dangerous voltage potentials and risk of electric shock.
- Refer all servicing to qualified service personnel.
- Attempts to alter the factory-set internal controls or to change other control settings not specially discussed in this manual can lead to permanent damage to the projector and cancellation of the warranty.
- Replacement parts: When replacement parts are required, be sure the service technician has used original Barco replacement parts or authorized replacement parts which have the same characteristics as the Barco original part. Unauthorized substitutions may result in degraded performance and reliability, fire, electric shock or other hazards. Unauthorized substitutions may void warranty.
- Safety check: Upon completion of any service or repairs to this projector, ask the service technician to perform safety checks to determine that the product is in proper operating condition.

Malfunction unit

Remove all power from the projector and refer servicing to qualified service technicians under the following conditions:

- When the power cord or plug is damaged or frayed.
- If liquid has been spilled into the equipment.
- If the product has been exposed to rain or water.

- If the product does not operate normally when the operating instructions are followed. Adjust only those controls that are covered by the operating instructions since improper adjustment of the other controls may result in damage and will often require extensive work by a qualified technician to restore the product to normal operation.
- If the product has been dropped or the cabinet has been damaged.
- If the product exhibits a distinct change in performance, indicating a need for service.



Safety Data Sheets for Hazardous Chemicals

For safe handling information on chemical products, consult the Safety Data Sheet (SDS). SDSs are available upon request via safetydatasheets@barco.com.

1.3 Product Safety Labels

Light beam related safety labels

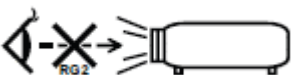
For G62-W9

Label image	Label description
	<p>Risk Group 2, IEC60825-1:2014. Do not look into the laser light. The extremely high brightness may cause permanent eye damage.</p>
	<p>IEC 60825-1:2014 CLASS 1 LASER PRODUCT RISK GROUP 2 Complies with 21 CFR 1040.10 and 1040.11 except for conformance as a Risk Group 2 LIP as defined in IEC 62471-5:Ed.1.0. For more information see Laser Notice No. 57, dated May 8, 2019.</p>
	<p>Warning: mount above the heads of children Additional warning against eye exposure for close exposures less than 1 m.</p>

For G62-W11 & G62-W14

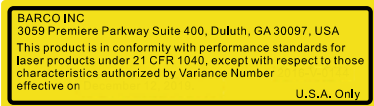
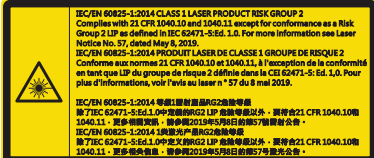
Label image	Label description
	<p>FDA laser variance (US projectors only). This product is in conformity with performance standards for laser products under 21 CFR 1040, except with respect to those characteristics authorized by Variance Number xxxx-x-xxxx effective on [effective date of variance approval]. For the exact Variance Number and effective date see yellow label on the projector.</p>
	<p>IEC 60825-1:2014 CLASS 1 LASER PRODUCT RISK GROUP 2 Complies with 21 CFR 1040.10 and 1040.11 except for conformance as a Risk Group 2 LIP as defined in IEC 62471-5:Ed.1.0. For more information see Laser Notice No. 57, dated May 8, 2019.</p>

Label image

Label description



Warning: mount above the heads of children

Additional warning against eye exposure for close exposures less than 1 m.



This projector may become RG3 when an interchangeable lens with throw ratio greater than 2.90 is installed. Refer to the manual for the lens list and hazard distance before operation. Such combinations of projector and lens are intended for professional use only, and are not intended for consumer use. "Not for household use". "No direct exposure to beam shall be permitted, which can cause injury to the retina in the back of the eye."

Laser Aperture

Do not look into the Lens.

Ouverture Rayonnement Laser

Ne regarde pas dans la lentille

1.4 Risk Group 3 Safety

1.4.1 General considerations

Notice on optical radiation from G62 Projector when it becomes Risk Group 3.

- For RG3, no direct exposure to the beam shall be permitted. For RG3, operators shall control access to the beam within the hazard distance or install the product at a height that will prevent eye exposure within the hazard distance.
- This projector has one or several built-in Class 4 laser clusters. Disassembly or modification is very dangerous and should never be attempted.
- Any operation or adjustment not specifically instructed by the user's guide creates the risk of hazardous laser radiation exposure.
- Do not open or disassemble the projector as this may cause damage by the exposure of laser radiation.

FOR PROFESSIONAL USE ONLY means installation can only be carried out by Barco AUTHORIZED PERSONNEL familiar with potential hazards associated with high intensity light beams.



WARNING: No direct exposure to the beam within the hazard distance shall be permitted, RG3 (Risk Group 3) IEC EN 62471-5:2015



CAUTION: Use of controls or adjustments or performance of procedures other than those specified herein may result in hazardous radiation exposure.

PPE (Personal Protective Equipment) description.

A skilled person or service person shall be worn protective clothes and goggles when access to restricted area.

Possible skin or eye damage.

Disconnect power before servicing.

1.4.2 High Brightness precautions: Hazard Distance



HD

Hazard Distance (HD) is the distance measured from the projection lens at which the intensity or the energy per surface unit becomes lower than the applicable exposure limit on the cornea or on the skin. The light beam is considered (to be) unsafe for exposure if the distance from a person to the light source is less than the HD.

Restriction Zone (RZ) based on the HD

The HD depends on the amount of lumens produced by the projector and the type of lens installed. See chapter “General considerations”, page 16.

To protect untrained end users (as cinema visitors, spectators) the installation shall comply with the following installation requirements: Operators shall control access to the beam within the hazard distance or install the product at a height that will prevent spectators' eyes from being in the hazard distance. Radiation levels in excess of the limits will not be permitted at any point less than 2.0 meter (SH) above any surface upon which persons other than operators, performers, or employees are permitted to stand or less than 1.0 meter (SW) lateral separation from any place where such persons are permitted to be. In environments where unrestrained behavior is reasonably foreseeable, the minimum separation height should be greater than or equal to 3.0 meter to prevent potential exposure, for example by an individual sitting on another individual's shoulders, within the HD.

These values are minimum values and are based on the guidance provided in IEC 62471-5:2015 section 6.6.3.5.

The installer and user must understand the risk and apply protective measures based upon the hazard distance as indicated on the label and in the user information. Installation method, separation height, barriers, detection system or other applicable control measure shall prevent hazardous eye access to the radiation within the hazard distance.

For example, projectors that have a HD greater than 1 m and emit light into an uncontrolled area where persons may be present should be positioned in accordance with “the fixed projector installation” parameters, resulting in a HD that does not extend into the audience area unless the beam is at least 2.0 meter above the floor level. In environments where unrestrained behavior is reasonably foreseeable, the minimum separation height should be greater than or equal to 3.0 meter to prevent potential exposure, for example by an individual sitting on another individual's shoulders, within the HD. Sufficiently large separation height may be achieved by mounting the image projector on the ceiling or through the use of physical barriers.

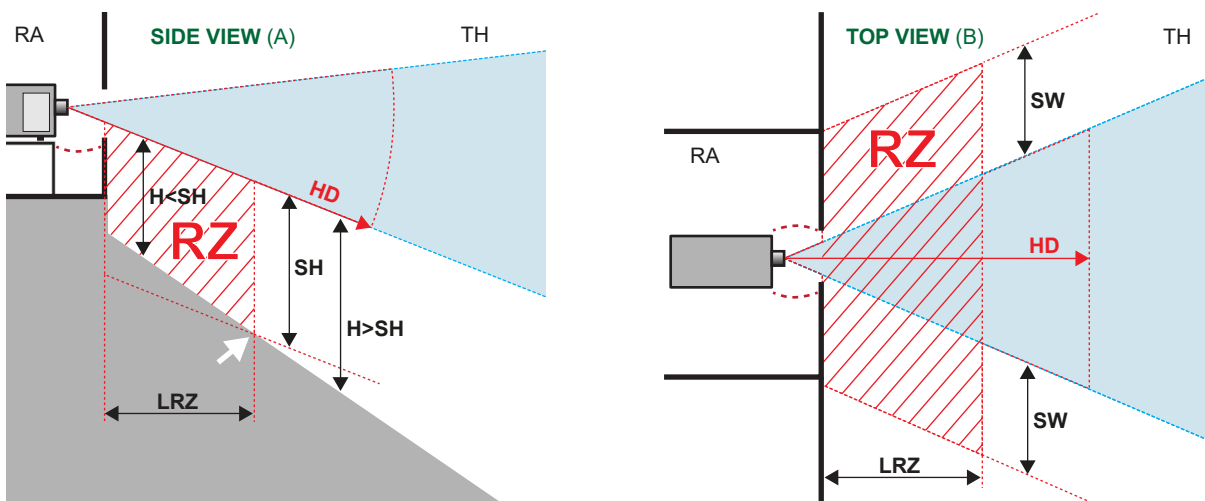

Image 1–2

- A** Side view
- B** Top view
- RA** Restricted Access location (boot area of projector).
- TH** Theater
- RZ** Restriction Zone in the theater

- HD** Hazard Distance
- LRZ** Length Restriction Zone in the theater
- H** Height between surface floor and the light beam
- SH** Separation Height
- SW** Separation Width

Based on national requirements, no person is allowed to enter the projected beam within the zone between the projection lens and the related hazard distance (HD). This shall be physically impossible by creating

sufficient separation height or by placing barriers. The minimum separation height takes into account the surface upon which persons other than operator, performers or employees are permitted to stand.

On [Image 1–3](#) a typical setup is displayed. It must be verified if these minimum requirements are met. If required a restricted zone (RZ) in the theater must be established. This can be done by using physical barrier, like a red rope as illustrated in [Image 1–3](#).

The restricted area sticker can be replaced by a sticker with only the symbol.

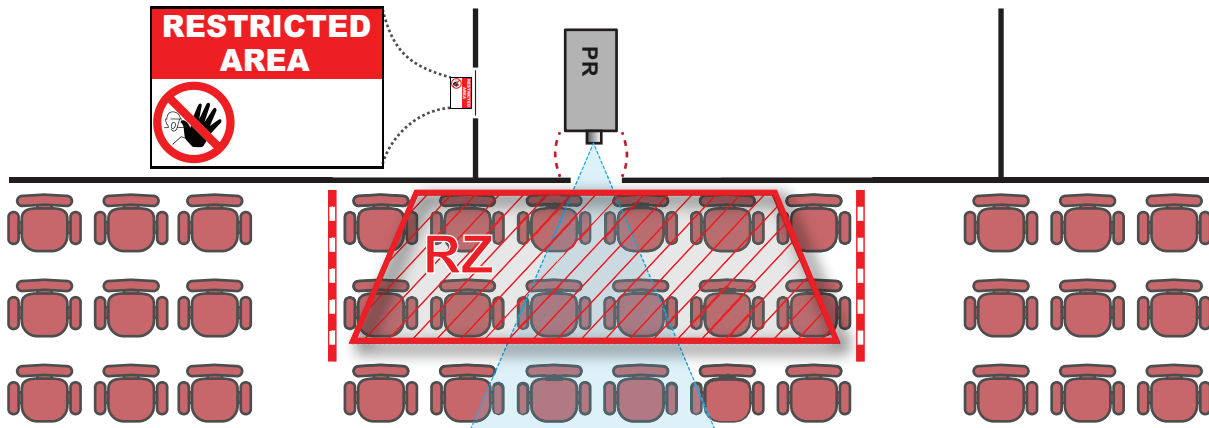

Image 1–3

USA market

For LIPs (Laser Illuminated Projectors) installed in the USA market other restriction zone conditions apply.

LIPs for installation in restrained environment (cinema theaters, business rooms, class rooms, museums ...) shall be installed at height vertically above the floor such that the bottom plane of the hazard distance zone shall be no lower than 2.5 meters above the floor. Horizontal clearance to the hazard distance zone shall be not less than 1 meter. Alternatively, in case the height of the separation barrier for the horizontal clearance is at least 1 meter high then the horizontal clearance (SW) can be reduced to:

- 0 meter if the height of the hazard zone is minimum 2.5 meter.
- 0.1 meter if the height of the hazard zone is minimum 2.4 meter.
- 0.6 meter if the height of the hazard zone is minimum 2.2 meter.

LIPs for installations in unrestrained environment (concerts, ...) shall be installed at a height vertically above the floor such that the bottom plane of the Hazard distance Zone shall be no lower than 3 meters above the floor. Horizontal clearance to the hazard distance zone shall be not less than 2.5 meters. Any human access horizontally to the Hazard Zone, if applicable, shall be restricted by barriers. If human access is possible in an unsupervised environment, the horizontal or vertical clearances shall be increased to prevent exposure to the hazard distance zone.

The LIP shall be installed by Barco or by a trained and Barco-authorized installer or shall only be transferred to laser light show variance holders. This is applicable for dealers and distributors since they may need to install the LIP (demo install) and/or they transfer (sell, rent, lease) the LIP. Dealers and distributors shall preserve sales and installation records for a period of 5 years. Variance holders may currently hold a variance for production of Class IIIB and IV laser light shows and/or for incorporating RG3 LIPs. Laser light show variance for RG3 LIPs can be requested by mailing the application to RadHealthCustomerService@fda.hhs.gov.

The installation checklist for laser illuminated RG3 projectors must be fully completed after the installation. The installation checklist can be downloaded from the Barco website. The installer shall preserve the checklist for a period of 5 years.

Install one or more readily accessible controls to immediately terminate LIP projection light. The power input at the projector side is considered as a reliable disconnect device. When required to switch off the projector, disconnect the power cord at the projector side. In case the power input at the projector side is not accessible (e.g. truss mount), the socket outlet supplying the projector shall be installed nearby the projector and be easily accessible, or a readily accessible general disconnect device shall be incorporated in the fixed wiring.

1.4.3 HD for fully enclosed projection systems

HD
 Hazard Distance (HD) is the distance measured from the projection lens at which the intensity or the energy per surface unit becomes lower than the applicable exposure limit on the cornea or on the skin. The light beam is considered (to be) unsafe for exposure if the distance from a person to the light source is less than the HD.

Restriction Zone (RZ) based on the HD

The projector is also suitable for rear projection applications; projecting a beam onto a diffuse coated projection screen. As displayed in Image 1–4 two areas should be considered: the restricted enclosed projection area (RA) and the observation area (TH).

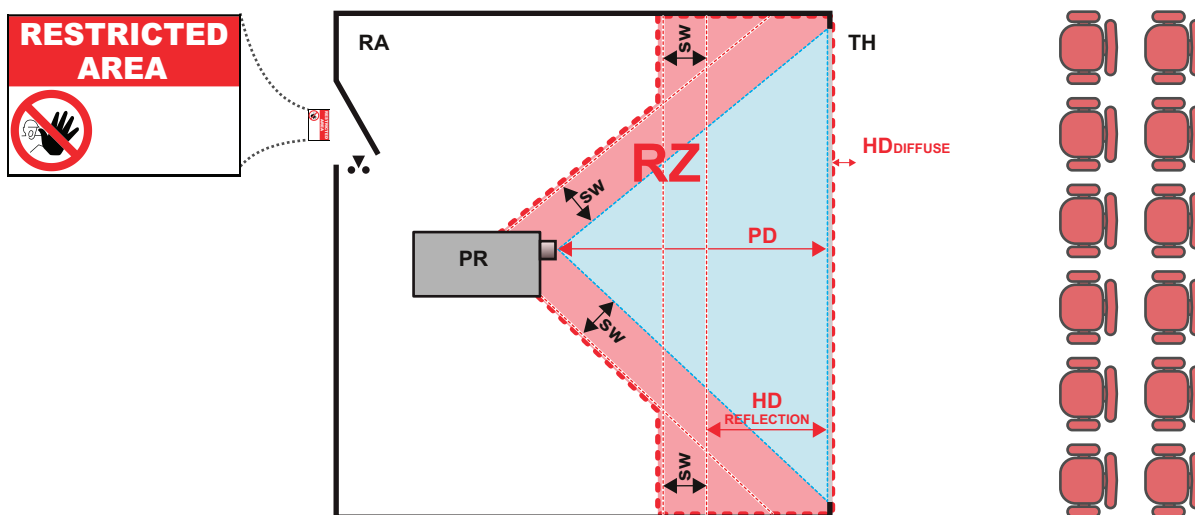

Image 1–4

- RA** Restricted Access location (enclosed projection area).
- PR** Projector.
- TH** Theater (observation area).
- RZ** Restriction Zone.
- PD** Projection Distance.
- SW** Separation Width. Must be minimum 1 meter.

For this type of setup 3 different HD shall be considered:

- HD as discussed in “High Brightness precautions: Hazard Distance”, page 17, relevant for intrabeam exposure.
- $HD_{\text{reflection}}$: the distance that has to be kept restrictive related to the reflected light from the rear projection screen.
- HD_{diffuse} : the relevant distance to be considered while observing the diffuse surface of the rear projection screen.

As described in “High Brightness precautions: Hazard Distance”, page 17, it is mandatory to create a restricted zone within the beam areas closer than any HD. In the enclosed projection area the combination of two restricted zones are relevant: The restricted zone of the projected beam toward the screen; taking into account 1 meter Separation Width (SW) from the beam onward. Combined with the restricted zone related to the rear reflection from the screen ($HD_{\text{reflection}}$); also taking into account a 1 meter lateral separation.

The $HD_{\text{reflection}}$ distance equals 25% of the difference between the determined HD distance and the projection distance to the rear projection screen. To determine the HD distance for the used lens and projector model see chapter “General considerations”, page 16.

$$HD_{\text{reflection}} = 25\% (HD - PD)$$

The light emitted from the screen within the observation shall never exceed the RG2 exposure limit, determined at 10 cm. The HD_{diffuse} can be neglected if the measured light at the screen surface is below 5000 cd/m² or 15000 LUX.

1.5 Regulatory

UK Compliance

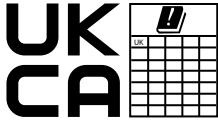

This product is fit for use in the UK.

Authorised Representative: Barco UK Ltd

Address: Building 329, Doncastle Road
Bracknell RG12 8PE, Berkshire, United Kingdom

L'information des consommateurs sur la règle de tri



FR
Cet appareil, ses accessoires, cordons et batteries se recyclent

REPRISE À LA LIVRAISON À DÉPOSER EN MAGASIN À DÉPOSER EN DÉCHÈTERIE

OU OU

Points de collecte sur www.quefairedemesdechets.fr
Privilégiez la réparation ou le don de votre appareil !

Product overview

2

2.1	Main unit.....	22
-----	----------------	----

2.1 Main unit

Component locations

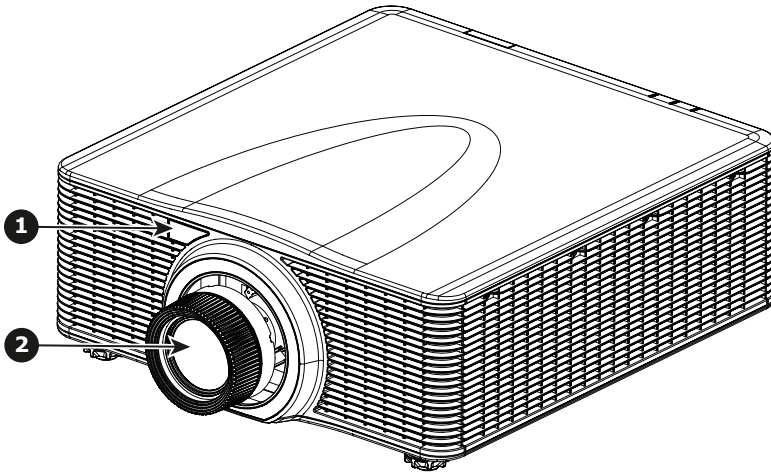

Image 2-1

- 1 Remote receiver (Front)
- 2 Projection lens

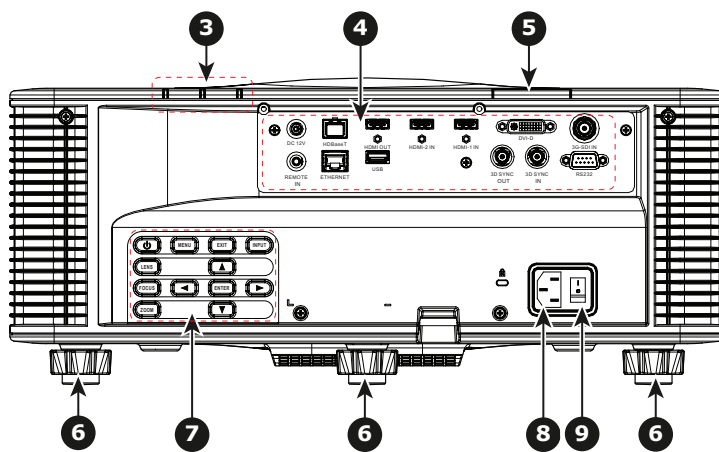

Image 2-2

- 3 LED Status Indicator
- 4 Input/Output (I/O) Panel
- 5 Remote receiver (Top)
- 6 Adjustable feet
- 7 Control panel
- 8 Power socket (AC100-240V, 50-60Hz)
- 9 Power switch

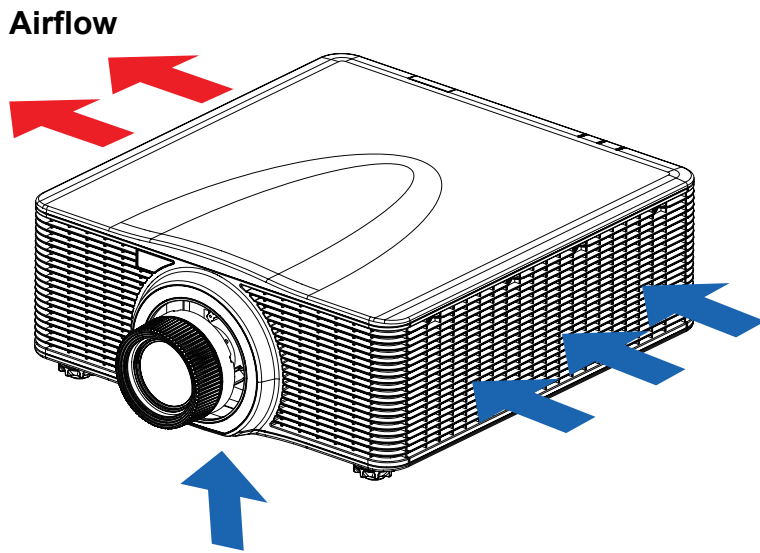

Image 2-3

Input & Communication

3

3.1	Input/Output (I/O) Panel	26
3.2	Control panel.....	26

3.1 Input/Output (I/O) Panel

Input and output ports location

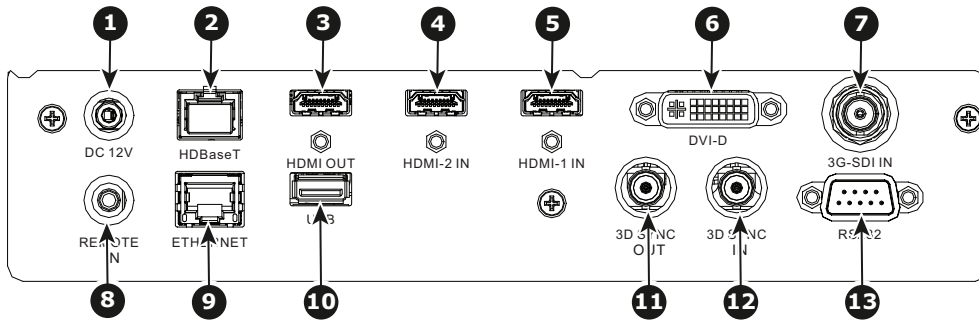

Image 3-1

- | | |
|---|--|
| <ul style="list-style-type: none"> 1 DC 12V connector 2 HDBaseT connector 3 HDMI out connector 4 HDMI 2 in connector 5 HDMI 1 in connector 6 DVI-D connector 7 3G SDI in connector | <ul style="list-style-type: none"> 8 Wired remote connector 9 Network connector RJ45 10 USB Type A connector 11 3D Sync out connector 12 3D Sync in connector 13 RS232 connector |
|---|--|

3.2 Control panel

Button location

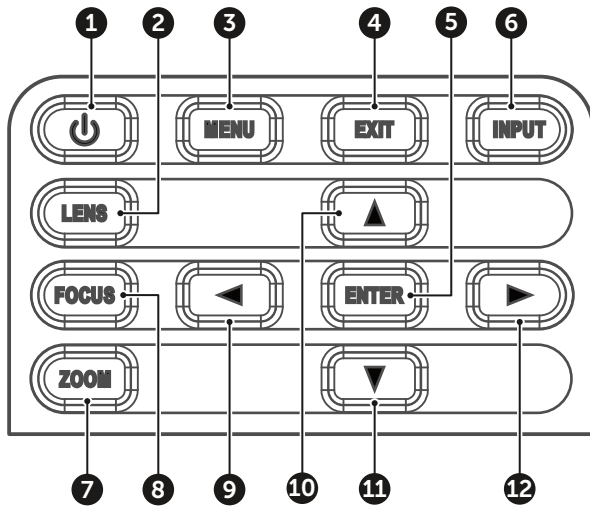

Image 3-2

- | | |
|---|---|
| <ul style="list-style-type: none"> 1 POWER 2 LENS 3 MENU 4 EXIT 5 ENTER 6 INPUT | <ul style="list-style-type: none"> 7 ZOOM 8 FOCUS 9 LEFT 10 UP 11 DOWN 12 RIGHT |
|---|---|

Button function

Button	Function
POWER	Turn the projector on or off.
LENS	Adjust lens position.
MENU	Show the main menu on screen.
EXIT	Return to previous menu or exit menu if at top level.

Button	Function
ENTER	Confirm the settings.
INPUT	Select an input source.
ZOOM	Adjust the image size.
FOCUS	Adjust the image focus.
LEFT	Navigate left through the menu.
UP	Navigate up through the menu.
DOWN	Navigate down through the menu.
RIGHT	Navigate right through the menu.

Remote Control Unit (RCU)

4

4.1	RCU battery installation	30
4.2	Overview of the RCU	31
4.3	Projector Address (ID).....	31
4.4	Using the RCU	32

4.1 RCU battery installation

How to install the batteries of the Remote Control Unit

1. Remove the cover by sliding it in the direction indicated by the arrow
2. Insert two new AAA batteries (observe the polarity).
3. Replace the cover.

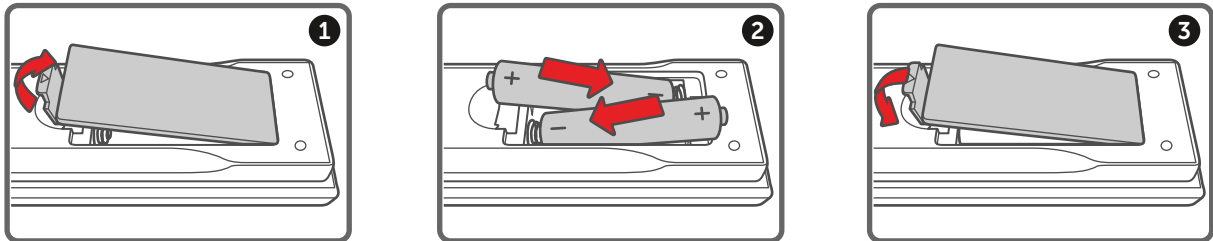

Image 4-1

Notes for the Remote Control Unit

- Be sure to insert the batteries in the corresponding orientations to match the polarities.
- Do not mix new batteries with used batteries as it would shorten the life of new batteries or cause leakage.
- Only used AAA batteries as instructed; do not attempt to insert different types of batteries into the remote control.
- If the remote is going to be unused for long periods of time, be sure to remove the batteries to prevent leakage, which could damage the remote control.
- The liquid contents in the batteries is harmful to the skin; do not touch the leakage with your bare hands directly. When installing fresh batteries, be sure to clean up the leakage thoroughly.
- Under most circumstances, you only need to point the remote control towards the screen and the IR signal would be reflected off the screen and picked up by the IR sensor on the projector. But under specific circumstances, the projector may fail to receive signals from the remote control due to environmental factors. When this happens, orient the remote control at the projector and try again.
- If the range of effective remote control signal reception decreases or if the remote control stops working, replace the batteries.
- If the infrared receiver is exposed to fluorescent lamp or strong sunlight, the remote control may not operate normally.
- Refer to the regulations enforced by your local government on the disposal of used batteries; improper disposal could damage the environment.

4.2 Overview of the RCU

Button identification

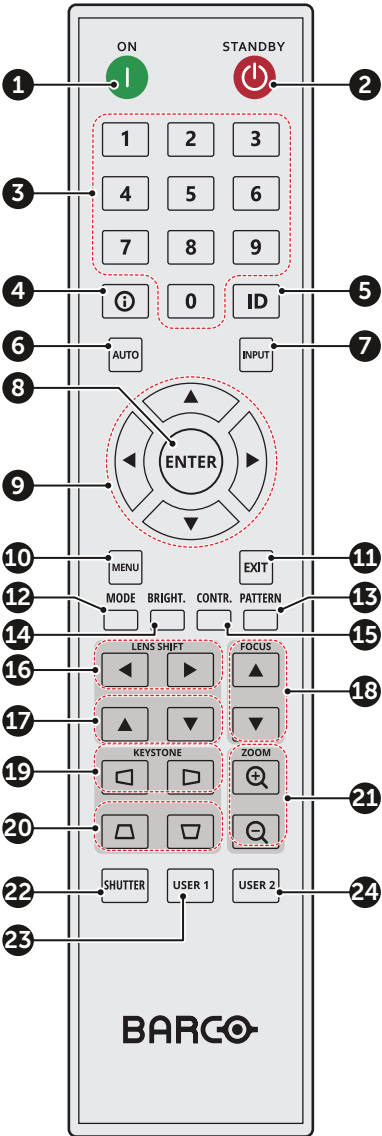
Button location	No.	Button	Function
	1	ON	Turn the projector on.
	2	Standby	Turn the projector off.
	3	Number	Input numbers (0-9)
	4	Info	Display information on the source image.
	5	ID	Set the projector address.
	6	Auto	Automatically synchronize the projector to an input source.
	7	Input	Select an input source manually.
	8	Enter	Confirm an selection.
	9	Arrow keys	Use arrow keys to navigate through the menu or select the appropriate settings.
	10	Menu	Show the main menu on the screen.
	11	Exit	Back to previous menu.
	12	Mode	Press to select the preset display mode.
	13	Pattern	Displays test patterns
	14	Brightness	Set the brightness of the image.
	15	Contrast	Set the contrast of the image.
	16	Lens shift H	Adjust the image position horizontally.
	17	Lens shift V	Adjust the image position vertically.
	18	Focus	Adjust the image focus.
	19	Keystone H	Adjust a horizontally keystone image.
	20	Keystone V	Adjust a vertically keystone image.
	21	Zoom	Adjust the image size.
	22	Shutter	Momentarily turn off/on the screen (AV Mute).
	23	User1	Press to assign custom functions. See user guide for more info.
	24	User2	Press to assign custom functions. See user guide for more info.

4.3 Projector Address (ID)

About the projector address

The Remote Control supports individual addressing of multiple projectors. The remote receiver on the projector can be set with a specific number from 00 to 99, and the projector only responds to the IR remote set

to the same number. The default ID code of the RCU (also known as the broadcast address) is 00. This specific address allows the RCU to control all projectors within its effective range.

How to set the projector address on the RCU

1. Keep **ID Key** pressed in.
2. After few seconds, enter the address with the numeric keys while keeping the **ID Key** pressed in.

 *Tip:* Always enter two digits. E.g. for address 2, enter 02.

3. Release the **ID Key**.



The projector address can be set in: *Communication > Remote setup > Remote code.*

4.4 Using the RCU

Effective range

The Infrared (IR) remote control sensors are located on the front and top sides of the projector. To have the remote control functions correctly, make sure of the following:

- The maximum range between the remote control and the sensor is 30 m (98.4 ft).
- Ensure to hold the remote at the following angles towards one of the IR remote control sensors:
 - horizontally: $\pm 30^\circ$
 - vertically: $\pm 20^\circ$
- Make sure there are no obstacles between the remote control and the IR sensors on the projector.
- Make sure the IR transmitter of the remote control is not directly being shined by sunlight or fluorescent lamps.
- Keep a minimum distance of 2 m between the remote control and nearby fluorescent lamps. If not, the RCU might malfunction.
- If the projector and remote are within very short distance, the RCU may become ineffective.
- When you aim at the screen, the effective distance is less than 5 m from the remote control to the screen and reflecting the IR beams back to the projector. However, the effective range might change depending on type of screen used.

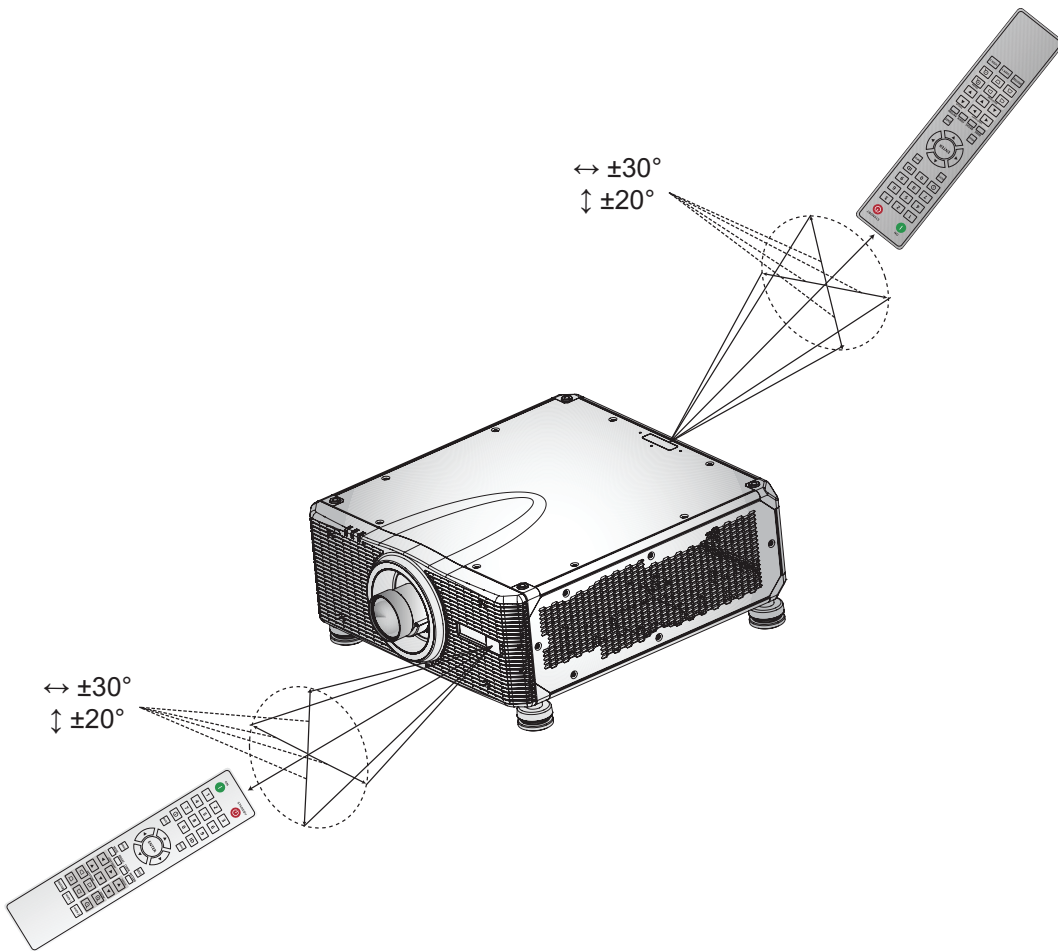

Image 4-2

Powering On/Off the projector

5

5.1	Powering On the projector	36
5.2	Powering Off the Projector.....	36



This chapter assumes that the power cord and (all) signal cables are securely connected. For detailed instructions see installation manual.

5.1 Powering On the projector

How to power On the projector

1. Power on the AC switch (1) and wait until the power button on the control panel is solid red.

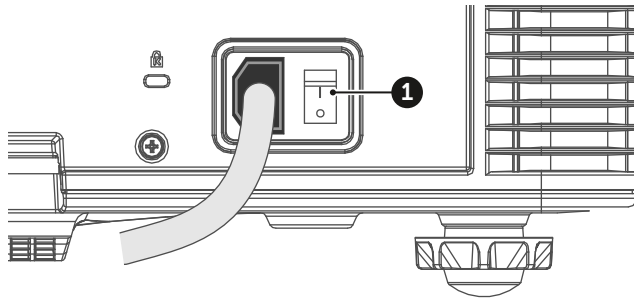

Image 5-1

2. Turn on the projector by pressing the POWER button (2) on the control panel or the ON key (3) on the remote control.



Image 5-2

The status LED (4) will flash orange. The startup screen will display and the status LED will turn to solid green.

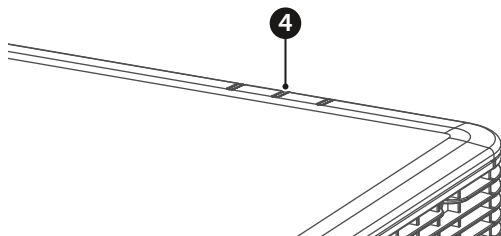

Image 5-3

3. Turn on your source. The projector detects the source you selected and displays the image.



Note: If you connect multiple sources at the same time, press “Input” key on the control panel or on the remote control to switch inputs.



WARNING: Do not look directly into the lens when the projector is turned on. The strong light might cause permanent eye damage.

5.2 Powering Off the Projector

How to power Off the projector

1. Press the POWER button (2) on the control panel or the OFF key (5) on the remote control, a message displays on the screen.

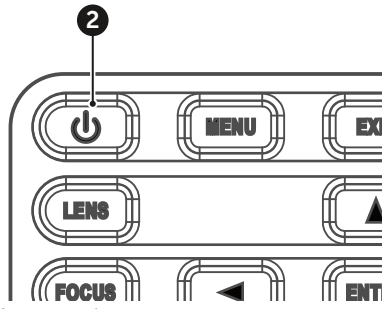
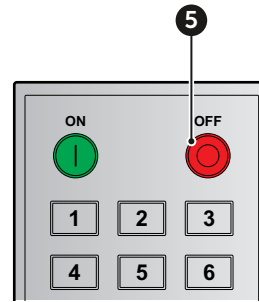

Image 5-4



2. Press the POWER button or OFF key again to confirm, otherwise the message disappears after 5 seconds and the projector remains on.



CAUTION: Don't turn on the projector immediately after entering Standby mode.

User controls

6

6.1 On-Screen Display Menus.....40

6.1 On-Screen Display Menus

About OSD

The projector has On-Screen Display (OSD) menus that allow you to make image adjustments and change a variety of settings.

Follow the steps below to use the OSD menu to configure the projector settings.

How to operate

1. To open the OSD menu, press **Menu** key on the control panel or remote control.
2. Use arrow keys to navigate through the menus and select appropriate settings.
3. Press **Enter** to enter the submenu or confirm a setting.
4. Press **Exit** to return to the previous menu or exit OSD menu if at top level.

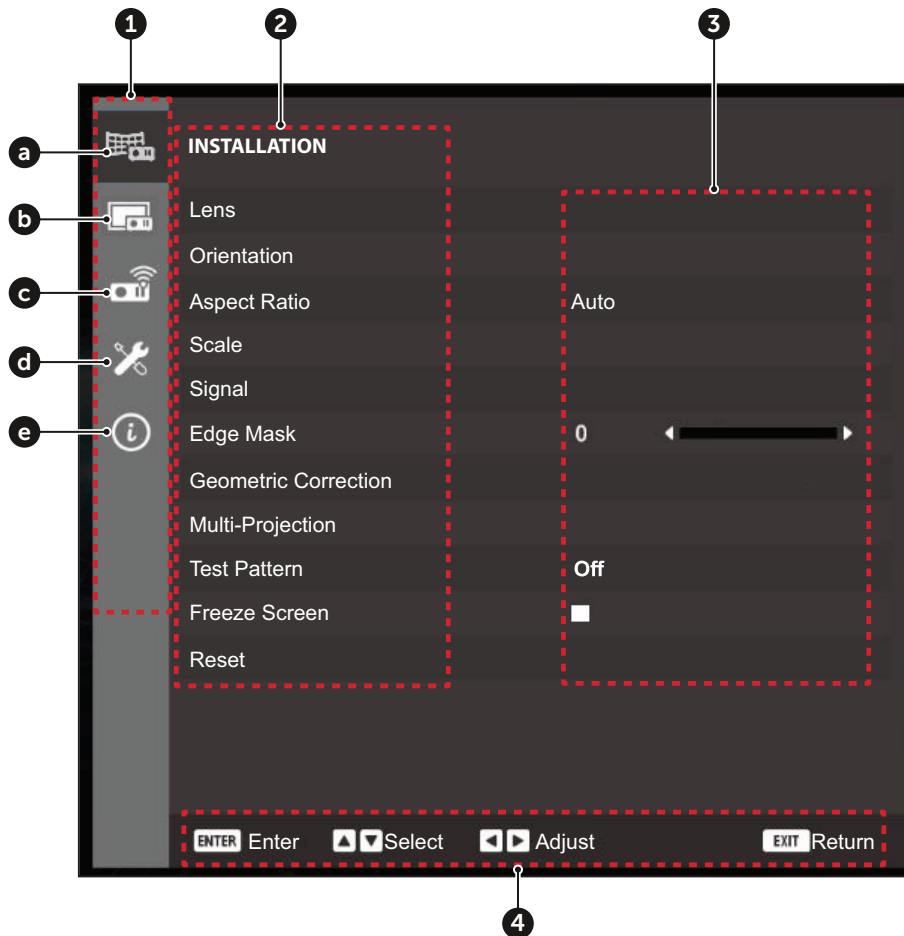

Image 6-1

- | | | | |
|---|----------------|---|-----------------|
| 1 | Main menu | b | Image settings |
| 2 | Sub menu | c | Communication |
| 3 | Settings | d | System settings |
| 4 | Navigation bar | e | Information |
| a | Installation | | |

User controls — Installation

7

7.1	Lens	43
7.2	Orientation	43
7.3	Aspect Ratio.....	44
7.4	Scale	44
7.5	Signal	44
7.6	Edge Mask.....	46
7.7	Geometry Correction	46
7.8	Multi-Projection	48
7.9	Test Pattern.....	49
7.10	Freeze Screen.....	50
7.11	Reset.....	50

Overview

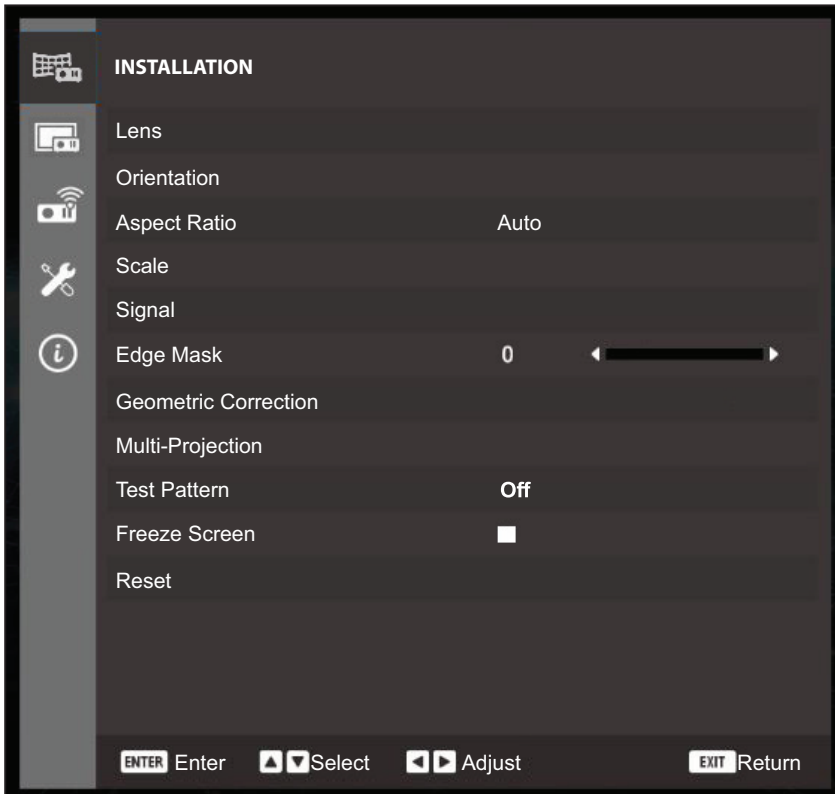

Image 7-1

7.1 Lens

About lens settings

Configure the lens settings to adjust the image quality and position.

Focus

Adjust the focus of the image.

Zoom

Adjust the size of the projected image.

Lens Shift

Adjust the lens position to shift the projected area.



CAUTION: For UST lens mounted in its support, do not execute any lens movements when the UST lens is fixed in the Lens Support.

Lens Memory

This projector can save up to five lens settings.

- **Save Memory:** Select a record from 1 to 5 to save the current lens settings.
- **Apply Memory:** Select a record from 1 to 5 to apply the lens settings.
- **Clear Memory:** Clear the saved lens records.

Lens Calibration

Calibrate the lens position to return it to the center. To prevent damage to the projector and the lens, always perform lens calibration before replacing the lens.

Lens Lock

Lock the lens to prevent the lens motors from moving, which disables all lens functions.

Reset

Reset the function settings to factory default values.

7.2 Orientation

About orientation

Configure the projection orientation according to the projector's installation direction.

Ceiling Mount

Enable the function for ceiling mount installation.

Direction

Select *Front Projection* or *Rear Projection* based on the projector's relative position to the screen.

7.3 Aspect Ratio

Possible aspect ratios

Set the aspect ratio of the projected image. The available options are:

- Auto (default)
- 4:3
- 16:9
- 16:10
- Letter boxing
- Native

Select *Auto* to display the detected image size.

7.4 Scale

About scale

Digitally scale the image size and position to fit onto the actual projection surface.

Digital Zoom

Digitally adjust the size of the projected image.

- **Horizontal:** Change the width of the projected image.
- **Vertical:** Change the height of the projected image.

Digital Shift

Adjust the position of the display area within the lens offset range. You need to digitally zoom the image before using the Digital Shift function.

- **Horizontal:** Horizontally shift the image.
- **Vertical:** Vertically shift the image.

Reset

Reset the function settings to factory default values.

7.5 Signal

About signal

Configure the settings to correctly project the input signals and transfer the output signals.

Auto Signal

When Auto Signal is enabled, the projector automatically detects and selects the input signal. Once an input source is selected, press the Input button on the remote control or keypad to switch to other available sources.

Backup Input

Backup Input function allows the user to set up two input sources with the same timing specification. Upon loss of one input source, the projector automatically switches to the other source.

This function can be useful for the installations requiring uninterruptedly displaying the content source, such as live show, exhibition, and critical control room.

- **Auto Switch:** Check the box to enable automatically switch to backup input source when the current source fails.
- **Current Signal:** Displays the current active signal.

- **First Input:** Select a signal as the first input source. Once the selected source is activated, the OSD menu lists out the signal's Resolution, Horz Refresh (horizontal refresh rate), and Color Space.
- **Second Input:** Select a signal as the second input source. Once the selected source is activated, the OSD menu lists out the signal's Resolution, Horz Refresh (horizontal refresh rate), and Color Space
- **Backup Input Status:** Display the function status. The Backup Input Status is active when meeting the following conditions:
 - Auto Switch is checked.
 - The two sources are with the same timing specification.
 - The two sources are active.
 - Projector is displaying one of the two sources.

Note on backup input function:

- Only HDMI1, HDMI2, DVI, and HDBaseT inputs support the Backup Input function. The 3G-SDI input does not support the Backup Input function.
- To activate the Backup Input function, the conditions below must be met between two backup input sources (**First Input** and **Second Input**): **Resolution**, **Horz Refresh** (horizontal refresh rate), **Color Space**, and **HDR** data must be the same.

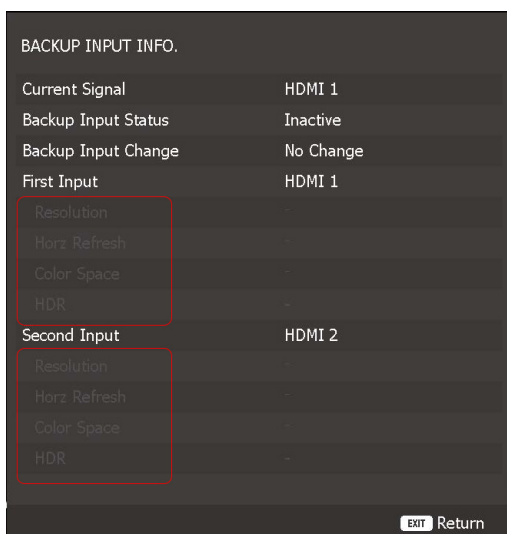

Image 7-2

- If the conditions above are met, the Backup Input Status option in the OSD menu will show "Active".

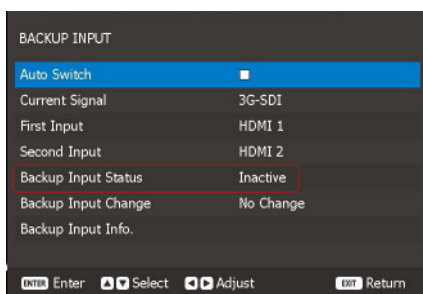

Image 7-3

Example cases backup input

Case 1: backup input active with splitter



Image 7-4

- Useful for displaying uninterruptedly content in live show, exhibition and critical control rooms.
- Backup Input Status is Active in same Resolution, Color Space and close Horizontal refresh.

- Backup input source (HDMI1/ HDMI2 / HDBaseT / DVI)

Case 2: different input source (without splitter)



Image 7-5

- 2 input sources, HDMI1 and HDMI2
- When Backup Input Status is active, auto switch to HDMI2 seamlessly when HDMI1 is lost.
- Due to Resolution/Color space/ Horizontal Refresh difference between two input sources, in some case, auto switch and resync may take seconds from HDMI1 to HDMI2 when HDMI1 signal is lost.

HDMI

Setup the projector's HDMI ports.

- **Output:** Select a HDMI port to output the signal.
- **EDID:** When receiving a HDMI signal, set the projector's EDID compatibility to display the signal correctly. Select 1.4 for the input devices with HDMI 1.4, or 2.0 for HDMI 2.0 devices.

Auto Signal Resync

Once enabled, the system will automatically synchronize the projector to the recent connected input source every time you switch the input source.

7.6 Edge Mask

About edge mask

The edge blending function allows you to hide one or multiple edges of the projected image. You can use this function to remove the video encoding noise on the edges of the video images.

7.7 Geometry Correction

About geometry correction

Configure the geometry settings to reshape the image for different projection surface.

Warp control

Configure warp settings.

- **Basic:** Configure basic settings, such as keystone, pincushion, and 4-corner.
- **Advanced:** Configure advanced settings, such as grid points, warp inner, warp sharpness, and more.

Basic Warp

Configure basic warp settings.

- **Keystone:** Keystone function is used to adjust the images in asymmetric rectangle shape.
 - **H. Keystone** : Adjust the left and right side of the projected image to make it an even rectangle. It is used for the images with unequal left and right sides.

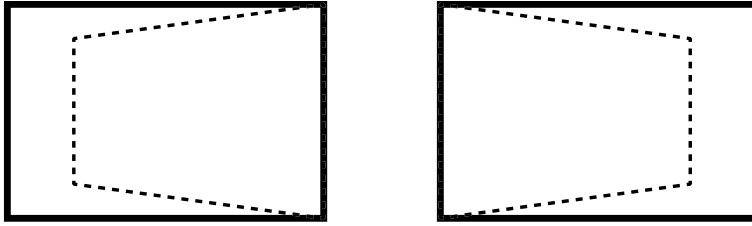

Image 7-6

- **V. Keystone** : Adjust the top and bottom side of the projected image to make it an even rectangle. It is used for the images with unequal top and bottom sides.

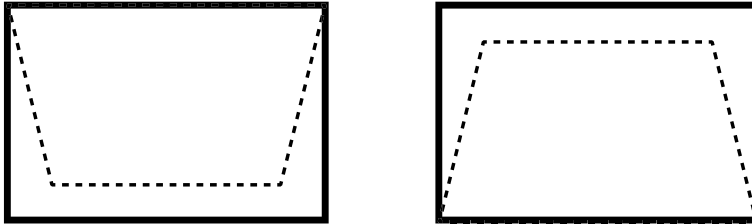

Image 7-7

- **Pincushion**: Pincushion function is used to adjust the image with barrel or pincushion distortion.
 - **Horizontal**: Correct the projected image with horizontal barrel or pincushion distortion

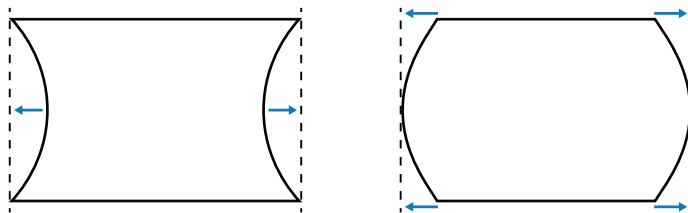

Image 7-8

- **Vertical**: Correct the projected image with vertical barrel or pincushion distortion.

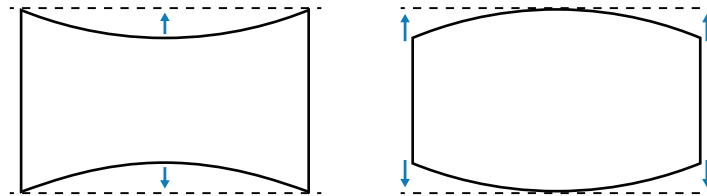

Image 7-9

- **4 - corner** : Reshape the image by moving the 4 corners of the image to have it fit a specific projection surface.

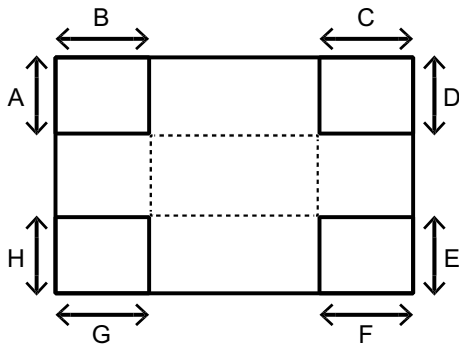

Image 7-10

Advanced Warp

Configure advanced warp settings.

- **Grid Points:** Set the grid points of warp pattern.
- **Warp Inner:** Enable or disable warp inner control.
Note: the warp inner does not support 2x2 grid points.
- **Warp Sharpness:** When the grid lines are warped from straight into curve, the grid lines will be distorted and become jagged. To avoid the line jagged are too obvious, users can adjust the warp sharpness to blur or sharpen the edge of the images.
- **Grid Color:** Select a grid color for warp and blend pattern.
- **Grid Background:** Select the grid background.
- **Blend Setting:** Configure the blend settings directly on the projector to merge two or more adjacent images into one larger and seamless image.
 - **Blend Width:** Set the blend pattern width.
 - **Overlap Grid Number:** Set the blend overlap grid number.
 - **Gamma:** Set the gamma value of the blend area to adjust the curvature of the blending effect.

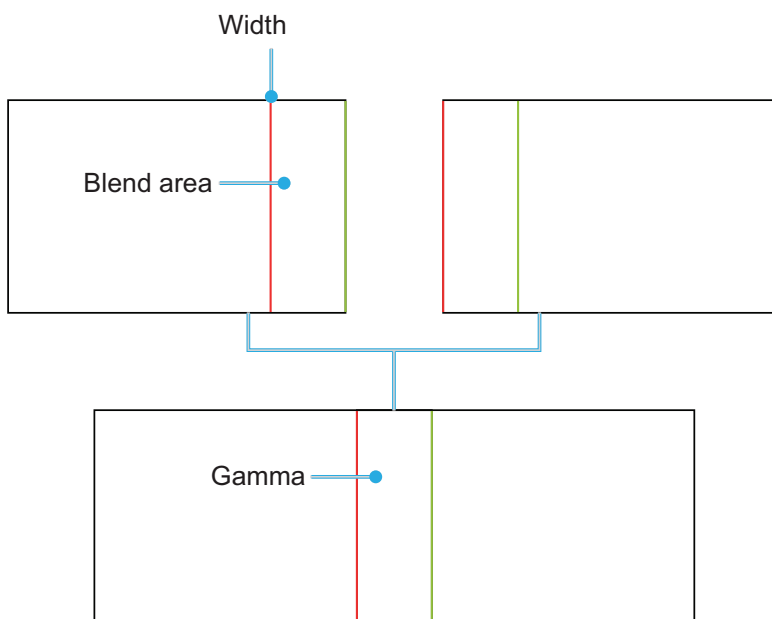

Image 7-11

Memory

The projector allows the user to save up to five geometry memories, including the ones set directly on the projector and the ones configures via external software tool. The available options are Save Memory, Apply Memory, and Clear Memory.

Reset

Reset the geometry settings to factory default values.

7.8 Multi-Projection

About multi-projection

Multi-Projection is a submenu group that consists of the functions for multiple projector applications.

Projector ID

Set the identification code for each projector.

Remote Code

Set the remote code for each remote control to have it matching with the projector.

3D Setup

Configure the 3D settings for each projector when performing 3D warp and blend.

Light Source Settings

Configure the light source settings for the projectors to have their brightness level matching with each other.

Color Mode

Set the projectors to the same color mode.

White Balance

Adjust the white color performance of the projectors to have them look as the same as possible.

Advanced Color

Adjust the advanced color settings of the projectors to unify the color performance.

Lens

Set up the lens of each projector to adjust the image focus, size, and position.

Scale

Digitally change image size and position of each projector.

Geometry Correction

Configure the geometry settings for each projector.

7.9 Test Pattern

About test pattern

Select a test pattern. The available options are:

- Off,
- Green Grid,
- Magenta Grid,
- White Grid,
- White, Black,
- Red,
- Green,
- Blue,
- Yellow,
- Magenta,
- Cyan,
- ANSI Contrast 4x4,
- Color bar,
- Full screen

7.10 Freeze Screen

About freeze screen

Select to pause the display screen despite any change in the source device.

7.11 Reset

About reset

Reset all the installation settings to factory default values.

User control — Image menu

8

8.1	Color Mode	52
8.2	Brightness.....	52
8.3	Contrast.....	52
8.4	Saturation	52
8.5	Tint.....	52
8.6	Sharpness	52
8.7	Gamma	53
8.8	White Balance	53
8.9	Advanced Color.....	53
8.10	Advanced Image	55
8.11	Save to User	57
8.12	Apply to User	57
8.13	Reset.....	57

8.1 Color Mode

About color mode

There are a number of color modes that are preset for different types of images.

- **Presentation:** Best for displaying presentation slides in a bright room.
- **Bright:** Best for the installations requiring high brightness images.
- **Super Bright:** Best for images with the brightness above the standard level.
- **Cinema:** Best for videos projected in a dark room.
- **HDR:** Best for displaying High Dynamic Range (HDR) content.
- **sRGB:** Standardized image color that matches the sRGB color standard.
- **DICOM SIM.:** Best for projecting monochrome medical images, such as X-ray diagram.
- **Blending:** Best for multiple projector installations.
- **3D:** Best for playing 3D videos.
- **2D High Speed:** This mode is used for displaying 2D input signal at 120Hz.
- **User:** Image settings saved by the user.

8.2 Brightness

About brightness

Adjust the luminous brightness of the projected image to adapt to different ambient light.

8.3 Contrast

About contrast

Adjust the contrast ratio of the projected image. The contrast controls the degree of difference between the lightest and darkest parts of the image.

8.4 Saturation

About saturation

Adjust the intensity of the image colors.

8.5 Tint

About tint

Adjust the color balance of red and green in video images.

8.6 Sharpness

About sharpness

Adjust the clarity of details in the projected image to make the image clearer and sharper.

8.7 Gamma

About gamma

Adjust the gamma levels of the image. The available options are:

- 1.8,
- 2.0,
- Standard 2.2,
- 2.4,
- 2.6,
- Graphic,
- Video,
- CRT(Vivid),
- Enhanced (default),
- Film,
- DICOM

In general, the smaller the value, the brighter the dark areas of the image will become.

8.8 White Balance

About white balance

Adjust the overall tint of the image to optimize the white color performance.

Color Temperature

Select the color temperature of the projected image. The available options are:

- Warm,
- Standard (default),
- Cool

Gain/Offset (RGB)

Gain and offset are individual controls for each RGB channels used to set grey scale. The Gains calibrate the color of the dark parts and Bias calibrate the white parts.

- **Red / Green / Blue Gain:** Adjust the color of the image's bright areas.
- **Red / Green / Blue Offset:** Adjust the color of the image's dark areas.

White Peaking

Adjusts the image color brightness while providing more vibrant colors, in increments from 0 to 10.

Reset

Reset the function settings to factory default values.

8.9 Advanced Color

About advanced color

Configure advanced color settings to improve the color performance.

Color Space

Select a color space that has been specifically tuned for the input signal. The available options are:

- Auto (default),
- RGB (0 - 255),

- RGB (16 - 235),
- REC709,
- REC601

Wall Color

Set the wall color of the projector to achieve best color performance for a specific wall. The available options are:

- Off (default),
- Blackboard,
- Light Yellow,
- Light Green,
- Light Blue,
- Pink,
- Gray

If *Auto Wall Color* is selected, the projector automatically adjust the image color to fit the color of the projection screen. The auto adjustment is performed via the built-in camera. Please make sure the camera is not covered by any subjects.

Custom RGBCMY

Change the color of a projected image by adjusting each color component in the image. The adjustable color includes Red, Green, Blue, Cyan, Yellow, and Magenta (R / G / B / C / Y / M).

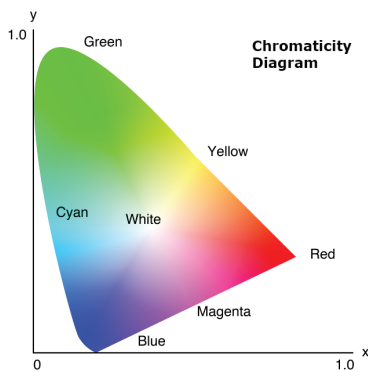

Image 8-1

- **Auto Test Pattern:** Enable the function to view a specific color pattern while adjusting.
- **R / G / B / C / M / Y:** Select a color for further adjustment.
- **Hue:** Adjust the hue of the selected color. The value reflect the number of degrees of rotation around the chromaticity diagram from the original color. Increasing value indicates counterclockwise rotation, and decreasing value, clockwise rotation.
- **Saturation:** Adjust the saturation of the selected color. The value indicates the color shifts from or towards the white in the center of the chromaticity diagram.
- **Gain:** Adjust the gain of the selected color. Increase the value to brighten the image (add white to a color) or decrease the value to darken the image (add black to a color).
- **Reset:** Reset the function settings to factory default values.

Custom White

Adjust the white color performance via setting the Red, Green, and Blue values.

- **Auto Test Pattern:** Enable the function to view the white color pattern while adjusting.
- **Red / Green / Blue:** Adjust the red, green, and blue colors to optimize the white color performance.
- **Reset:** Reset the function settings to factory default values.

8.10 Advanced Image

About advanced image

Configure advanced image settings to correctly project specific image formats for more complicated applications.

Dynamic Contrast

Set up the Dynamic Contrast to maximizing the contrast for dark content.

- **Dynamic Black:** Enable the function to automatically adjust the contrast ratio for video sources. It improves the black level in dark scenes by reducing the light output.
 - **Speed:** Adjust the speed of the light source correction. The value ranges from 1 to 15. A lower value makes the correction slower and less aggressive while a higher value results in the faster correction.
 - **Strength:** Set the strength of the dynamic contrast adjustment. The value ranges from 0 to 3, the higher the value the stronger the correction.
 - **Level:** Adjust the light source when the brightness level of the current content gets lower than the set value. The value ranges from 50% to 100%. The higher the value, the larger the range to adjust the light source.
- **Extreme Black:** Enable the function to automatically automatically increase the contrast ratio by turning off the laser light when black image is detected.
 - **Light Out Timer:** Set a timer for the laser light to turn off after detecting black content. The set value ranges from 0s to 20s.
 - **Light Out Signal Level:** Set a black level value as the threshold for the Real Black function. The value can be selected from 0 to 5, with 0 being the darkest black and 5 being the brightest.
- **Reset:** Reset the function settings to factory default values.

3D Setup



3D video file combines two slightly different images (frames) of the same scene representing the different views that the left and right eyes see. When these frames are displayed fast enough and viewed with 3D glasses synchronized with the left and right frames, the viewer's brain then assemble the separate images into a single 3D image. 3D Menu provides options to set up the 3D functions to correctly display 3D videos.

- **3D Mode:** Enable or disable the 3D function.
- **3D Format:** Select a proper 3D format for the 3D input signal. The available options are Auto, Frame Packing, Side by Side, Top and Bottom, and Frame Sequential.
- **3D Tech:** Select a proper 3D technology according to how the 3D sync signal is processed.
 - **DLP-Link:** Select DLP-Link when the 3D sync signal is generated by the DLP Link technology built-in the projector. DLP Link works only with the glasses that are compatible with DLP 3D technology and the 3D function is enabled
 - **3D Sync:** Select 3D Sync when the 3D sync out signal is sent to an emitter or another projector through the 3D sync out port.
- **3D-2D:** Transform the 3D content to 2D images.
 - **3D:** Play the 3D content normally.
 - **2D-Left:** Play the left images of the 3D content.
 - **2D-Right:** Play the right images of the 3D content.
- **3D Sync Out:** Set up the transmission of the 3D sync output signal.
 - **To Emitter:** Send the 3D sync signal to the emitter connected to the 3D sync out port.
 - **To Next Projector:** Send the 3D sync signal to next projector when using multiple projectors.
- **3D Invert:** When the 3D video does not appear correctly, use this function to invert the 3D left and right frames.
- **Frame Delay:** Set a frame delay value for the projector to correct the time difference between the 3D signal being given and the result being executed. This function works only when L/R Reference is set to Field GPIO. When performing 3D blending on multiple projectors, set the frame delay for each projector to correct the non-synchronous images.
- **Reset:** Reset the function settings to factory default values.





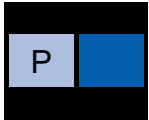

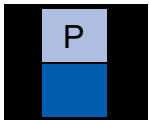
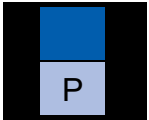





PIP / PBP

PIP/PBP (picture in picture/picture by picture) allows simultaneously displaying two images from two input sources.

- **PIP/PBP:** Select the appropriate PIP/PBP mode or disable the function.
 - **Off:** Disable PIP/PBP mode.
 - **PIP:** Display one input source on the main screen and the other input source in an inset window.
 - **PBP:** Display two images of the same size on the screen.
- **Main Source:** Select an input source for the main image. The available input sources are HDMI1, HDMI2, DVI-D, 3G-SDI, and HDBaseT.
- **Sub Source:** Select an input source for the second image. The available input sources are HDMI1, HDMI2, DVI-D, 3G-SDI, and HDBaseT.
- **Swap Source:** Swap the main source and sub source.
- **Sub Image Size:** Change the display size of the sub source in PIP mode.
- **Sub Position:** Adjust the position of the sub image. In the layout chart below, the "P" indicates the main image:
 - **PBP Layout**

PBP Layout	
<p>PBP, Main Left</p> 	<p>PBP, Main Right</p> 
<p>PBP, Main Top</p> 	<p>PBP, Main Bottom</p> 

- **PIP Layout**

PIP Layout	PIP Size		
	Small	Medium	Large
PIP, Bottom Right			
PIP, Bottom Left			
PIP, Top Left			
PIP, Top Right			

- **PIP/PBP Compatibility**

PIP/PBP Matrix	HDMI-1	HDMI-2	DVI-D	3G-SDI	HDBaseT
HDMI-1	—	V	V	V	V
HDMI-2	V	—	V	V	V

PIP/BPB Matrix	HDMI-1	HDMI-2	DVI-D	3G-SDI	HDBaseT
DVI-D	V	V	—	V	V
3G-SDI	V	V	V	—	V
HDBaseT	V	V	V	V	—

- **Sub Brightness:** Adjust the luminous brightness of the sub image to adapt to different ambient light.
- **Sub Contrast:** Adjust the contrast ratio of the sub image.
- **Sub Color Space:** Select a color space for the sub image.

Dynamic Range

Configure the settings for the High Dynamic Range (HDR) function.

- **HDR**
 - **Off:** Turn off the projector's HDR function, and the projector announces that it does not support HDR content so that the input device only sends out SDR signals.
 - **Auto:** When receiving HDR signals, the projector automatically changes to HDR display mode.
- **HDR Picture Mode**
 - **Bright:** Increase the color saturation for bright images.
 - **Standard:** Make the images look more realistic and natural.
 - **Film:** Improve the image details for videos.
 - **Detail:** Improve image details in dark scenes.

Low Latency

Use this function to enable/disable the system to reduce response times (input latency) during gaming.

- **Normal:** Without reduce the latency.
- **2D Ultra:** Reduce the latency of image that can display image simultaneously.

8.11 Save to User

About save to user

Save the image settings to the User Mode. Select the correct format according to the image format, which includes 2D Image, 3D Image, and Blending Image.

8.12 Apply to User

About apply to user

Apply the image settings to User-Presentation, User-Bright, User-Super Bright, User-Cinema, User-HDR, User-RGB, User-DICOM SIM., User-Blending, User-3D, or User-2D High Speed.

8.13 Reset

About reset

Reset all the image settings to factory default values.

User controls — Communication menu

9

- 9.1 Projector ID 60
- 9.2 Remote Setup 60
- 9.3 Network Setup 60
- 9.4 Control 61
- 9.5 Using the web control center 62
- 9.6 Using RS232 command by Telnet 63
- 9.7 Baud Rate 63
- 9.8 Reset 64

9.1 Projector ID

About projector ID

Assign an remote code for the projector from 00 to 99. Use this code as the projector ID when controlling the projector by RS232, HDBaseT, Telnet or other control methods.

9.2 Remote Setup

About remote setup

Configure the settings of the Infra-Red (IR) remote control.

Remote code

Assign an remote code from 00 to 99 for the remote receivers on the projector. The projector only responds to the IR remote control set with the same remote code.

Remote receiver

Set the remote receiver for the projector to control the communication between the projector and the IR remote.

- **Front:** Enable or disable the front remote receiver.
- **Top:** Enable or disable the top remote receiver.
- **HDBaseT:** Select **On** to set the HDBaseT terminal as the remote receiver.

User Button 1 / User Button 2

Assign a function to the User 1 / User 2 button on the remote control. It allows you to use the function easily without going through the OSD menus. The available functions for the User 1 / User 2 button are:

- Freeze Screen
- Blank Screen
- Save to User
- PIP/PBP
- Aspect Ratio
- Show Message
- User Data
- Network Setup
- Projector ID
- Orientation
- Custom RGBCMY
- Multi-Projection
- Reset Selective

9.3 Network Setup

About network setup

Configure the projector's network settings.

Ethernet

Configure the projector's Ethernet settings when connecting to a wired network using an RJ-45 cable.

- **RJ-45:** Specify the LAN interface to RJ-45.
- **HDBaseT:** Specify the LAN interface to HDBaseT.
- **MAC Address:** Display the MAC address. (Read only)
- **Network Status:** Display the network connection status. (Read only)

- **DHCP:** Turn on DHCP to automatically acquire IP address, subnet mask, gateway, and DNS.
- **IP Address:** Assign the projector's IP address.
- **Subnet Mask:** Assign the projector's subnet mask.
- **Gateway:** Assign the projector's gateway.
- **DNS:** Assign the projector's DNS.
- **Apply:** Apply the wired network settings.

Reset

Reset all network settings to default factory values.

9.4 Control

About control

This projector can be controlled remotely by a computer or other external devices through wireless or wired network connection. It allows the user to control one or more projectors from a distant control center, such as powering the projector on or off, and adjusting the image brightness or contrast.

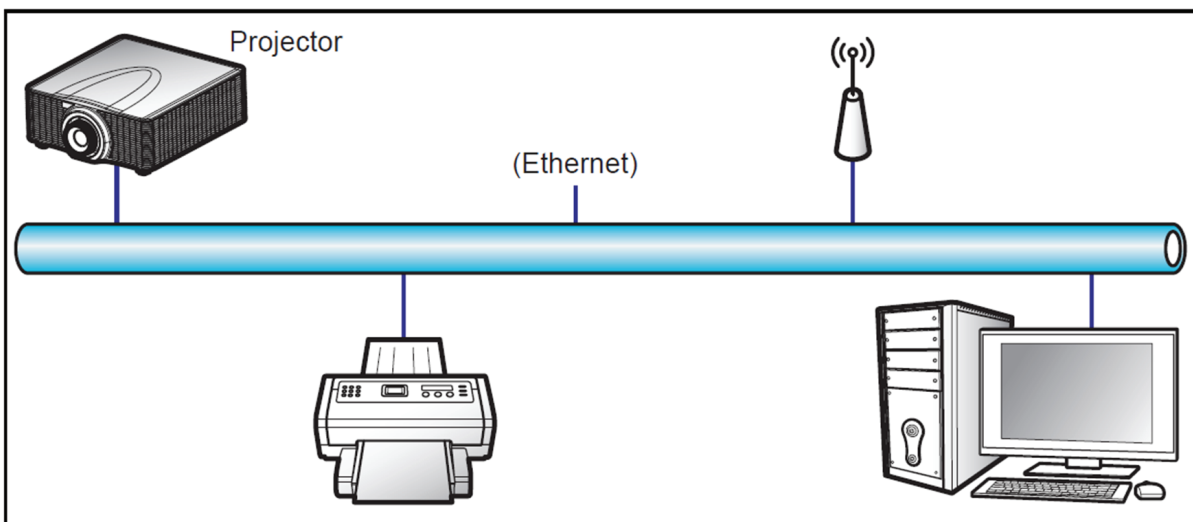

Image 9-1

Crestron

Control the projector with Crestron controller and related software. (Port: 41794)

You can configure the IP Address, IPID, and Port for the network connection. For more information, please visit <http://www.crestron.com>.

Extron

Control the projector with Extron devices (port 3023).

For more information, please visit <http://www.extron.com>.

PJ Link

Control the projector with PJLink v1.0 commands (port 4352).

You can configure the IP Address (Service) for the network connection. For more information, please visit <http://pjlink.jbmia.or.jp/english>.

AMX

Control the projector with AMX devices (port 9131).

For more information, please visit <http://www.amx.com>.

Telnet

Control the projector using RS232 commands through Telnet connection (port 3023).

HTTP

Control the projector with web browser (port 80).

Reset

Reset the function settings to default factory values.



- Crestron is a registered trademark of Crestron Electronics, Inc. of the United States.
- Extron is a registered trademark of Extron Electronics, Inc. of the United States.
- AMX is a registered trademark of AMX LLC of the United States.
- PJLink applied for trademark and logo registration in Japan, the United States of America, and other countries by JBMIA.
- For more information about the various types of external devices which can be connected to the LAN/ RJ45 port and remotely control the projector, as well as the supported commands for these external devices, please contact the Support-Service directly.

9.5 Using the web control center

About web control center

Web control panel allows the user to configure various projector settings using a web browser from any personal computer or mobile devices.

System requirement

To use the web control panel, make sure your devices and software meet the minimum system requirements.

- RJ45 cable (CAT-5e) or wireless dongle
- PC, laptop, mobile phone, or tablet installed with a web browser
- Compatible web browsers:
 - Internet Explorer 11 or higher version
 - Microsoft Edge 40 or higher version
 - Firefox 57 or higher version
 - Chrome 63 or higher version
 - Safari 11 or higher version
- Operating system of the mobile devices:
 - iOS 10 or higher version
 - Android 5 or higher version

Accessing the web control panel

When network is available, connect the projector and the computer to the same network. Use the projector address as the web URL to open the web control panel in a browser.

1. Check the projector address using the OSD menu.
 - In a wired network, select *Communication > Network Setup > Ethernet*.
 - Make sure *DHCP* is enabled.
 - Select *IP Address*
 - In a wireless network, select *Communication > Network Setup > Wireless > IP Address*.
2. Open a web browser and type the projector address in the address bar and confirm.

The web page redirects to the web control panel.



When network is not available, see *Directly connect the projector to a computer*.

Directly connect the projector to a computer

When a network is not available to you, connect the projector to you computer directly using a RJ-45 cable, and configure the network settings manually.

1. Assign IP address to the projector
 - In the menu, select *Communication > Network Setup > Ethernet*.
 - Turn off DHCP, and manually set the projector's IP Address, Subnet Mask, and Gateway.
 - Press **Enter** to confirm the settings.
2. Assign an IP address to the computer
 - Set the Default Gateway and Subnet Mask of the computer to match the projector.
 - Set the IP address of the computer to match the first three numbers of the projector.
For example, if the projector IP address is 192.168.000.100, set the computer IP address to 192.168.000. xxx, where xxx is not 100.
3. Open a web browser and type the projector address in the address bar.
The web page redirects to the web control panel.

9.6 Using RS232 command by Telnet

How to use

This projector supports using RS232 commands through Telnet connection.

1. Set up direct connection between the projector and computer. See block Directly connect the projector to a computer, in [“Using the web control center”, page 62](#)
2. Disable the firewall on the computer.
3. Open the command dialogue on the computer. For Windows 7 operating system, select *Start > All Programs > Accessories > Command Prompt*.
4. Input the command “telnet ttt.xxx.yyy.zzz 3023”.
Replace “ttt.xxx.yyy.zzz” with the projector IP address.
5. Press **Enter** on the computer keyboard.

Specification for RS232 by Telnet

- Telnet: TCP
- Telnet port: 3023 (contact service team for more details)
- Telnet utility: Windows “TELNET.exe” (console mode).
- Disconnection for RS232-by-Telnet control normally: Close
- Below are the limitations for using Windows Telnet utility directly after TELNET connection is ready:
 - There is less than 50 bytes for successive network payload for Telnet-Control application.
 - There is less than 26 bytes for one complete RS232 command for Telnet-Control.
 - Minimum delay for next RS232 command must be more than 200 (ms).

9.7 Baud Rate

About baud rate

Set the baud rate for the serial port.

Serial Port In

Set the baud rate for Serial Port In. The available options are:

- 1200
- 2400
- 4800

- 9600
- 19200
- 38400
- 57600
- 115200 (default)

9.8 Reset

About reset

Reset all the communication settings to factory default values.

System menu

10

10.1	Language	66
10.2	Date and Time	66
10.3	On Screen Display	67
10.4	Logo Setup	67
10.5	Schedule	67
10.6	Standby Mode	70
10.7	Power Settings	70
10.8	Light Source Settings	70
10.9	Shutter	70
10.10	Security	71
10.11	Backlight	71
10.12	High Altitude	71
10.13	12V Trigger	72
10.14	User Data	72
10.15	Reset	72
10.16	Service	72

10.1 Language

About language

Select a language for the OSD menu.

The available languages are:

- English,
- Simplified Chinese,
- French,
- German,
- Italian,
- Japanese,
- Korean,
- Russian,
- Spanish,
- Portuguese,
- Indonesian,
- Dutch

10.2 Date and Time

About date and time

Set up the date and time for the projector.

Clock mode

Set the clock mode to Use NTP Server (network-based) or Manual.



If you set the Clock Mode to Use NTP Server, make sure the projector has access to the Internet.

Date

Set a date for the projector. The date format is in Year/Month/Date.

Time

Set the time for the projector.

Daylight Saving Time

Configure the daylight saving settings if required.

NTP Server

Select a NTP Server for the network clock mode.

Time Zone

Set a time zone for the network clock mode.

Update Interval

Set the date and time update interval.

Apply

Apply date and time modifications.

10.3 On Screen Display

About on screen display

Set up the on screen display menus.

Menu Location

Select the menu location from Top Left, Top Right, Center, Bottom Left, and Bottom Right.

Menu Transparency

Set the menu transparency level.

Menu Timer

Set the length of time the menu displays on the screen.

Show Message

Enable or disable the corner information messages, such as input source, IP address, and so on.

Background

Set a background color to display when no input signal is detected. The available options are Blue, Black, White, and Logo.

Reset

Reset the menu settings to default factory values.

10.4 Logo Setup

About logo setup

Set up the logo for the startup screen.

Change Logo

Change the logo for the startup screen. Apart from the Default logo, user can select also Captured Logo.

- **Default Logo:** The default startup screen.
- **Captured Logo:** The logo is saved via the Logo Capture function.
- **Save:** Save the captured logo.

Delete Logo

Delete the saved Captured Logo.

10.5 Schedule

About schedule

Schedule the project functions to operate automatically at the set time.

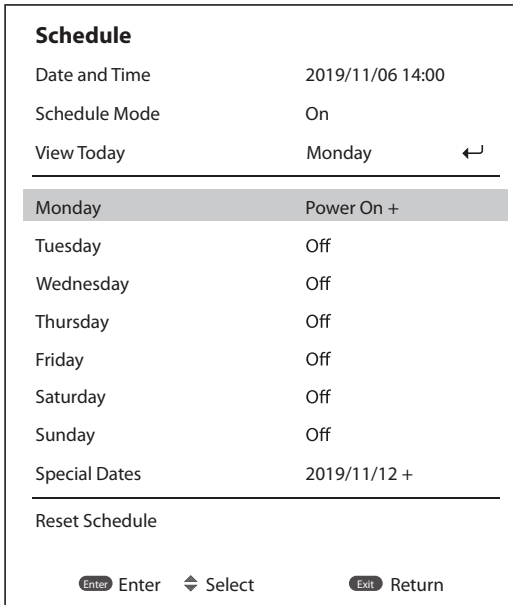

Image 10-1

Date and Time

Check or adjust the date and time for the projector.

Schedule Mode

Enable or disable the schedule function. If the projector is controlled via external devices or software, the Schedule Mode displays AP Mode, and the projector’s schedule functions are grayed out.

View Today

View the event list scheduled for today.

Monday to Sunday

Set up the schedule for days of a week. On the Schedule menu page, select a day and configure the schedule settings.

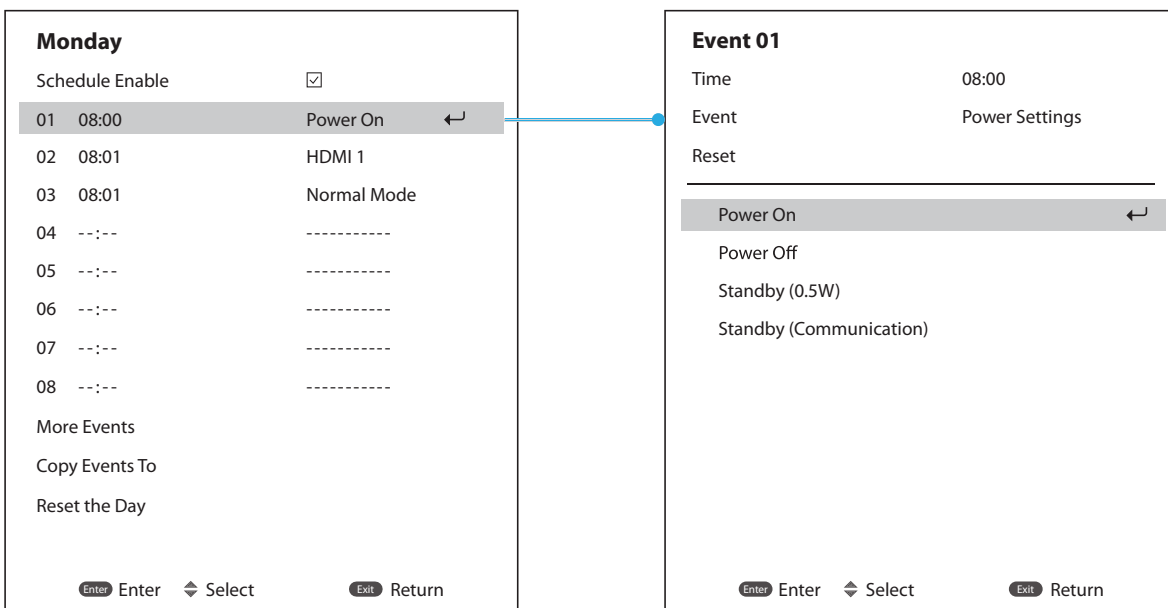

Image 10-2

- **Schedule Enable:** Enable or disable the schedule function for the selected day.

- **Event 01-08 / Event 09-16:** Select an event record number, and set up the schedule details.
 - **Time:** Set the time for the event.
 - **Function:** Set the function. The available functions are Power Settings, Input Source, Light Source Mode, and Shutter.
 - **Event:** Select a function for the event, which operates automatically at the set time.
 - **Reset:** Reset the event settings.
- **More Events / Previous Events (Event 01-16):** Display more event records, and select one to set up the schedule details.

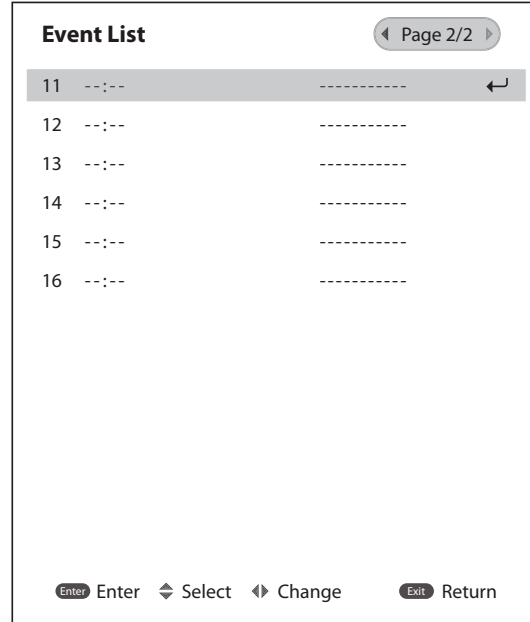
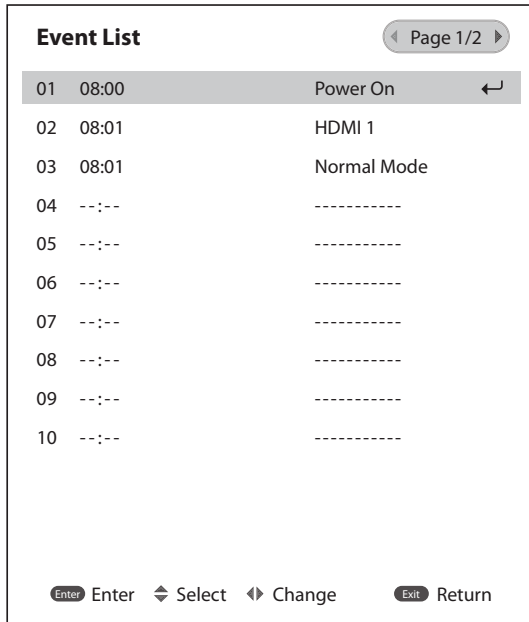

Image 10-3

- **Copy Events To:** Copy the events setup for the day to another day.

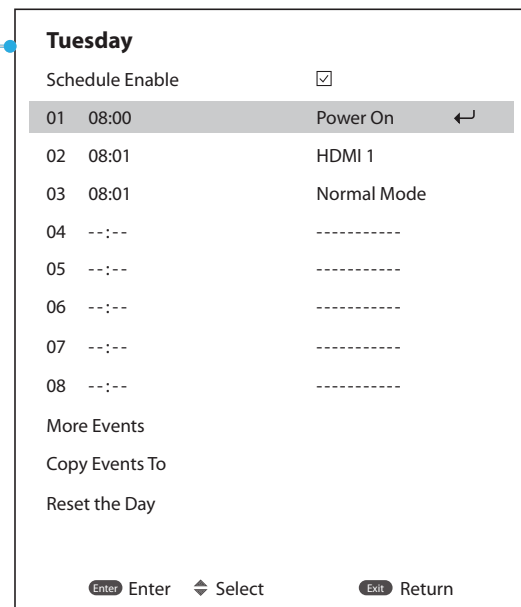
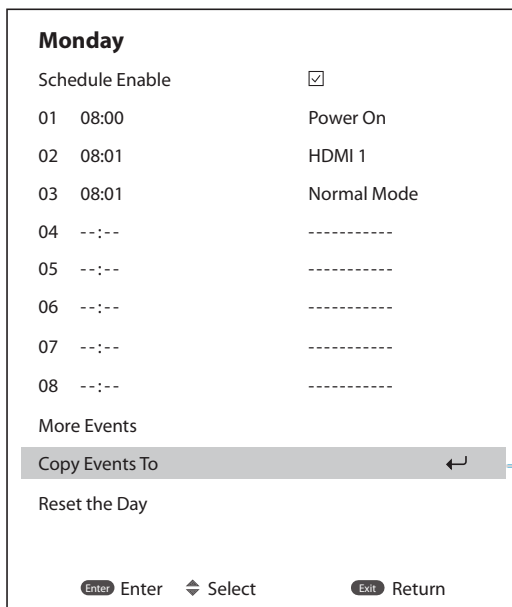

Image 10-4

- **Reset:** Reset the schedule settings for the day.

Reset

Reset all of the schedule settings.

10.6 Standby Mode

About standby mode

Setup the projector standby mode.

- **Standby Mode:** Minimum power consumption (0.5 Watt) which does not allow network controlling.
- **Network Standby Mode:** Low power consumption (< 2 Watt) which allows the LAN module to enter sleep mode and supports to be woken by Wake on LAN (WoL). When the LAN module is woken by WoL, the projector is ready to receive commands over the network.
- **Communication Mode:** More power consumption that allows controlling the projector over the network.

10.7 Power Settings

About power settings

Configure the projector's power settings. When going on or going to sleep.

Fast Power On

Turn on this function to have the projector automatically turning on when connected to HDMI input sources.

Auto Power Off

Set an interval timer for the projector to automatically turn off if no signal is detected within the specified time period.

Press the ◀ and ▶ buttons to increase or reduce time. The available time range is 0-180 minutes.

Sleep Timer

Set an interval timer for the projector to automatically turn off after operating for the specified amount of time. The available time range is 0-16 hours.

Reset

Reset the power settings to factory default values.

10.8 Light Source Settings

About light source settings

Set up the light source to control the projector brightness.

Light Source Mode

Select a light source mode depending on the installation requirements.

The available options are .

- Normal
- Eco Mode
- Custom Mode

10.9 Shutter

About the shutter

Set up the shutter behavior.

Fade-In

This function allows the fading in effect when turning off shutter. The time for the fading effect can be adjusted from 0.5s to 5s.

Fade-Out

This function allows the fading out effect when turning on shutter. The time for the fading effect can be adjusted from 0.5s to 5s.

Startup

Select the shutter behavior when turning on the projector.

10.10 Security

About security

Set up the projector security options.

Security

Enable to protect the projector with a password. If the user enters incorrect password three times, a message will pop up warning that the projector shuts down in 10 seconds.

Security Timer

Specify the length of time the projector can be used without the password. Once the timer counts to 0, the user must enter a password to use the projector. The timer restarts every time the projector is turned on.

Change Password

Change the password required to operate the projector.

10.11 Backlight

About backlight

Set up the projector backlight options for the keypad and power key.

Keypad

Enable or disable the keypad backlight.

Power Key

Enable or disable the backlight for the power key.

10.12 High Altitude

About high altitude

Check the option to increase the fan speed. To ensure the image quality and prevent damage to the projector, enable High Altitude mode in high temperature, high humidity, or high altitude environment.

10.13 12V Trigger

About 12V trigger

When enabled, the projector screen is automatically raised or lowered when the projector is turned on or off. This function only works when the projector is connected to an electrical projector screen.

10.14 User Data

About user data

User can save the projector settings as user data and reload the settings later.

- **Save All Settings:** Save all of the projector settings as user data. User can save up to 5 records.
- **Load All Settings:** Load the previously saved user data.

10.15 Reset

About reset

Reset the projector settings to factory default values.

- **Reset System Settings:** Reset the settings of the system menu to factory default values.
- **Reset All Settings:** Reset all of the projector settings.
- **Reset Selective:** Reset the settings of one of the main menus. User can choose from INSTALLATION, IMAGE, COMMUNICATION, and SYSTEM.

10.16 Service

About service

Input the service password to enter the service menu. In the Service menu, you can reset all settings to the factory defaults, set filter index, phosphor index, view error log, total projector hours, light source hours, and perform lens calibration.

Information menu

11

11.1 Projector information and status.....	74
--	----

11.1 Projector information and status

Overview

View the projector information about its status and settings. The projector information is read only.

- Projector
 - Model Name
 - Serial Number
 - Total Projector Hours
- System Status
 - Standby Mode
 - Light Source Mode
 - Light Source Hours
 - Temperature
- Communication
 - Projector ID
 - Remote Code
 - Ethernet
- Signal
 - Input Signal
 - Resolution
 - Signal Format
 - Pixel Clock
 - Horz Refresh
 - Vert Refresh
 - Color Space
 - Second Signal
 - Resolution
 - Signal Format
 - Pixel Clock
 - Horz Refresh
 - Vert Refresh
 - Color Space
- Firmware Version
 - Main Version
 - I-SCALER Version
 - F-MCU Version
 - A_MCU Version
 - K-MCU Version
 - LAN Version
 - Formater Version
 - FPGA0 Version
 - FPGA1 Version
 - XFPGA Version
 - HDBaseT Version

Troubleshooting

12

12.1	Projector Problems	76
12.2	LED indication chart.....	77



If you experience a problem with your projector, please refer to the following information. If a problem persists, please contact your local re-seller or service center.

12.1 Projector Problems

No image appears on-screen

- Check if all the cables and the AC power are correctly connected. For more details, refer to the installation manual.
- Check if the pins of the connectors are not crooked or broken.
- Check if the “Shutter (AV Mute)” function is disabled.

Partial, scrolling or incorrectly displayed image

- Press “Auto” on the remote control to detect input signal automatically.
- If you are using a PC, set the PC’s resolution lower or equal to WUXGA (1920 × 1200).
- If you are using a Notebook:
 - Set the resolution lower or equal to WUXGA (1920 × 1200).
 - Press the appropriate keys listed below for your notebook manufacturer to send signal out from notebook to projector. Example: [Fn]+[F4]

Acer	[Fn]+[F5]
Asus	[Fn]+[F8]
Dell	[Fn]+[F8]
Gateway	[Fn]+[F4]
BM/Lenovo	[Fn]+[F7]
HP/Compaq	[Fn]+[F4]
NEC	[Fn]+[F3]
Toshiba	[Fn]+[F5]
Mac Apple	System Preference > Display > Arrangement > Mirror display

- If you experience difficulty changing resolutions or your monitor freezes, restart all equipment including the projector.

Image is fuzzy and blurry

- Press the “Focus ▲” or “Focus ▼” button on the remote control or control panel to adjust the image focus until it is sharp and clear. To adjust focus from OSD menu, select “Installation > Lens > Focus”.
- Make sure the projection screen is in proper distance with the projector. For projection distances of each lens, see chapter *Lens specifications* in the installation manual.

Stretched when displaying 16:10 DVD videos

- Set appropriate aspect ratio for the projector by selecting “Installation > Aspect Ratio” from the OSD menu.
- Set the aspect ratio to 16:10 on the DVD player.

Image is too small or too large

- Adjust the image size by pressing the “Zoom ▲” or “Zoom ▼” button on the remote control or control panel, or selecting “Installation > Lens > Zoom” from the OSD menu.
- Adjust the distance between the projector and the screen.
- Adjust the aspect ratio by selecting “Installation > Aspect Ratio” from the OSD menu.

Image is not an even rectangle

- Perform keystone correction by pressing the “Keystone H” and “Keystone V” button on the remote control, or using “Installation > Geometry Correction > Basic Warp > Keystone Horizontal or Vertical” from the OSD menu.

Image is reversed

- To reverse the image, enable rear projection by selecting “Installation > Orientation > Direction > Rear Projection” from the OSD menu.

The projector stops responding to all controls

- If possible, turn off the projector, then unplug the power cord and wait at least 60 seconds before reconnecting power.

If the remote control does not work

- Check if the operating angle of the remote control is pointed within $\pm 30^\circ$ (front and back) to the remote receivers on the projector. Make sure there are any obstructions between the remote control and the projector.
- Check the remote batteries. Make sure batteries are inserted correctly. Replace the batteries if they are used up.
- Ensure you have set the correct IR code to the remote control. See “Remote Settings” in the chapter “Remote Setup”, page 60.

12.2 LED indication chart

Overview

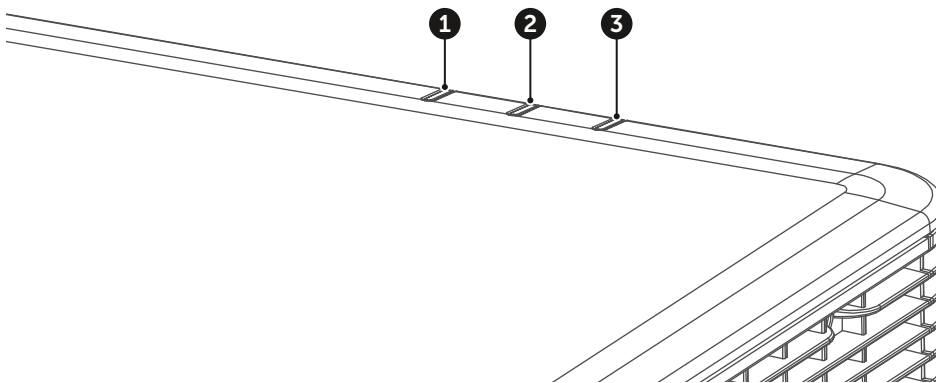

Image 12-1

- 1 AV Mute LED
- 2 Status LED
- 3 Light LED

Explanation

Message	Light LED			Status LED			AV Mute LED	
	Green	Orange	Red	Green	Orange	Red	Green	Orange
Standby State								
Power on (Warm up)					Flash- ing			
Power on & Laser diode on	Steady			Steady			Steady	
AV mute is off (Image is displayed)	Steady			Steady			Steady	
AV mute is on (Image is black)	Steady			Steady				Steady

Message	Light LED			Status LED			AV Mute LED	
	Green	Orange	Red	Green	Orange	Red	Green	Orange
Projector communication	Steady			Flash-ing			Steady	
Firmware upgrade				Flash-ing	Flash-ing			
Error (Over temperature)						Steady		
Error (Fan failure)						Flash-ing		



Power key of the keypad is in steady red light when the projector enters standby mode.

Specifications

A

A.1	Specifications for G62-W9	80
A.2	Specifications for G62-W11	81
A.3	Specifications for G62-W14	83
A.4	Dimensions of the G62	84
A.5	Ceiling mount	85
A.6	Compatibility modes	86
A.7	EDID table	90

A.1 Specifications for G62-W9

Overview

Projector type	Single chip DLP laser phosphor projector
Technology	0.67"
Resolution	1,920 x 1,200 (WUXGA)
Brightness	8,000 ANSI lumens 8,900 center lumens 9,500 ISO lumens
Contrast ratio	1,200:1 sequential; 6,000:1 dynamic; Extreme black: 750,000:1
Brightness uniformity	90%
Aspect ratio	16:10
Edge blending properties	horizontal and vertical edge blending
Lens type	G-lenses - 0.36:1 / 0.65-0.75:1 / 0.75-0.95:1 / 0.95-1.22:1 / 1.22-1.52:1 / 1.52-2.92:1 / 2.90-5.50:1
Optical lens shift	Vertical up to 100%, depending on lens Horizontal up to 30%, depending on lens Motorized zoom and focus Motorized lens shift
Maximum screen size	400"
Color correction	Yes
CLO (constant light output)	Yes
Light source	Laser phosphor
Light source lifetime	Up to 20,000hrs
Light source warranty	20.000hrs or 3 years, whatever comes first
Sealed DLP™ core	Yes
Orientation	360° rotation, no restrictions
3D	Active stereoscopic 3D
Image processing	Embedded warp & blend possible via Ptoolset
Optical dowser	laser dimming
DMX 512	N/A
Integrated web browser	Yes
Inputs	2x HDMI In (version 2.0) (with locking screw) / 1x DVI-D (only support digital signal) / 1x HDBaseT / 1x 3D SYNC In / 1x 3G-SDI
Input resolutions	Up to 4K UHD @60Hz Refresh rates: 24Hz to 60Hz for WUXGA and 4KUHD (4096 x 2160 : 3860 x 2160)
Software tools	Projector Toolset
Control	1x RS232, 3.5mm phone jack for wired remote
Network connection	10/100 Ethernet, RJ45
Output	1 x HDMI Out / 1 x 3D SYNC Out / 1 x DC 12V Out

Power requirements	100-240V / 50-60Hz
Power consumption	625W nominal, 750W maximum
BTU per hour	2,133 BTU/h nominal; 2,252 BTU/h maximum
Standby power	less than 0.5W
Noise level (typical at 25°C/ 77°F)	36dB(A) - 40dB(A) depending on the used mode
Operating temperature	0 - 40 °C (sea level)
Storage temperature	-10 to 60 °C
Operating humidity	10 - 85% RH, non-condensing
Storage humidity	5 - 90% RH, non-condensing
Dimensions (WxLxH)	without feet: 484 x 529 x 195 mm / 19.1 x 20.8 x 7.7 inch with feet: 484 x 529 x 206 mm / 19.1 x 20.8 x 8.1 inch
Weight	without lens: 17.4 kg / 38.4 lbs
Volume	50 dmm ³
Shipping dimensions (WxLxH)	596 x 628 x 395 mm / 23.5 x 24.7 x 15.6 inches
Shipping weight	22.6 kg
Standard accessories	Power cord, wireless remote control
Certifications	CE, FCC Class A, cTUVUS, CCC, EAC, KCC, RCM, BIS, BSMI
Warranty	Limited 3 years parts and labor

A.2 Specifications for G62-W11

Overview

Projector type	Single chip DLP laser phosphor projector
Technology	0.67"
Resolution	1,920 x 1,200 (WUXGA)
Brightness	9,500 ANSI lumens 10,600 center lumens 11,000 ISO lumens
Contrast ratio	1,200:1 sequential; 6,000:1 dynamic; Extreme black: 750,000:1
Brightness uniformity	90%
Aspect ratio	16:10
Edge blending properties	horizontal and vertical edge blending
Lens type	G-lenses - 0.36:1 / 0.65-0.75:1 / 0.75-0.95:1 / 0.95-1.22:1 / 1.22-1.52:1 / 1.52-2.92:1 / 2.90-5.50:1
Maximum screen size	400"
Optical lens shift	Vertical up to 100%, depending on lens Horizontal up to 30%, depending on lens Motorized zoom and focus Motorized lens shift

Color correction	Yes
CLO (constant light output)	Yes
Light source	Laser phosphor
Light source lifetime	Up to 20,000hrs
Light source warranty	20.000hrs or 3 years, whatever comes first
Sealed DLP™ core	Yes
Optical dowser	laser dimming
Orientation	360° rotation, no restrictions
DMX 512	N/A
3D	Active stereoscopic 3D
Image processing	Embedded warp & blend possible via Ptoolset
Integrated web browser	Yes
Inputs	2x HDMI In (version 2.0) (with locking screw) / 1x DVI-D (only support digital signal) / 1x HDBaseT / 1x 3D SYNC In / 1x 3G-SDI
Input resolutions	Up to 4K UHD @60Hz Refresh rates: 24Hz to 60Hz for WUXGA and 4KUHD (4096 x 2160 / 3860 x 2160)
Software tools	Projector Toolset
Control	IR, RS232, RJ45, 3.5mm phone jack for wired remote
Network connection	10/100 Ethernet, RJ45
Output	1 x HDMI Out / 1 x 3D SYNC Out / 1 x DC 12V Out
Power requirements	100-240V / 50-60Hz
Power consumption	810W nominal, 970W maximum
BTU per hour	2,747 BTU/h nominal; 2883 BTU/h maximum
Standby power	less than 0.5W
Noise level (typical at 25°C/ 77°F)	35dB(A) - 39dB(A) depending on the used mode
Operating temperature	0 - 40 °C (sea level)
Storage temperature	-10 to 60 °C
Operating humidity	10 - 85% RH, non-condensing
Storage humidity	5 - 90% RH, non-condensing
Dimensions (WxLxH)	without feet: 484 x 529 x 195 mm / 19.1 x 20.8 x 7.7 inch with feet: 484 x 529 x 206 mm / 19.1 x 20.8 x 8.1 inch
Weight	without lens: 22.7 kg / 50.1 lbs
Volume	50 dmm ³
Shipping dimensions (WxLxH)	596 x 628 x 395 mm / 23.5 x 24.7 x 15.6 inches
Shipping weight	28.9 kg

Standard accessories	Power cord, wireless remote control
Certifications	CE, FCC Class A, cTUVUS, CCC, EAC, KCC, RCM, BIS, BSMI
Warranty	Limited 3 years parts and labor

A.3 Specifications for G62-W14

Overview

Projector type	Single chip DLP laser phosphor projector
Technology	0.67"
Resolution	1,920 x 1,200 (WUXGA)
Brightness	11,500 ANSI lumens 12,800 center lumens 13,600 ISO lumens
Contrast ratio	1,200:1 sequential; 6,000:1 dynamic; Extreme black: 750,000:1
Brightness uniformity	90%
Aspect ratio	16:10
Edge blending properties	horizontal and vertical edge blending
Lens type	G-lenses - 0.36:1 / 0.65-0.75:1 / 0.75-0.95:1 / 0.95-1.22:1 / 1.22-1.52:1 / 1.52-2.92:1 / 2.90-5.50:1
Maximum screen size	400"
Optical lens shift	Vertical up to 100%, depending on lens Horizontal up to 30%, depending on lens Motorized zoom and focus Motorized lens shift
Color correction	Yes
CLO (constant light output)	Yes
Light source	Laser phosphor
Light source lifetime	Up to 20,000hrs
Light source warranty	20,000hrs or 3 years, whatever comes first
Sealed DLP™ core	Yes
Optical dowser	laser dimming
Orientation	360° rotation, no restrictions
DMX 512	N/A
3D	Active stereoscopic 3D
Image processing	Embedded warp & blend possible via Ptoolset
Integrated web browser	Yes
Inputs	2x HDMI In (version 2.0) (with locking screw) / 1x DVI-D (only support digital signal) / 1x HDBaseT / 1x 3D SYNC In / 1x 3G-SDI
Input resolutions	Up to 4K UHD @60Hz Refresh rates: 24Hz to 60Hz for WUXGA and 4KUHD (4096 x 2160 / 3860 x 2160)

Software tools	Projector Toolset
Control	IR, RS232, RJ45, 3.5mm phone jack for wired remote
Network connection	10/100 Ethernet, RJ45
Output	1 x HDMI Out / 1 x 3D SYNC Out / 1 x DC 12V Out
Power requirements	100-240V / 50-60Hz
Power consumption	1020W nominal, 1200W maximum
BTU per hour	4,002 BTU/h nominal; 4159 BTU/h maximum
Standby power	less than 0.5W
Noise level (typical at 25°C/ 77°F)	37dB(A) - 42dB(A) depending on the used mode
Operating temperature	0 - 40 °C (sea level)
Storage temperature	-10 to 60 °C
Operating humidity	10 - 85% RH, non-condensing
Storage humidity	5 - 90% RH, non-condensing
Dimensions (WxLxH)	without feet: 484 x 529 x 195 mm / 19.1 x 20.8 x 7.7 inch with feet: 484 x 529 x 206 mm / 19.1 x 20.8 x 8.1 inch
Weight	without lens: 22.7 kg / 50.1 lbs
Volume	50 dmm ³
Shipping dimensions (WxLxH)	596 x 628 x 395 mm / 23.5 x 24.7 x 15.6 inches
Shipping weight	28.9 kg
Standard accessories	Power cord, wireless remote control
Certifications	CE, FCC Class A, cTUVUS, CCC, EAC, KCC, RCM, BIS, BSMI
Warranty	Limited 3 years parts and labor

A.4 Dimensions of the G62



CAUTION: Avoid installing the projector near a heat source.

Front view

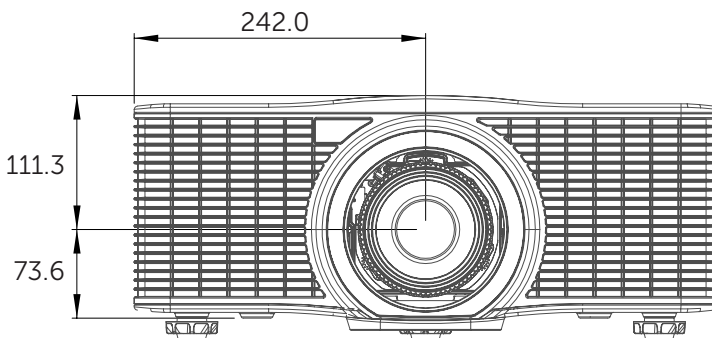

Image A-1 Dimensions given in millimeters.

Rear view

Image A-2 Dimensions given in millimeters.

Top view

Image A-3 Dimensions given in millimeters.

Left view

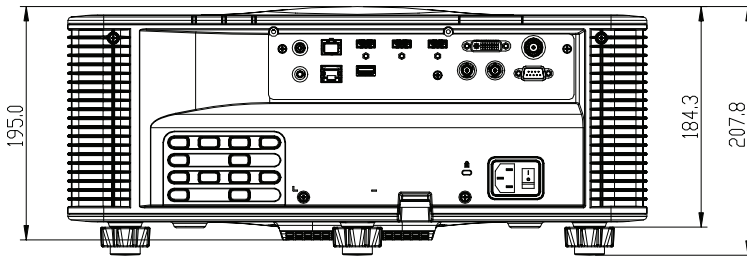
Image A-4 Dimensions given in millimeters.

A.5 Ceiling mount

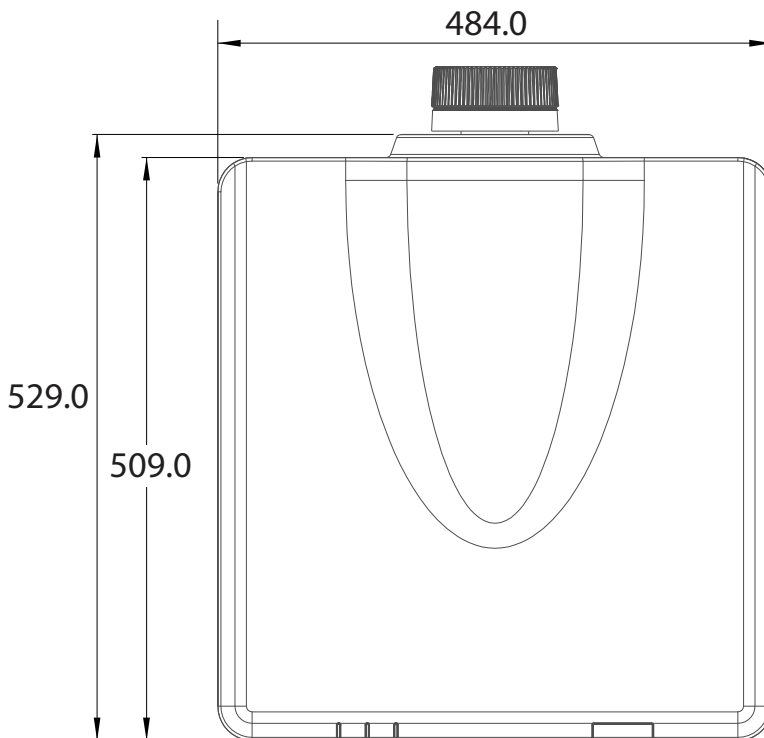
About ceiling mount

CAUTION: Be sure to use the correct screw size. Screw Length will vary depending on the thickness of the mounting plate.

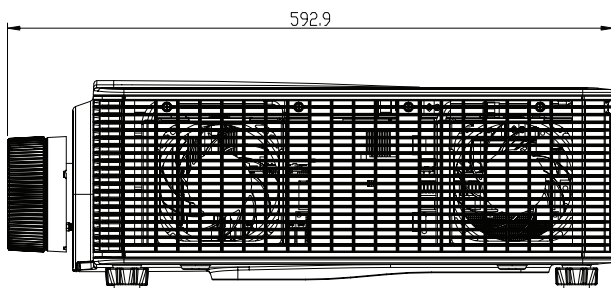

CAUTION: Be sure to keep at least 30 mm gap between the ceiling and the bottom of the projector.

Projector mounting holes

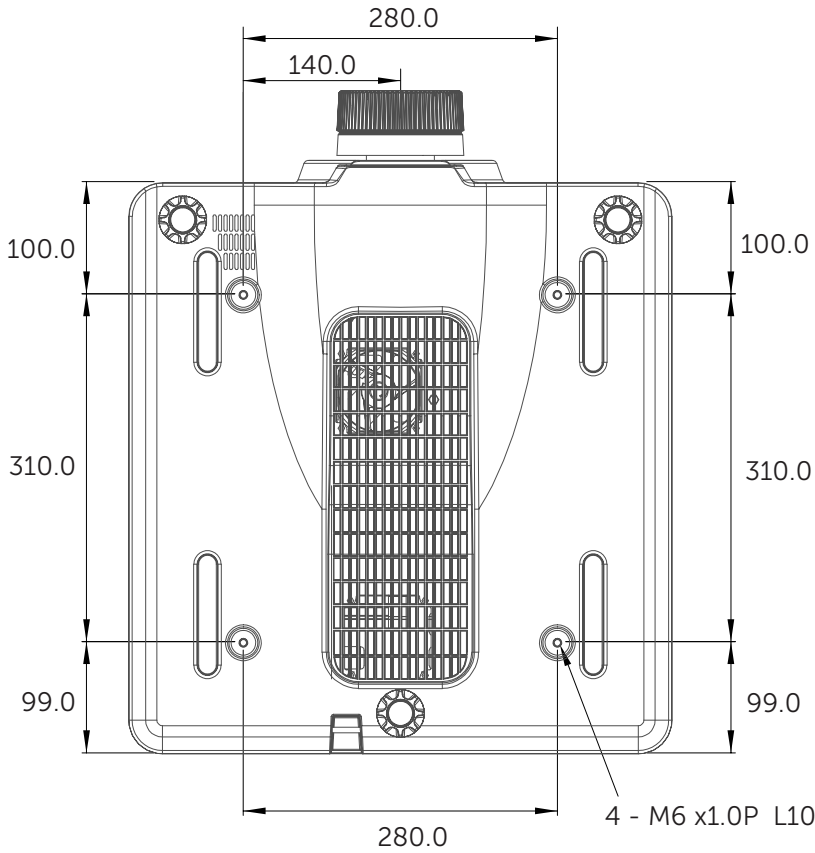

Image A-5 Dimensions given in millimeters.

A.6 Compatibility modes

Timing table

Signal type	Signal Format	Resolution	V sync (Hz)	HDMI1/2	DVI	HDBaseT	3G-SDI
PC	VGA	640x350	85	V	V	V	-
		640x400	85	V	V	V	-
		640x480	60	V	V	V	-
			72	V	V	V	-
			75	V	V	V	-
			85	V	V	V	-
	720x400	70	V	V	V	-	
	800x600	60	V	V	V	-	
	SVGA		72	V	V	V	-
			75	V	V	V	-
			85	V	V	V	-
			120	V	V	V	-
		832x624	75	V	V	V	-

Signal type	Signal Format	Resolution	V sync (Hz)	HDMI1/2	DVI	HDBaseT	3G-SDI
	XGA	848x480	60	V	V	V	-
		1024x768	60	V	V	V	-
			70	V	V	V	-
			75	V	V	V	-
			85	V	V	V	-
			120	V	-	V	-
	SXGA	1152x864	75	V	V	V	-
		1152x870	75	V	V	V	-
	WXGA	1280x768	60	V	V	V	-
			75	V	V	V	-
			85	V	V	V	-
	WXGA	1280x800	60	V	V	V	-
			75	V	V	V	-
			85	V	V	V	-
	SXGA	1280x960	60	V	V	V	-
			85	V	V	V	-
		1280x1024	60	V	V	V	-
			75	V	V	V	-
	WXGA	1360x768	60	V	V	V	-
		1366x768	60	V	V	V	-
	SXGA+	1400x1050	60	V	V	V	-
	WXGA+	1440x900	60	V	V	V	-
		1440x900	75	V	V	V	-
		1440x900	85	V	V	V	-
	WXGA++	1600x900	60	V	V	V	-
	UXGA	1600x1200	50	V	V	V	-
		1600x1200	60	V	V	V	-
WSXGA+	1680x1050	60	V	V	V	-	
WSXGA RB	1920X1200RB	60	V	V	V	-	
		50	V	V	V	-	
NTSC		NTSC (M, 4.43)	60	-	-	-	-
PAL		PAL (B,G,H,I)	50	-	-	-	-
		PAL (N)	50	-	-	-	-
		PAL (M)	60	-	-	-	-
SECAM		SECAM (M)	50	-	-	-	-
SDTV	480i	720x480	59,94	V	V	V	-
			60	V	V	V	-
	576i	720x576	50	V	V	V	-
EDTV	480p	720x480	50,94	V	V	V	-
			60	V	V	V	-
	576i	720x576	50	V	V	V	-
HDTV	1080i	1920x1080	50	V	V	V	-
			59.94	V	V	V	-

Signal type	Signal Format	Resolution	V sync (Hz)	HDMI1/2	DVI	HDBaseT	3G-SDI
	720p	1280x720	60	V	V	V	-
			50	V	V	V	-
			59,94	V	V	V	-
			60	V	V	V	-
			120	V	V	V	-
	1080p	1920x1080	23,98	V	V	V	-
			24	V	V	V	-
			25	V	V	V	-
			29,97	V	V	V	-
			30	V	V	V	-
			50	V	V	V	-
			59,94	V	V	V	-
			60	V	V	V	-
			120	V	V	V	-
			Mandatory 3D	Frame Packing 1080p	1920x1080	23,98	V
24	V	V				V	-
Frame Packing 720p	1280x720	50		V	V	V	-
		59,94		V	V	V	-
		60		V	V	V	-
Side by Side 1080i	1920x1080	50		V	V	V	-
		50,94		V	V	V	-
		60		V	V	V	-
Side by Side 1080p	1920x1080	23,98		V	V	V	-
		24		V	V	V	-
		59,9		V	V	V	-
		60		V	V	V	-
Top and Bottom 720p	1280x720	50		V	V	V	-
		59,94		V	V	V	-
		60		V	V	V	-
Top and Bottom 1080p	1920x1080	23,98		V	V	V	-
		24		V	V	V	-
		50,9		V	V	V	-
		60		V	V	V	-
Frame Sequential 3D	SVGA	800x600		120	V	V	V
	XGA	1024x768	120	V	V	V	-
	HDTV	1280x720	120	V	V	V	-
	1080p	1920x1080	120	V	V	V	-
			50	V	V	V	-
			60	V	V	V	-
	WUXG	1920x1200	60	V	V	V	-
SD-SDI	SDTV 480i	480i YcbCr422 10bit	59.94	-	-	-	V
	SDTV 576i	576i YcbCr422 10bit	50	-	-	-	V
HD-SDI	HDTV 720p	720p Ycb-Cr422 10bit	50	-	-	-	V
			59.94	-	-	-	V

Signal type	Signal Format	Resolution	V sync (Hz)	HDMI1/2	DVI	HDBaseT	3G-SDI
	HDTV 1080i	1080i Ycb-Cr422 10bit	60	-	-	-	V
			50	-	-	-	V
			59.94	-	-	-	V
			60	-	-	-	V
	HDTV 1080p	1080p Ycb-Cr422 10bit	23.98	-	-	-	V
			24	-	-	-	V
			25	-	-	-	V
			29.97	-	-	-	V
	HDTV 1080sF	1080sF Ycb-Cr422 10bit	30	-	-	-	V
			25	-	-	-	V
			29.97	-	-	-	V
	3GA-SDI	HDTV 1080p	1080p Ycb-Cr422 10bit	30	-	-	-
50				-	-	-	V
59.94				-	-	-	V
3GB-SDI	HDTV 1080p	1080p Ycb-Cr422 10bit With 352M Payload ID	60	-	-	-	V
			50	-	-	-	V
			59.94	-	-	-	V
4K	3840x2160	3840x2160	24.000	V	V	V	-
			25.000	V	V	V	-
			30.000	V	V	V	-
			50.000	V	V	-	-
			60.000	V	V	-	-
	4096x2160 SMPTE	4096x2160	24.000	V	V	V	-
			25.000	V	V	V	-
			30.000	V	V	V	-
			50.000	V	V	-	-
			60.000	V	V	-	-

PIP/PBP Compatibility

PIP/PBP Matrix	DVI-D	HDMI-1	HDMI-2	3G-SDI	HDBaseT
DVI-D	-	V	V	V	V
HDMI-1	V	-	V	V	V
HDMI-2	V	V	-	V	V
3G-SDI	V	V	V	-	V
HDBaseT	V	V	V	V	-



PIP/PBP does not support 3D input.

A.7 EDID table

DVI

Established timing	Standard timing	Detail timing
720x400@70Hz	1024x768 @120Hz	1920x1200@59Hz
720x400@88Hz	1280x800@75Hz	1920x1080@60Hz
640x480@60Hz	1280x1024@60Hz	640x480@60Hz
640x480 @67Hz	1360x765 @60Hz	720x480 @60Hz
640x480 @72Hz	800x600 @120Hz	1280x720 @60Hz
640x480 @75Hz	1400x1050 @60Hz	1920x1080i @60Hz
800x600 @56Hz	1600x1200 @60Hz	720x480i @60Hz
800x600 @60Hz	1680x1050 @60Hz	720x576 @50Hz
800x600 @72Hz		1280x720 @50Hz
800x600 @75Hz		1920x1080i @50Hz
832x624 @75Hz		720x576i @50Hz
1024x768 @60Hz		1920x1080 @50Hz
1024x768 @70Hz		1920x1080 @24Hz
1024x768 @75Hz		1440x480 @60Hz
1280x1024 @75Hz		1920x1080 @25Hz
1152x870@75Hz		

HDMI 1.4

Established timing	Standard timing	Detail timing
720x400 @70Hz	1024x768 @120Hz	1920x1200 @59Hz
720x400 @88Hz	1280x800 @75Hz	1920x1080 @60Hz
640x480 @60Hz	1280x1024 @60Hz	640x480 @60Hz
640x480 @67Hz	1360x765 @60Hz	720x480 @60Hz
640x480 @72Hz	800x600 @120Hz	1280x720 @60Hz
640x480 @75Hz	1400x1050 @60Hz	1920x1080i @60Hz
800x600 @56Hz	1600x1200 @60Hz	720x480i @60Hz
800x600 @60Hz	1680x1050 @60Hz	720x576 @50Hz
800x600 @72Hz		1280x720 @50Hz
800x600 @75Hz		1920x1080i @50Hz
832x624 @75Hz		720x576i @50Hz
1024x768 @60Hz		1920x1080 @50Hz
1024x768 @70Hz		1920x1080 @24Hz

Established timing	Standard timing	Detail timing
1024x768 @75Hz		1440x480 @60Hz
1280x1024 @75Hz		1920x1080 @25Hz
1152x870 @75Hz		1280x720 @120Hz
		1920x1080 @120Hz
		3840x2160 @24Hz
		3840x2160 @25Hz
		3840x2160 @30Hz
		4096x2160 @24Hz
		4096x2160 @25Hz
		4096x2160 @30Hz

HDMI 2.0

Established timing	Standard timing	Detail timing
720x400@70Hz	1024x768@120Hz	1920x1200@59Hz
720x400@88Hz	1280x800@75Hz	1920x1080@60Hz
640x480@60Hz	1280x1024@60Hz	640x480@60Hz
640x480@67Hz	1360x765@60Hz	720x480@60Hz
640x480@72Hz	800x600@120Hz	1280x1080i@60Hz
640x480@75Hz	1400x1050@60Hz	1920x1080i@60Hz
800x600@56Hz	1600x1200@60Hz	720x480i@60Hz
800x600@60Hz	1680x1050@60Hz	720x576@50Hz
800x600@72Hz		1280x720@50Hz
800x600@75Hz		1920x1080i@50Hz
832x624@75Hz		720x576i@50Hz
1024x768@60Hz		1920x1080@50Hz
1024x768@70Hz		1920x1080@24Hz
1024x768@75Hz		1440x480@60Hz
1280x1024@75Hz		1920x1080@25Hz
1152x870@75Hz		1280x720@120Hz
		1920x1080@120Hz
		3840x2160@24Hz
		3840x2160@25Hz
		3840x 2160@30Hz

Established timing

Standard timing

Detail timing

3840x2160@50Hz

3840x2160@60Hz

Regulatory information

B

B.1	Product compliance	94
B.2	China RoHS compliance	95
B.3	Taiwan RoHS compliance.....	96
B.4	Turkey RoHS compliance.....	97
B.5	Disposal information	97
B.6	Contact information.....	98
B.7	Download Product Manual	98

B.1 Product compliance

UK Compliance



This product is fit for use in the UK.

Authorised Representative: Barco UK Ltd

Address: Building 329, Doncastle Road
Bracknell RG12 8PE, Berkshire, United Kingdom

EurAsian Conformity (EAC)



This product complies with the Safety of Low-Voltage Equipment (LVE Technical Regulation 004/2011, CU TR 004/2011) and the Electromagnetic Compatibility of Technical Products (EMC Technical regulation, CU TR 020/2011)

Federal Communications Commission (FCC Statement)

This equipment has been tested and found to comply with the limits for a class A digital device, pursuant to Part 15 of the FCC rules. These limits are designed to provide reasonable protection against harmful interference when the equipment is operated in a commercial environment. This equipment generates, uses, and can radiate radio frequency energy and, if not installed and used in accordance with the instruction manual, may cause harmful interference to radio communications. Operation of this equipment in a residential area may cause harmful interference, in which case the user will be responsible for correcting any interference at his own expense

Changes or modifications not expressly approved by the party responsible for compliance could void the user's authority to operate the equipment

FCC responsible: Barco Inc.
3059 Premiere Parkway Suite 400
30097 Duluth GA, United States
Tel: +1 678 475 8000

EMC notices

EN55032/CISPR32 Class A MME (MultiMedia Equipment)

Warning : This equipment is compliant with Class A of CISPR 32. In a residential environment this equipment may cause radio interference.

GB/T 9254.1 A级ITE(信息技术设备)

警告: 在居住环境中, 运行此设备可能会造成无线电干扰。

BSMI Taiwan Class A statement:

警告: 為避免電磁干擾, 本產品不應安裝或使用於住宅環境。

KC Korea

기종별 사용자안내문

A급기기 (업무용방송통신기자재) 이 기기는 업무용 환경에서 사용할 목적으로 적합성평가를 받은 기기로서 가정용 환경에서 사용하는 경우 전파간섭의 우려가 있습니다.

Made in information

The made in country is indicated on the product ID label on the product itself.

Production date

The month and year of production is indicated on the product ID label on the product itself.

B.2 China RoHS compliance

中国大陆 RoHS (Information for China ROHS compliance)

根据中国大陆《电器电子产品有害物质限制使用管理办法》（也称为中国大陆RoHS），以下部分列出了Barco产品中可能包含的有毒和/或有害物质的名称和含量。中国大陆RoHS指令包含在中国信息产业部MCV标准：“电子信息产品中有毒物质的限量要求”中。

According to the “Management Methods for the Restriction of the Use of Hazardous Substances in Electrical and Electronic Products” (Also called RoHS of Chinese Mainland), the table below lists the names and contents of toxic and/or hazardous substances that Barco’s product may contain. The RoHS of Chinese Mainland is included in the MCV standard of the Ministry of Information Industry of China, in the section “Limit Requirements of toxic substances in Electronic Information Products”.

零件项目(名称) Component name	有毒有害物质或元素 Hazardous substances and elements					
	铅 (Pb)	汞 (Hg)	镉 (Cd)	六价铬 (Cr6+)	多溴联苯 (PBB)	多溴二苯醚 (PBDE)
外壳 Shell	X	O	X	O	O	O
主板 Motherboard	X	O	O	O	O	O
引擎模块 Engine module	X	O	O	O	O	O
雷射光源模组 Laser light source module	X	O	O	O	O	O
风扇 Fan	X	O	O	O	O	O
铁件 Iron frame	X	O	O	O	O	O
线材 Wire	X	O	X	O	O	O
遥控器 Remote control	X	O	O	O	O	O
包装 Package	O	O	O	O	O	O

本表格依据SJ/T 11364的规定编制

This table is prepared in accordance with the provisions of SJ/T 11364.

O: 表示该有毒有害物质在该部件所有均质材料中的含量均在 GB/T 26572 标准规定的限量要求以下。

O: Indicates that this toxic or hazardous substance contained in all of the homogeneous materials for this part is below the limit requirement in GB/T 26572.

X: 表示该有毒有害物质至少在该部件的某一均质材料中的含量超出 GB/T 26572 标准规定的限量要求。

X: Indicates that this toxic or hazardous substance contained in at least one of the homogeneous materials used for this part is above the limit requirement in GB/T 26572.

在中国大陆销售的相应电子信息产品（EIP）都必须遵照中国大陆《电子电气产品有害物质限制使用标识要求》标准贴上环保使用期限（EFUP）标签。Barco产品所采用的EFUP标签（请参阅实例，徽标内部的编号使用于指定产品）基于中国大陆的《电子信息产品环保使用期限通则》标准。



All Electronic Information Products (EIP) that are sold within Chinese Mainland must comply with the “Marking for the restriction of the use of hazardous substances in electrical and electronic product” of Chinese Mainland, marked with the Environmental Friendly Use Period (EFUP) logo. The number inside the EFUP logo that Barco uses (please refer to the photo) is based on the “General guidelines of environment-friendly use period of electronic information products” of Chinese Mainland.

B.3 Taiwan RoHS compliance

限用物質含有情況標示聲明書 (Declaration of the Presence Condition of the Restricted Substances Marking)

單元 Unit	限用物質及其化學符號 Restricted substances and its chemical symbols					
	鉛 Lead (Pb)	汞 Mercury (Hg)	鎘 Cadmium (Cd)	六價鉻 Hexavalent chromium (Cr6+)	多溴聯苯 Polybrominated biphenyls (PBB)	多溴二苯醚 Polybrominated diphenyl ethers (PBDE)
塑膠外殼 Plastic shell	—	○	○	○	○	○
電源供應器 Power supply	—	○	○	○	○	○
印刷電路板 Printed circuit board	—	○	○	○	○	○
絕緣墊片 Insulating gasket	○	○	○	○	○	○
光學鏡片 Optical lenses	—	○	○	○	○	○
雷射模組 Laser module	—	○	○	○	○	○
風扇模組 Fan module	—	○	○	○	○	○
鐵件 Iron frame	—	○	○	○	○	○
線材 wire (interlock switch/power cord)	—	○	—	○	○	○
喇叭 Speaker	—	○	○	○	○	○
馬達 Motor	—	○	○	○	○	○
自復式保險絲 Resettable fuse (polyswitch)	○	○	○	○	○	○

	限用物質及其化學符號 Restricted substances and its chemical symbols					
單元 Unit	鉛 Lead (Pb)	汞 Mercury (Hg)	鎘 Cadmium (Cd)	六價鉻 Hexavalent chromium (Cr6+)	多溴聯苯 Polybrominated biphenyls (PBB)	多溴二苯醚 Polybrominated diphenyl ethers (PBDE)
配件 (如:遙控器等) Accessories (remote control, etc.)	—	○	○	○	○	○
<p>備考1. “超出0.1 wt %” 及 “超出0.01 wt %” 係指限用物質之百分比含量超出百分比含量基準值。 Note 1: “Exceeding 0.1 wt %” and “exceeding 0.01 wt %” indicate that the percentage content of the restricted substance exceeds the reference percentage value of presence condition.</p> <p>備考2. “○” 係指該項限用物質之百分比含量未超出百分比含量基準值。 Note 2: “○” indicates that the percentage content of the restricted substance does not exceed the percentage of reference value of presence.</p> <p>備考3. “—” 係指該項限用物質為排除項目。 Note 3: The “—” indicates that the restricted substance corresponds to the exemption.</p>						

備註: 此RoHS表格適用於以下產品型號: G62-W9, G62-W11, G62-W14

Hint: This RoHS table is suitable for following models: G62-W9, G62-W11, G62-W14

B.4 Turkey RoHS compliance

Turkey RoHS compliance



Türkiye Cumhuriyeti: AEEE Yönetmeliğine Uygundur.
 [Republic of Turkey: In conformity with the WEEE Regulation]

B.5 Disposal information

Disposal Information



Waste Electrical and Electronic Equipment (WEEE)

This symbol on the product indicates that, under the European Directive 2012/19/EU governing waste from electrical and electronic equipment, this product must not be disposed of with other municipal waste. Please dispose of your waste equipment by handing it over to a designated collection point for the recycling of waste electrical and electronic equipment. To prevent possible harm to the environment or human health from uncontrolled waste disposal, please separate these items from other types of waste and recycle them responsibly to promote the sustainable reuse of material resources.

For more information about recycling of this product, please contact your local city office or your municipal waste disposal service. For details, please visit the Barco website at: <http://www.barco.com/AboutBarco/weee>

Disposal of batteries in the product



This product contains batteries covered by the Directive 2006/66/EC which must be collected and disposed of separately from municipal waste.

If the battery contains more than the specified values of lead (Pb), mercury (Hg) or cadmium (Cd), these chemical symbols will appear below the crossed-out wheeled bin symbol.

By participating in separate collection of batteries, you will help to ensure proper disposal and to prevent potential negative effects on the environment and human health.

B.6 Contact information

Barco contact information

Registered office address: President Kennedypark 35, 8500 Kortrijk, Belgium

Contact address: Beneluxpark 21, 8500 Kortrijk, Belgium

Importers contact information

To find your local importer, contact Barco directly or one of Barco's regional offices via the contact information given on Barco's web site, www.barco.com.

B.7 Download Product Manual

Download Product Manual

Product manuals and documentation are available online at www.barco.com/td.

Registration may be required; follow the instructions given on the website.

IMPORTANT! Read Installation Instructions before connecting equipment to the mains power supply.

Index

Numbers/Symbols

12V trigger 72

A

Advanced color 53
Advanced image 55
Apply to user 57
Aspect ratio 44

B

Backlight 71
Battery
 Disposal 98
Baud rate 63
Brightness 52

C

Ceiling mount
 Holes 85
Color mode 52
Communication 25
Communication menu 59
 Baud rate 63
 Control 61
 Network setup 60
 Projector ID 60
 Remote setup 60
 Reset 64
Compatibility modes 86
Contact address 98
Contact information 98
Contrast 52
Control 61
Control panel 26

D

Date 66
Dimensions 84
Disposal 97
 Battery 98
Download
 Product manual 98

E

Edge mask 46
EDIT table 90
Electrical shock 12
Enclosed projection 19
Environmental information
 Disposal information 97
 RoHS compliance
 China 95
 Taiwan 96
 Turkey 97
EurAsian Conformity (EAC) 94

F

Fire hazard 13
Freeze screen 50

G

Gamma 53
General considerations 16
 Safety 10
Geometry correction 46

H

Hazard Distance 17, 19
Hazardous Chemicals 15
HD
 Safety 11

High altitude 71
High Brightness precautions 17

I

ID 31
Image menu 51
 Advanced color 53
 Advanced image 55
 Apply to user 57
 Brightness 52
 Color mode 52
 Contrast 52
 Gamma 53
 Reset 57
 Saturation 52
 Save to user 57
 Sharpness 52
 Tint 52
 White balance 53
Importer 98
Info tri 20
Information menu 73
 Projector information 74
 Status 74
Input 25
Input-Output 26
Installation 41
 Aspect ratio 44
 Edge mask 46
 Freeze screen 50
 Geometry correction 46
 Lens 43
 Multi-projection 48
 Orientation 43
 Reset 50
 Scale 44
 Signal 44
 Test pattern 49
Instructions
 Safety 12

L

Language 66
Laser safety precautions
 Safety 10
LED Indication chart 77
Lens 43
Light source settings 70
Logo setup 67

M

Main unit 22
Multi-projection 48

N

Network setup 60
Notice on safety 10

O

On screen display 67
On/Off 35
Orientation 43
OSD 40
Overview 31

P

Personal injury 12
Power 35
Power Off 36
Power On 36
Power settings 70
Product compliance 94
Product overview 21
Projector Address 31
Projector damage 13
Projector ID 60
Projector problems 76

R

RCU 29
 Battery 30
Rear projection 19
Registered office 98
Regulatory 20
Regulatory information 93
Remote control
 Usage 32
Remote Control 29
Remote setup 60
Reset 50, 57, 64, 72

S

Safety 9
 Battery explosion 14
 General considerations 10
 Hazard Distance 17, 19
 Hazardous Chemicals 15
 HD 11
 Instructions 12
 Laser safety precautions 10
 Prevent electrical shock 12
 Prevent fire hazard 13
 Prevent personal injury 12
 Prevent projector damage 13
 Safety Data Sheet (SDS) 15
 Servicing 14
 User definition 11
Safety Data Sheet (SDS) 15
Safety labels 15
Saturation 52
Save to user 57
Scale 44
Schedule 67
Schedule menu
 12V trigger 72
 Backlight 71

- High altitude 71
- Light source settings 70
- Power settings 70
- Reset 72
- Service 72
- Shutter 70
- Standby mode 70
- User data 72
- Security
 - Schedule menu
 - Security 71
- Service 72
- Sharpness 52
- Shutter 70
- Signal 44
- Specifications 79
 - G62 W11 81
 - G62 W9 80
 - G62-W14 83
- Standby mode 70
- System
 - Logo setup 67
 - On screen display 67
- System menu 65
 - Language 66
 - Schedule 67
- System settings
 - Date 66
 - Time 66

T

- Telnet
 - RS232 command 63
- Test pattern 49
- Time 66
- Tint 52
- Troubleshooting 75
- Turkey RoHS 97

U

- UK Compliance 20, 94
- User controls 39
 - Communication menu 59
- User data 72
- User definition
 - Safety 11

W

- Web control center 62
- WEEE 20, 97–98
- White balance 53



R5914653 /05 | 2022-08-22

www.barco.com