

ELIMINATOR[®]

LIGHTING

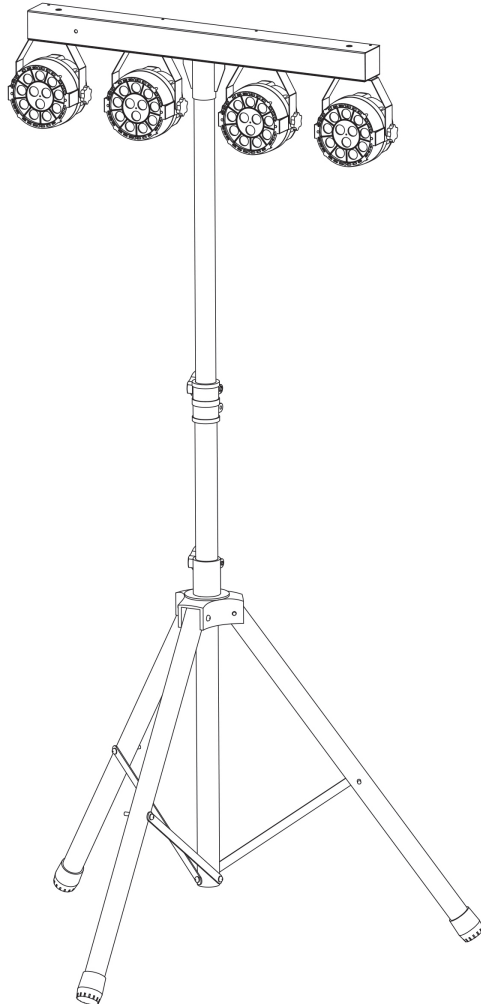

Mini Par Bar

User Manual

SKU#: MIN130
UPC#: 818651029925

©2021 ADJ Products, LLC all rights reserved. Information, specifications, diagrams, images, and instructions herein are subject to change without notice. Eliminator Lighting, ADJ Products, LLC logo and identifying product names and numbers herein are trademarks of ADJ Products, LLC. Copyright protection claimed includes all forms and matters of copyrightable materials and information now allowed by statutory or judicial law or hereinafter granted. Product names used in this document may be trademarks or registered trademarks of their respective companies and are hereby acknowledged. All non-ADJ Products, LLC brands and product names are trademarks or registered trademarks of their respective companies.

ADJ Products, LLC and all affiliated companies hereby disclaim any and all liabilities for property, equipment, building, and electrical damages, injuries to any persons, and direct or indirect economic loss associated with the use or reliance of any information contained within this document, and/or as a result of the improper, unsafe, insufficient and negligent assembly, installation, rigging, and operation of this product.

ADJ PRODUCTS LLC World Headquarters

6122 S. Eastern Ave. | Los Angeles, CA 90040 USA

Tel: 800-322-6337 | Fax: 323-582-2941 | www.adj.com | lsupport@adj.com

ADJ Supply Europe B.V.

Junostraat 2 | 6468 EW Kerkrade | Netherlands

Tel: +31 45 546 85 00 | Fax: +31 45 546 85 99 | www.americandj.eu | service@americandj.eu

Europe Energy Saving Notice

Energy Saving Matters (EuP 2009/125/EC)

Saving electric energy is a key to help protecting the environment. Please turn off all electrical products when they are not in use. To avoid power consumption in idle mode, disconnect all electrical equipment from power when not in use. Thank you!

DOCUMENT VERSION



Due to additional product features and/or enhancements, an updated version of this document may be available online.

Please check www.eliminatorlighting.com for the latest revision/update of this manual before beginning installation and/or programming.

Date	Document Version	Software Version	DMX Channels	Notes
07/28/2021	1.0	1.0	8 Channels	Initial Release
09/20/2021	1.5	N/C	N/C	Update Dimensions

CONTENTS

General Information	4
Limited Warranty (USA Only)	5
Safety Guidelines	6
Overview	8
DMX Set Up	10
Installation Instructions	12
System Menu	15
DMX Addressing	19
DMX Traits: Channel Functions & Values	20
Remote Control	24
Cleaning Maintenance	25
Specifications	27

GENERAL INFORMATION

INTRODUCTION

Please read and understand all instructions in this manual carefully and thoroughly before attempting to operate this product. These instructions contain important safety and use information.

UNPACKING: This product has been thoroughly tested and has been shipped in perfect condition. Carefully check the shipping carton for damage that may have occurred during shipping. If the carton appears to be damaged, carefully inspect your product for damage and be sure all accessories necessary to assemble the product have arrived intact. In the event that damage has been found or parts are missing, please contact our customer support team for further instructions. Please do not return this product to your dealer without first contacting customer support at the number listed below. Please do not discard the shipping carton in the trash. Please recycle whenever possible.

INCLUDED ITEMS

- Mini Par RGBW Lighting Fixture (x4)
- Mounting Bar (x1)
- Tripod Stand (x1)
- Power Cable (x1)
- Transportation Bag (x1)

CUSTOMER SUPPORT

Tel: (323) 213-4592 | Fax: (323) 582-2941

www.eliminatorlighting.com | support@eliminatorlighting.com

WARRANTY RETURNS

All returned service items, whether under warranty or not, must be freight pre-paid and accompanied by a return authorization (R.A.) number. The R.A. number must be clearly written on the outside of the return package. A brief description of the problem as well as the R.A. number must also be written down on a piece of paper and included in the shipping container. If the unit is under warranty, you must provide a copy of your proof of purchase invoice. Items returned without an R.A. number clearly marked on the outside of the package will be refused and returned at customer's expense. You may obtain an R.A. number by contacting customer support.

LIMITED WARRANTY (USA ONLY)

- A. Eliminator Lighting, an ADJ Products, LLC brand, hereby warrants, to the original purchaser, ADJ Products, LLC products to be free of manufacturing defects in material and workmanship for a prescribed period from the date of purchase (see specific warranty period on reverse). This warranty shall be valid only if the product is purchased within the United States of America, including possessions and territories. It is the owner's responsibility to establish the date and place of purchase by acceptable evidence, at the time service is sought.
- B. For warranty service, you must obtain a Return Authorization number (RA#) before sending back the product-please contact ADJ Products, LLC Service Department at 800-322-6337. Send the product only to the ADJ Products, LLC factory. All shipping charges must be pre-paid. If the requested repairs or service (including parts replacement) are within the terms of this warranty, ADJ Products, LLC will pay return shipping charges only to a designated point within the United States. If the entire instrument is sent, it must be shipped in its original package. No accessories should be shipped with the product. If any accessories are shipped with the product, ADJ Products, LLC shall have no liability whatsoever for loss of or damage to any such accessories, or for the safe return thereof.
- C. This warranty is void if the serial number has been altered or removed; if the product is modified in any manner which ADJ Products, LLC concludes, after inspection, affects the reliability of the product, if the product has been repaired or service by anyone other than ADJ Products, LLC factory unless prior written authorization was issued to purchaser by ADJ Products, LLC; if the product is damaged because not properly maintained as set forth in the instruction manual.
- D. This is not a service contract, and this warranty does not include maintenance, cleaning or periodic check up. During the period specified above, ADJ Products, LLC will replace defective parts at its expense with new or refurbished parts, and will absorb all expenses for warrant service and repair labor by reason of defects in material or workmanship. The sole responsibility of ADJ Products, LLC under this warranty shall be limited to the repair of the product, or replacement thereof, including parts, at the sole discretion of ADJ Products, LLC. All products covered by this warranty were manufactured after August 15, 2012, and bear identifying marks to that effect.
- E. ADJ Products, LLC reserves the right to make changes in design and/or improvements upon its products without any obligation to include these changes in any products theretofore manufactured.
- F. No warranty, whether expressed or implied, is given or made with respect to any accessory supplied with products described above. Except to the extent prohibited by applicable law, all implied warranties made by ADJ Products, LLC in connection with this product, including warranties of merchantability or fitness, are limited in duration to the warranty period set forth above. And no warranties, whether expressed or implied, including warranties of merchantability or fitness, shall apply to this product after said period has expired. The consumer's and/or Dealer's sole remedy shall be such repair or replacement as is expressly provided above; and under no circumstances shall ADJ Products, LLC be liable for any loss or damage, direct or consequential, arising out of the use of, or inability to use, this product.
- G. This warranty is the only written warranty applicable to ADJ Products, LLC Products and supersedes all prior warranties and written descriptions of warranty terms and conditions heretofore published.

LIMITED WARRANTY PERIODS

- **All Eliminator Lighting products (except laser diodes) = 1-year (365 days) Limited Warranty** (Such as: Special Effect Lighting, Intelligent Lighting, UV lighting, Strobes, Fog Machines, Bubble Machines, Mirror Balls, Par Cans, Trussing, Lighting Stands etc. excluding LED and lamps)
- **Laser Products = 1 Year (365 Days) Limited Warranty** (excludes laser diodes which have 6 month limited warranty)
- **Batteries = 180 Day Limited Warranty** (excluding batteries which have a 180 day limited warranty)

SAFETY GUIDELINES

To guarantee a smooth operation, it is important to follow all instructions and guidelines in this manual. ADJ Products, LLC is not responsible for injury and/or damages resulting from the misuse of this fixture due to the disregard of the information printed in this manual. Only qualified and/or certified personnel should perform installation of this fixture and only the original rigging parts included with this fixture should be used for installation. Any modifications to the fixture and/or the included mounting hardware will void the original manufactures warranty and increase the risk of damage and/or personal injury.



PROTECTION CLASS 1 - FIXTURE MUST BE PROPERLY GROUNDED



THERE ARE NO USER SERVICEABLE PARTS INSIDE THIS UNIT. DO NOT ATTEMPT ANY REPAIRS YOURSELF; DOING SO WILL VOID YOUR MANUFACTURES WARRANTY. DAMAGES RESULTING FROM MODIFICATIONS TO THIS FIXTURE AND/OR THE DISREGARD OF SAFETY INSTRUCTIONS AND GUIDELINES IN THIS MANUAL VOID THE MANUFACTURES WARRANTY AND ARE NOT SUBJECT TO ANY WARRANTY CLAIMS AND/OR REPAIRS.



**DO NOT PLUG FIXTURE INTO A DIMMER PACK!
NEVER OPEN THIS FIXTURE WHILE IN USE!
UNPLUG POWER BEFORE SERVICING FIXTURE!
NEVER TOUCH FIXTURE DURING OPERATION AS IT MAY BE HOT!
KEEP FLAMMABLE MATERIALS AWAY FROM FIXTURE!**



**INDOOR / DRY LOCATIONS USE ONLY!
DO NOT EXPOSE DEVICES TO RAIN AND/OR MOISTURE!**

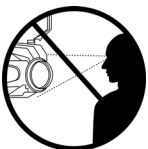

NEVER LOOK DIRECTLY INTO THE LIGHT SOURCE! RETINA INJURY RISK - MAY INDUCE BLINDNESS! SENSITIVE PERSONS MAY SUFFER AN EPILEPTIC SHOCK!

SAFETY GUIDELINES

This unit may “pop” the fuse if the maximum allotted load of 3 amps is reached.

- **To reduce the risk of electrical shock or fire, do not expose this unit rain or moisture.**
- **Do not spill water or other liquids into or on to your unit.**
- **Do not attempt to remove or break off the ground prong from the electrical cord. This prong is used to reduce the risk of electrical shock and fire in case of an internal short.**
- **Do not attempt to operate this unit if the power cord has been frayed or broken.**
- **Disconnect from main power before making any type of connection.**
- **Do not remove the cover under any conditions. There are no user serviceable parts inside.**
- **Always be sure to mount this unit in an area that will allow proper ventilation. Allow about 6” (15cm) between this device and a wall.**
- **Do not attempt to operate this unit if it has been damaged in any way.**
- **This unit is intended for indoor use only. Use of this product outdoors voids all warranties.**
- **During long periods of non-use, disconnect the unit’s main power.**
- **Always mount this unit in safe and stable matter.**
- **Power cords should be routed so they are not likely to be walked on, pinched by items placed upon or against them.**
- **Cleaning - The fixture should be cleaned only as recommended by the manufacturer. See the Maintenance Guidelines section of this manual for cleaning details.**
- **Heat - The appliance should be situated away from heat sources such as radiators, heat registers, stoves, or other appliances (including amplifiers) that produce heat.**
- **The fixture should be serviced by qualified service personnel when:**
 - A. The power-supply cord or the plug has been damaged.**
 - B. Objects have fallen, or liquid has been spilled into, the unit.**
 - C. The unit has been exposed to rain or water.**
 - D. The unit does not appear to operate normally or exhibits a marked change in performance.**

OVERVIEW

MOUNTING BAR AND LIGHTING FIXTURES

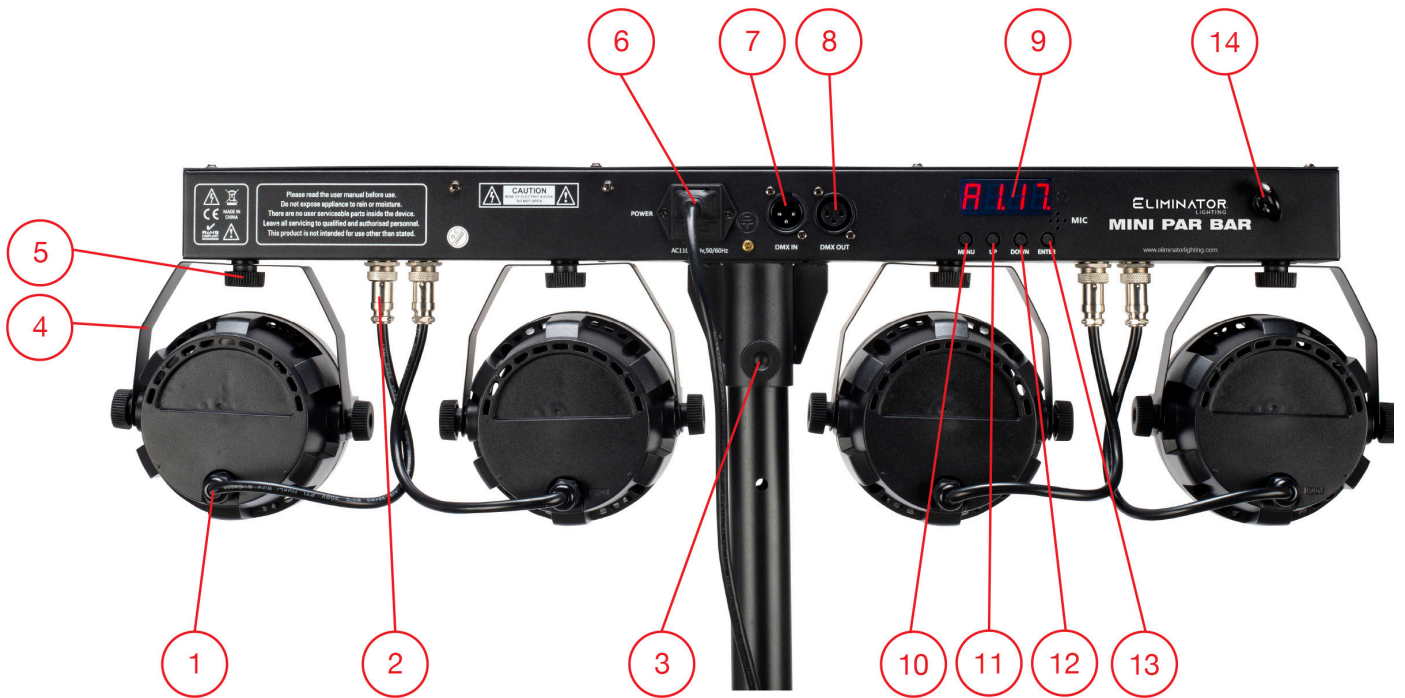

1. Fixture Power/Data Cable
2. Fixture Cable Connection Port (x4)
3. Pole Mount Socket and Thumbscrew
4. Fixture Mounting Yoke
5. Fixture Mounting Thumbscrew
6. Bar Power Connector w/ Fuse
7. DMX In Port
8. DMX Out Port
9. Display Screen
10. Menu Button
11. Up Button
12. Down Button
13. Enter Button
14. Safety Cable Loop

OVERVIEW

TRIPOD STAND



- 15. Height Adjustment Knob
- 16. Leg Adjustment Knob
- 17. Collapsible Legs (x3)

DMX SETUP

DMX-512: DMX is short for Digital Multiplex. This is a universal protocol used as a form of communication between intelligent fixtures and controllers. A DMX controller sends DMX data instructions from the controller to the fixture. DMX data is sent as serial data that travels from fixture to fixture via the DATA “IN” and DATA “OUT” XLR terminals located on all DMX fixtures (most controllers only have a DATA “OUT” terminal).

DMX Linking: DMX is a language allowing all makes and models of different manufacturers to be linked together and operate from a single controller, as long as all fixtures and the controller are DMX compliant. To ensure proper DMX data transmission, when using several DMX fixtures try to use the shortest cable path possible. The order in which fixtures are connected in a DMX line does not influence the DMX addressing. For example, a fixture assigned a DMX address of 1 may be placed anywhere in a DMX line: at the beginning, at the end, or anywhere in the middle. When a fixture is assigned a DMX address of 1, the DMX controller knows to send DATA assigned to address 1 to that unit, no matter where it is located in the DMX chain.

Data Cable (DMX Cable) Requirements (For DMX Operation): This device can be controlled via DMX-512 protocol. The DMX address is set using the display screen on the back of the device. Your unit and your DMX controller require a standard 3-pin XLR connector for data input and data output (Figure 1). We recommend Accu-Cable DMX cables. If you are making your own cables, be sure to use standard 110-120 Ohm shielded cable (This cable may be purchased at almost all pro lighting stores). Your cables should be made with a male XLR connector on one end and a female XLR connector on the other. Also remember that DMX cable must be daisy chained and cannot be split.



DMX SETUP

Notice: Be sure to follow figures two and three when making your own cables. Do not use the ground lug on the XLR connector. Do not connect the cable's shield conductor to the ground lug or allow the shield conductor to come into contact with the XLR cable's outer casing. Grounding the shield could cause a short circuit and erratic behavior.

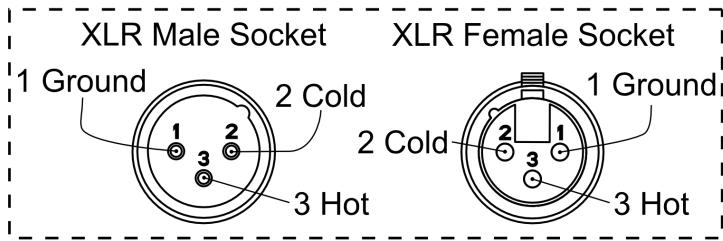
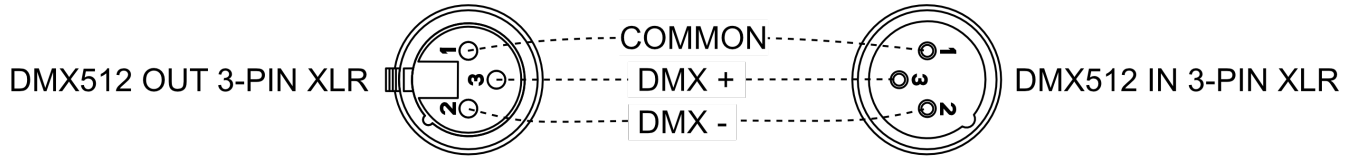

XLR Pin Configuration
Pin 1 = Ground
Pin 2 = Data Compliment (negative)
Pin 3 = Data True (positive)

Special Note: Line Termination. When longer runs of cable are used, you may need to use a terminator on the last unit to avoid erratic behavior. A terminator is a 110-120 ohm 1/4 watt resistor which is connected between pins 2 and 3 of a male XLR connector (DATA+ and DATA-). This unit is inserted in the female XLR connector of the last unit in your daisy chain to terminate the line. Using a cable terminator will decrease the chances of erratic behavior.

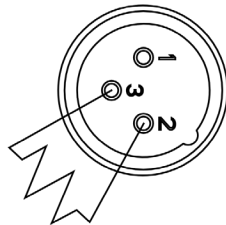

A DMX512 terminator reduces signal errors, avoiding most signal reflection interference. Connect PIN 2 (DMX-) and PIN 3 (DMX+) of the last fixture in series with a 120 Ohm, 1/4 W Resistor to terminate the DMX512.

INSTALLATION INSTRUCTIONS



FLAMMABLE MATERIAL WARNING

Keep devices at least 5.0 feet (1.5m) away from flammable materials and/or pyrotechnics.



ELECTRICAL CONNECTIONS

A qualified electrician should be used for all electrical connections and/or installations.



DO NOT INSTALL THE DEVICE IF YOU ARE NOT QUALIFIED TO DO SO!

OVERHEAD RIGGING REQUIRES EXTENSIVE EXPERIENCE, INCLUDING CALCULATING WORKING LOAD LIMITS, KNOWLEDGE OF INSTALLATION MATERIAL BEING USED, AND PERIODIC SAFETY INSPECTION OF ALL INSTALLATION MATERIALS. IF YOU LACK THESE QUALIFICATIONS, DO NOT ATTEMPT THE INSTALLATION YOURSELF. IMPROPER INSTALLATION CAN RESULT IN BODILY INJURY.

BEFORE RIGGING/MOUNTING DEVICES TO ANY METAL TRUSS/STRUCTURE OR CEILING, A PROFESSIONAL EQUIPMENT INSTALLER MUST BE CONSULTED TO DETERMINE WHETHER THE METAL TRUSS/STRUCTURE OR CEILING IS PROPERLY CERTIFIED TO SAFELY HOLD THE COMBINED WEIGHT OF THE LIGHT FIXTURE, CLAMPS, CABLES, AND ACCESSORIES.

BEFORE MOUNTING DEVICES TO ANY SURFACE OR STRUCTURE, MAKE SURE THE SURFACE OR STRUCTURE CAN HOLD A MINIMUM POINT LOAD OF 10 TIMES THE WEIGHT OF THE DEVICES.

MAKE SURE SCREWS AND/OR ANCHOR BOLTS (NOT INCLUDED) FIT INTO MOUNTING HOLES!

FOR ADDED PROTECTION, MOUNT DEVICES OUTSIDE WALKING PATHS, SEATING AREAS, OR AREAS WHERE UNAUTHORIZED PERSONNEL CAN REACH THE DEVICES.

SECURE FIXTURE WITH A SECONDARY SAFETY ATTACHMENT, SUCH AS AN APPROPRIATE SAFETY CABLE. (NOT INCLUDED)

NEVER STAND DIRECTLY BELOW THE DEVICES WHEN MOUNTING, REMOVING OR SERVICING.

OPERATING TEMPERATURE RANGE IS -4°F TO 104°F (-20°C TO 40°C). DO NOT OPERATE THE DEVICE WHEN AMBIENT TEMPERATURE FALLS OUTSIDE THIS RANGE!

DEVICES MUST ALL BE INSTALLED FOLLOWING ALL LOCAL, NATIONAL, AND COUNTRY COMMERCIAL ELECTRICAL AND CONSTRUCTION CODES AND REGULATIONS.

INSTALLATION INSTRUCTIONS

CLAMP INSTALLATION

The mounting bar features two mounting clamp attachment points, with one mounting point located at each end of the top face. Please note that **both mounting points** must be used when installing the device in a hanging configuration. The device also features a safety cable loop located on the rear face, near the display screen (see the illustration below). When mounting the fixture to a truss or any other suspended or overhead installation, be sure to secure appropriately rated clamps (**not included**) to the clamp attachment points and attach a separate **SAFETY CABLE** of the appropriate safety rating to the safety cable rigging point.

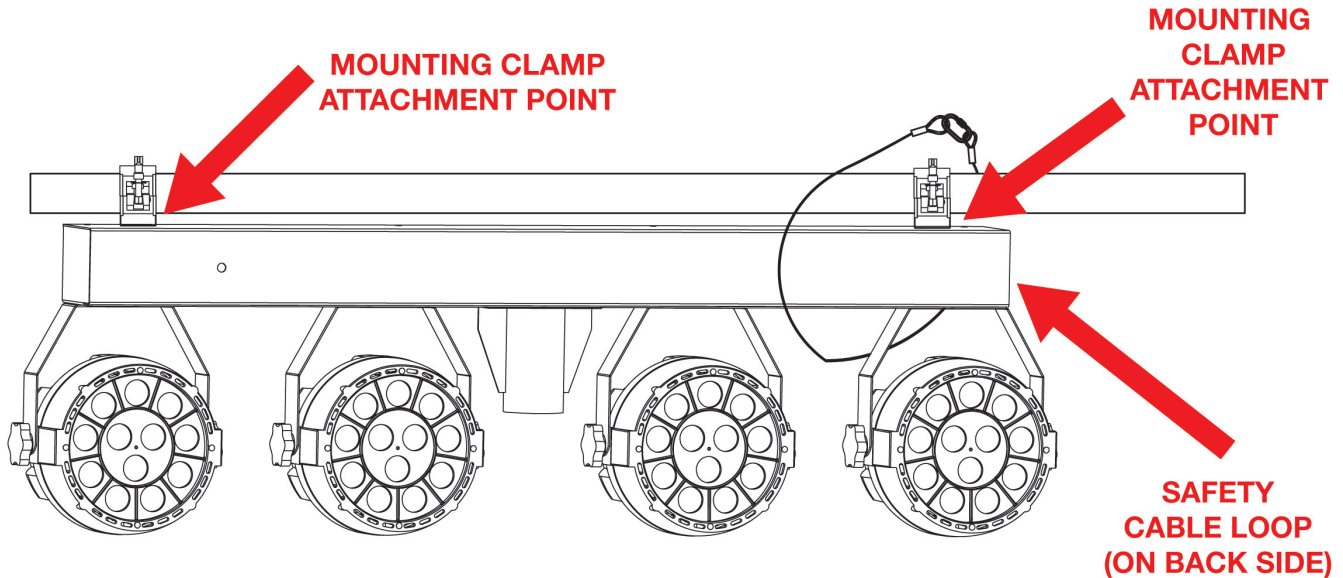

SAFETY CABLE: ALWAYS ATTACH A SAFETY CABLE WHENEVER INSTALLING THIS FIXTURE IN A SUSPENDED ENVIRONMENT TO ENSURE THAT THE FIXTURE WILL NOT FALL IF THE CLAMP FAILS.

RIGGING

Overhead rigging requires extensive experience, including but not limited to: calculating working load limits, understanding the installation material being used, and periodic safety inspection of all installation material and the fixture itself. If you lack these qualifications, do not attempt to perform the installation yourself. Improper installation can result in bodily injury.

INSTALLATION INSTRUCTIONS

TRIPOD STAND MOUNT

The bar features a pole mount socket that allows the device to be mounted securely atop the tripod stand. Lock the tripod legs in a stable position, making sure that the leg adjustment knob is tightened securely. Then loosen the height adjustment knob, lower the tripod stand to its lowest position, and re-tighten the height adjustment knob. Fit the bar's pole mount socket over the top of the tripod stand's vertical pole, then tighten the fixture mounting thumbscrew on the bar to secure it in place. Adjust the tripod stand to the desired height using the height adjustment knob.

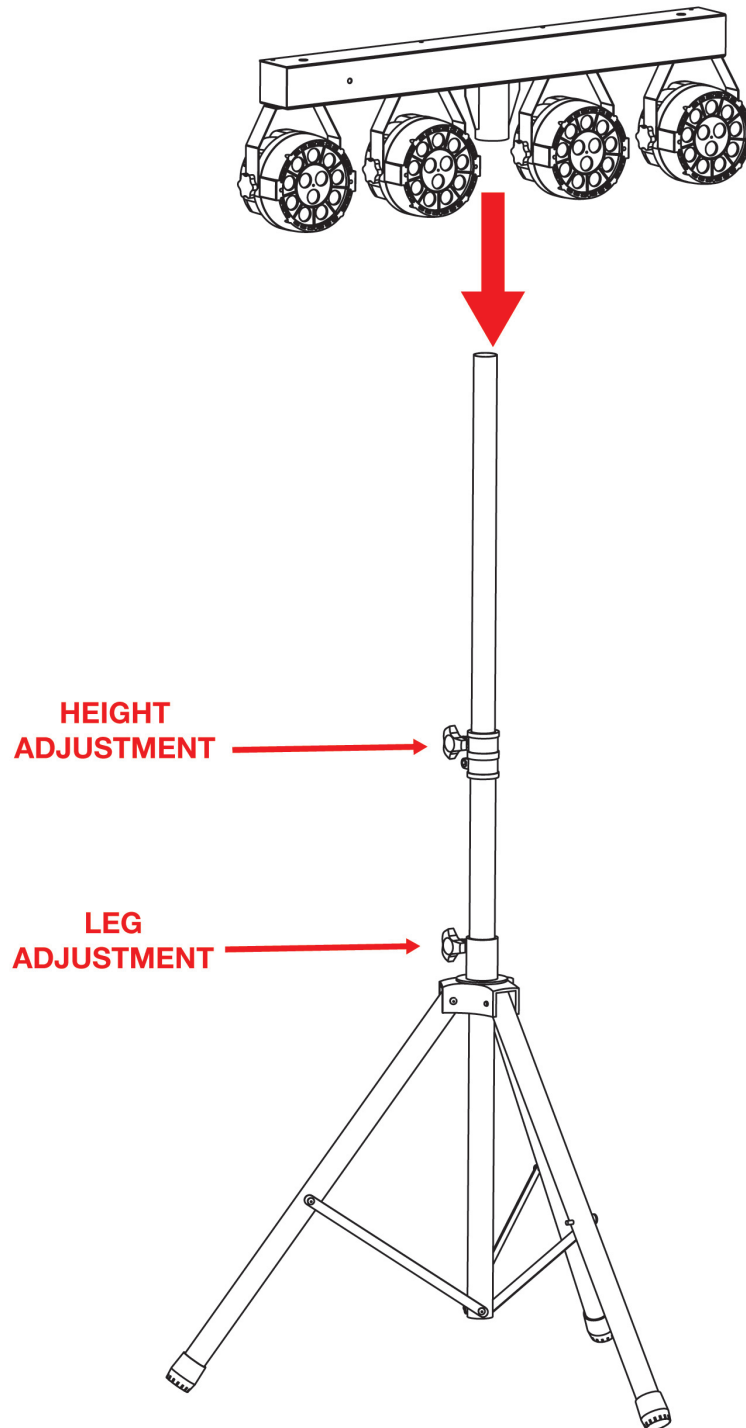

SYSTEM MENU

CONTROL PANEL

The device includes an easy to navigate system menu that can be accessed via a set of control buttons located on the back face of the device below the digital display.

MENU: Press to cycle through main menu options.

UP/DOWN: Press to adjust the setting of the displayed main menu option.

ENTER: Press to confirm the setting adjustment.

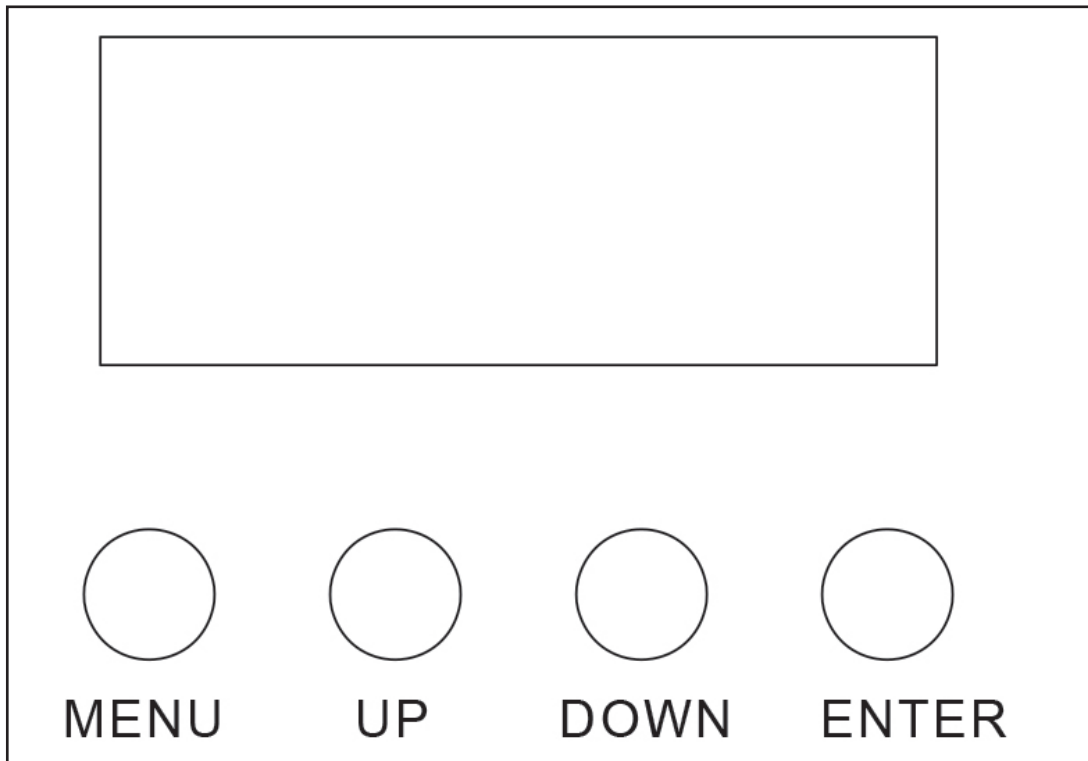

SYSTEM MENU

MENU	FUNCTION	DESCRIPTION
dxxx	d001 - d512	DMX address setting
iPxx	iP01 - iP64	IP mode setting
A1.xx	A1.01	Static color mode, R+G+B+W
	A1.02	Static color mode, R
	A1.03	Static color mode, G
	A1.04	Static color mode, B
	A1.05	Static color mode, R+G
	A1.06	Static color mode, G+B
	A1.07	Static color mode, R+B
	A1.08	Static color mode, W
	A1.09	Static color mode, R+G
	A1.10	Static color mode, R+B
	A1.11	Static color mode, R+W
	A1.12	Static color mode, G+B
	A1.13	Static color mode, G+W
	A1.14	Static color mode, B+W
	A1.15	Static color mode, R+G+W
	A1.16	Static color mode, R+B+W
	A1.17	Static color mode, G+B+W
	A1.18	Static color mode, R+G+B
A2.xx (flash)	A2.01 - A2.32	Strobe speed, slow to fast
A3.xx	A3.01	Fade mode, single color fade mode
	A3.02	Fade mode, red
	A3.03	Fade mode, green
	A3.04	Fade mode, blue
	A3.05	Fade mode, yellow
	A3.06	Fade mode, cyan
	A3.07	Fade mode, purple
	A3.08	Fade mode, white
	A3.09	Fade mode, R+G
	A3.10	Fade mode, R+B
	A3.11	Fade mode, R+W
<i>CONTINUED ON NEXT PAGE</i>		

SYSTEM MENU

MENU	FUNCTION	DESCRIPTION
A3.xx (continued)	A3.12	Fade mode, G+B
	A3.13	Fade mode, G+W
	A3.14	Fade mode, B+W
	A3.15	Fade mode, R+G+W
	A3.16	Fade mode, R+B+W
	A3.17	Fade mode, G+B+W
	A3.18	Fade mode, R+G+B
	A3.19	Fade mode, R+G+B+W
A3.xx (flash)	A3.01 - A3.32	Fade mode speed, slow to fast
A4.xx	A4.01	Sound active mode, all color change
	A4.02	Sound active mode, all on
	A4.03	Sound active mode, R
	A4.04	Sound active mode, G
	A4.05	Sound active mode, B
	A4.06	Sound active mode, R+G
	A4.07	Sound active mode, G+B
	A4.08	Sound active mode, R+B
	A4.09	Sound active mode, W
	A4.10	Sound active mode, R+G+B
	A4.11	Sound active mode, R+B
	A4.12	Sound active mode, R+W
	A4.13	Sound active mode, G+B
	A4.14	Sound active mode, G+W
	A4.15	Sound active mode, R+W
	A4.16	Sound active mode, R+G+W
	A4.17	Sound active mode, R+B+W
	A4.18	Sound active mode, G+B+W
A4.19	Sound active mode, R+B+G	
A4.xx (flash)	A4.01 - A4.04	Sound active sensitivity, low to high

CONTINUED ON NEXT PAGE

SYSTEM MENU

MENU	FUNCTION	DESCRIPTION
A5.xx	A5.01	Strobe mode, color change
	A5.02	Strobe mode, GBW on + R strobe
	A5.03	Strobe mode, RBW on + G strobe
	A5.04	Strobe mode, RGW on + B strobe
	A5.05	Strobe mode, BW on + RG strobe
	A5.06	Strobe mode, RW on + GB strobe
	A5.07	Strobe mode, GW on + RB strobe
	A5.08	Strobe mode, RGB on + W strobe
	A5.09	Strobe mode, BW on + RG strobe
	A5.10	Strobe mode, GW on + RB strobe
	A5.11	Strobe mode, GB on + RW strobe
	A5.12	Strobe mode, RW on + GB strobe
	A5.13	Strobe mode, RB on + GW strobe
	A5.14	Strobe mode, RG on + BW strobe
	A5.15	Strobe mode, B on + RGW strobe
	A5.16	Strobe mode, G on + RBW strobe
	A5.17	Strobe mode, R on + GBW strobe
	A5.18	Strobe mode, W on + RGB strobe
	A5.19	Strobe mode, R+G+B+W strobe
A5.xx (flash)	A5.01 - A5.32	Strobe speed, slow to fast
rxxx	r000 - r255	Red color dimming, 0% - 100%
Gxxx	G000 - G255	Green color dimming, 0% - 100%
bxxx	b000 - b255	Blue color dimming, 0% - 100%
uxxx	u000 - u255	White color dimming, 0% - 100%

DMX ADDRESSING

All fixtures should be given a DMX starting address when operating with a DMX controller, in order to ensure that the correct fixture responds to the correct control signal. This digital starting address is the channel number from which the fixture starts to “listen” to the digital control signal sent out from the DMX controller. This starting DMX address is assigned by setting the correct DMX address on the digital control display on the fixture.

You can set the same starting address for all fixtures or a group of fixtures, or set different addresses for each individual fixture. Setting all fixtures to the same DMX address will cause all fixtures to react in the same way. In this case, please note that changing the settings of one channel will affect all the fixtures simultaneously.

If you set each fixture to a different DMX address, each unit will start to “listen” to the channel number you have set, based on the quantity of DMX channels of each fixture. That means changing the settings of one channel will only affect the selected fixture.

For example, these fixtures feature 8 DMX channels, so you should set the starting DMX address of the first unit to 1, the second unit to 9 (1 + 8), the third unit to 17 (1 + 8 + 8), and so on. (See the chart below for more details.)

Channel Mode	Unit 1 Addr	Unit 2 Addr	Unit 3 Addr	Unit 4 Addr
8-Ch	1	9	17	25

INTERNAL PATCH (IP MODE) FUNCTION

This device also features an Internal Patch function, which displays on the screen as “IP Mode.” With this function, the user simply needs to select the desired IP Mode on each lighting fixture, and the fixture will automatically determine its own DMX address.

For example, if 4 units have been linked together, ordinarily the user would need to calculate the starting address of the first unit as 1, the second unit as 9, the third unit at 17, and the fourth unit at 25, as shown in the table above. However, with IP Mode, the user would simply set the first device to “IP01,” the second device to “IP02,” the third device to “IP03,” and the fourth device to “IP04.” Each unit would then automatically set itself to the correct DMX address, removing the need to manually calculate each starting address.

To use this function, the user simply needs to navigate to the “IP.xx” option in the main menu, then select the IP mode value, in ascending order of lowest to highest DMX address. Selectable values range from 01 to 64. See the **System Menu** section of this manual for details on navigating to this sub-menu.

Channel Mode	Unit 1 Addr	Unit 2 Addr	Unit 3 Addr	Unit 4 Addr
IP MODE	IP.01	IP.02	IP.03	IP.04

DMX TRAITS: CHANNEL FUNCTIONS & VALUES (8 DMX Channels)

Eliminator Mini Par Bar - DMX Traits		
Software Version 1.0		
CHANNEL	DMX VALUE	DESCRIPTION
1		Mode
	000 - 010	No function
	011 - 050	Macro A1: Macro color
	051 - 100	Macro A2: 18 color change
	101 - 150	Macro A3: Fade mode
	151 - 200	Macro A4: Sound active mode
	201 - 255	Macro A5: Strobe mode
2 (CH1 = 011 - 050)		Color Macro
	000 - 039	RGBW, all on
	040 - 049	Red
	050 - 059	Green
	060 - 069	Blue
	070 - 079	Yellow (RG)
	080 - 089	Cyan (GB)
	090 - 099	Purple (RB)
	100 - 109	White
	110 - 119	Orange (RG)
	120 - 129	Pink (RB)
	130 - 139	RW
	140 - 149	GB
	150 - 159	GW
	160 - 169	BW
	170 - 179	RGW
	180 - 189	RBW
	190 - 199	GBW
	200 - 209	RGB
210 - 255	RGBW (all on)	
<i>CONTINUED ON NEXT PAGE</i>		

DMX TRAITS: CHANNEL FUNCTIONS & VALUES (8 DMX Channels)

Eliminator Mini Par Bar - DMX Traits		
Software Version 1.0		
CHANNEL	DMX VALUE	DESCRIPTION
2 (CH1 = 101 - 150)		Fade
	000 - 039	All color fade
	040 - 049	Red color fade
	050 - 059	Green color fade
	060 - 069	Blue color fade
	070 - 079	Yellow color fade
	080 - 089	Cyan color fade
	090 - 099	Purple color fade
	100 - 109	White color fade
	110 - 119	Red + green
	120 - 129	Red + blue
	130 - 139	Red + white
	140 - 149	Green + blue
	150 - 159	Green + white
	160 - 169	Blue + white
	170 - 179	Red + green + white
	180 - 189	Red + blue + white
	190 - 199	Green + blue + white
	200 - 209	Red + green + blue
	210 - 255	Red + green + blue + white
2 (CH1 = 151 - 200)		Sound Active
	000 - 039	All color change
	040 - 049	All on
	050 - 059	Red color strobe
	060 - 069	Green color strobe
	070 - 079	Blue color strobe
	080 - 089	Yellow color strobe
	090 - 099	Cyan color strobe
	100 - 109	Purple color strobe
	110 - 119	White color strobe
	120 - 129	Orange color strobe
CONTINUED ON NEXT PAGE		

DMX TRAITS: CHANNEL FUNCTIONS & VALUES (8 DMX Channels)

Eliminator Mini Par Bar - DMX Traits		
Software Version 1.0		
CHANNEL	DMX VALUE	DESCRIPTION
2 (CH1 = 151 - 200) (continued)		Sound Active (continued)
	130 - 139	Pink color strobe
	140 - 149	Red + white color strobe
	150 - 159	Dark green color strobe
	160 - 169	Green + white
	170 - 179	Blue + white
	180 - 189	Red + green + white
	190 - 199	Red + blue + white
	200 - 209	Green + blue + white
	210 - 255	Red + green + blue
2 (CH1 = 201 - 255)		Strobe Mode
	000 - 039	Color change
	040 - 049	GBW on + R strobe
	050 - 059	RBW on + G strobe
	060 - 069	RGW on + B strobe
	070 - 079	BW on + RG strobe
	080 - 089	RW on + GB strobe
	090 - 099	GW on + RB strobe
	100 - 109	RGB on + W strobe
	110 - 119	BW on + RG strobe
	120 - 129	GW on + RB strobe
	130 - 139	GB on + RW strobe
	140 - 149	RW on + GB strobe
	150 - 159	RB on + GW strobe
	160 - 169	RG on + BW strobe
	170 - 179	B on + RGW strobe
	180 - 189	G on + RBW strobe
	190 - 199	R on + GBW strobe
200 - 209	W on + RGB strobe	
210 - 255	RGBW strobe	
<i>CONTINUED ON NEXT PAGE</i>		

DMX TRAITS: CHANNEL FUNCTIONS & VALUES (8 DMX Channels)

Eliminator Mini Par Bar - DMX Traits		
Software Version 1.0		
CHANNEL	DMX VALUE	DESCRIPTION
3	000 - 255	Adjustable Speed , slow to fast
4	000 - 255	Master Dimming , 0% - 100%
5	000 - 255	Red color , 0% - 100%
6	000 - 255	Green color , 0% - 100%
7	000 - 255	Blue color , 0% - 100%
8	000 - 255	White color , 0% - 100%

REMOTE CONTROL

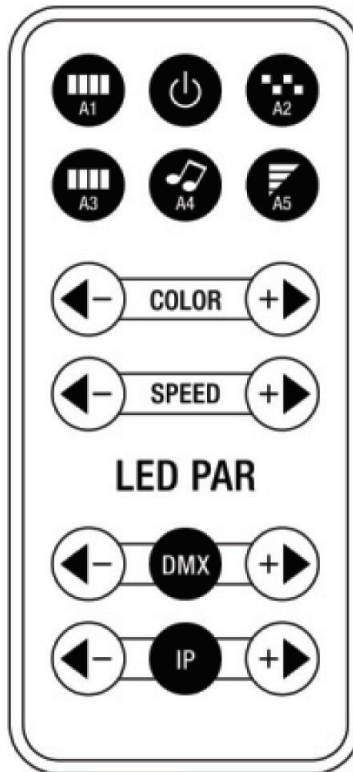

BUTTON	FUNCTION
A1	All Lights On
Power	Turn Device On/Off
A2	Color Jump Change
A3	Color Gradual Change
A4	Sound Active Mode
A5	Strobe Mode
Color +/-	Color Adjustment
Speed +/-	Speed Adjustment
DMX +/-	DMX Channel Select
IP +/-	Running Effect Select

CLEANING AND MAINTENANCE



DISCONNECT POWER BEFORE PERFORMING ANY CLEANING OR MAINTENANCE!

CLEANING

Frequent cleaning is recommended to ensure proper function, optimized light output, and an extended life. The frequency of cleaning depends on the environment in which the device operates: damp, smoky, or particularly dirty environments can cause greater accumulation of dirt on the fixture housing and/or light fixture optics. Clean the external surface and the front lens of the device periodically with a soft cloth to avoid dirt/debris accumulation

NEVER use alcohol, solvents, or ammonia-based cleaners.

MAINTENANCE

Regular inspections are recommended to ensure proper function and extended life. There are no user serviceable parts inside these devices; please refer all other service issues to Eliminator Lighting. Should you need any spare parts, please order genuine parts from Eliminator Lighting.

Please refer to the following points during routine inspections:

- A detailed review should be performed by an approved electrical engineer every three months, to make sure the circuit contacts are in good condition in order to prevent overheating.
- Be sure all screws and fasteners are securely tightened at all times. Loose screws may fall out during normal operation, resulting in damage or injury as larger parts could fall.
- Check for any deformations on the unit. Deformations could allow for dust to enter into the device, or cause the device to fall and seriously injure a person(s).
- Electric power supply cables must not show any damage, material fatigue, or sediments.

FUSE REPLACEMENT

The mounting bar features a replaceable fuse housed in a fuse clip below the Power Input on the back side of the device. To access the fuse, slide the fuse clip out of the device, then remove the fuse.

BE CAREFUL NOT TO DAMAGE THE FUSE CLIP, THE POWER INPUT, OR THE PRONGS. Replace only with a fuse of the same rating.

CLEANING AND MAINTENANCE

FUSE REPLACEMENT

The mounting bar features a replaceable fuse housed in a fuse clip below the Power Input on the back side of the device.

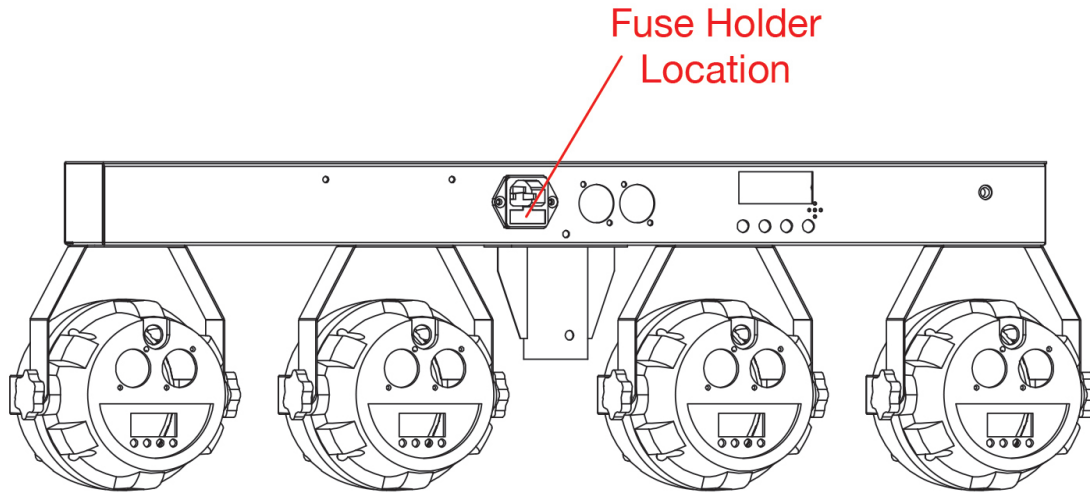

To access the fuse, first slide the fuse clip out of the device, then remove the fuse. **BE CAREFUL NOT TO DAMAGE THE FUSE CLIP, THE POWER INPUT, OR THE PRONGS.** Replace only with a fuse of the same rating.

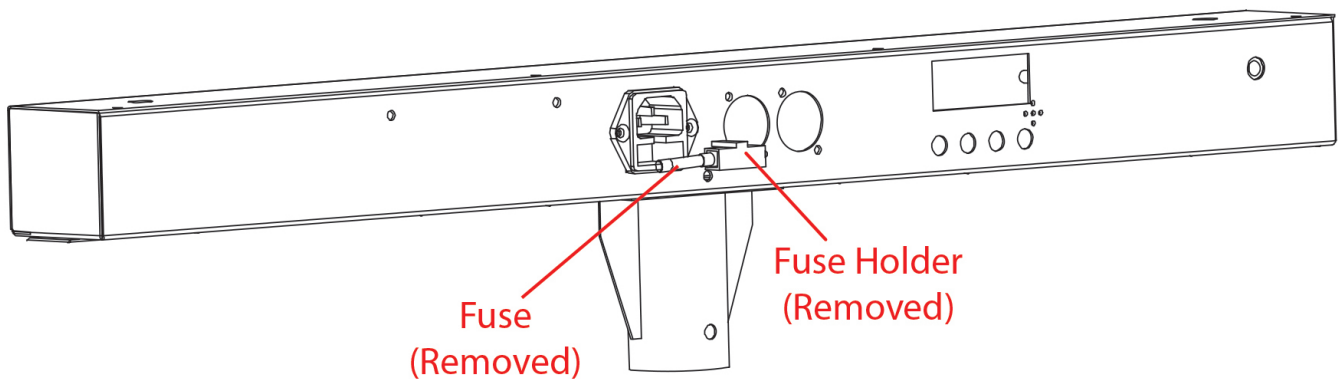

SPECIFICATIONS

- Light source: 4 fixtures with 12x 1-Watt RGBW (3 red, 3 green, 3 blue, 3 white) LEDs each
- Great for Stage Lighting, Bands, Night Clubs & Mobile Entertainers
- May be used with supplied tripod, mounted on truss or used on the ground
- Emits less heat on performers on stage as opposed to conventional stage lighting
- 25-degree beam angle
- 4-button LED display menu control system
- 4 control modes: Sound active, DMX, Auto or linking Primary/Secondary
- 8 DMX channels
- 3-pin DMX In/Out
- With Wired Digital Communication Network
- Max power: 80W
- Multi-voltage operation: AC 100V-240V 50/60Hz (IEC Input)
- Stand Height: 47.25" / 1200mm (minimum); 76.375" / 1940mm (maximum)
- Bar Dimensions (note dimension drawing for dimension orientation):
28.7in.(730mm) x 8.1in. (205mm) x 3.5in. (89mm)
- Tripod Stand Dimensions:
Tripod stand footprint (fully open): 33.9in. (860mm) x 29.9in (760mm)
Height (fully extended without bar attached): 74.4in. (1890mm)
Height (fully extended with bar attached): 76.4in. (1900mm)
- Dimensions (in carry bag): 1030x150x395mm
- Weight of the bar with lights: 6 lbs.
- Weight of the bar with lights and stand: 12.8 lbs.

IR Wireless Control features:

- Power On/Off button
- All On
- Quick color change
- Slow color change
- Strobe
- Color adjustment
- Chase speed adjustment
- DMX channel selection

DIMENSIONAL DRAWING

LIGHT FIXTURE AND PAR BAR

LIGHT FIXTURE

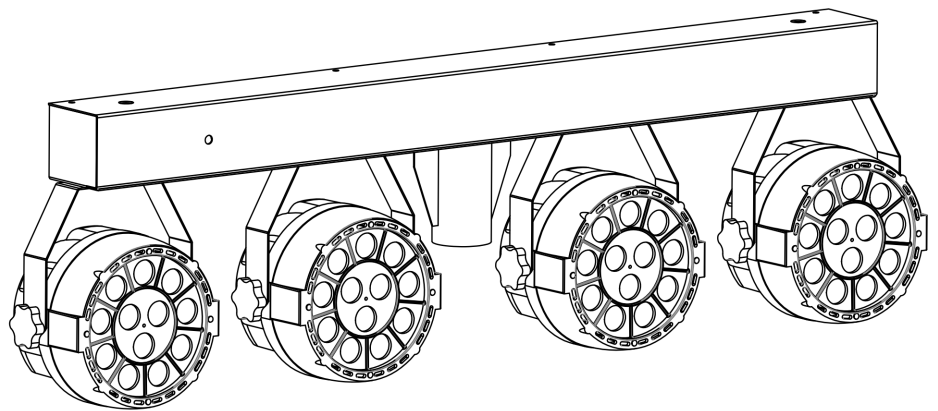
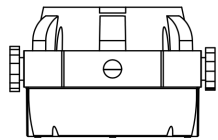
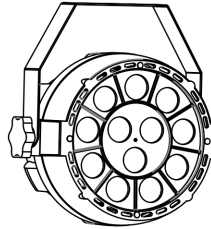
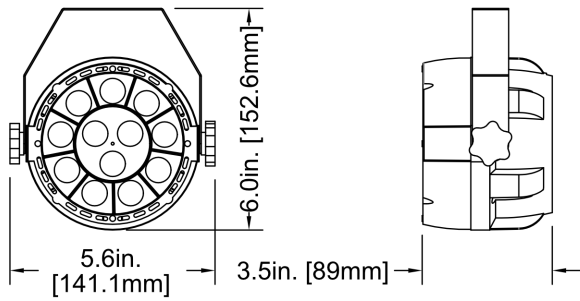

LIGHT FIXTURES ATTACHED TO MINI PAR BAR

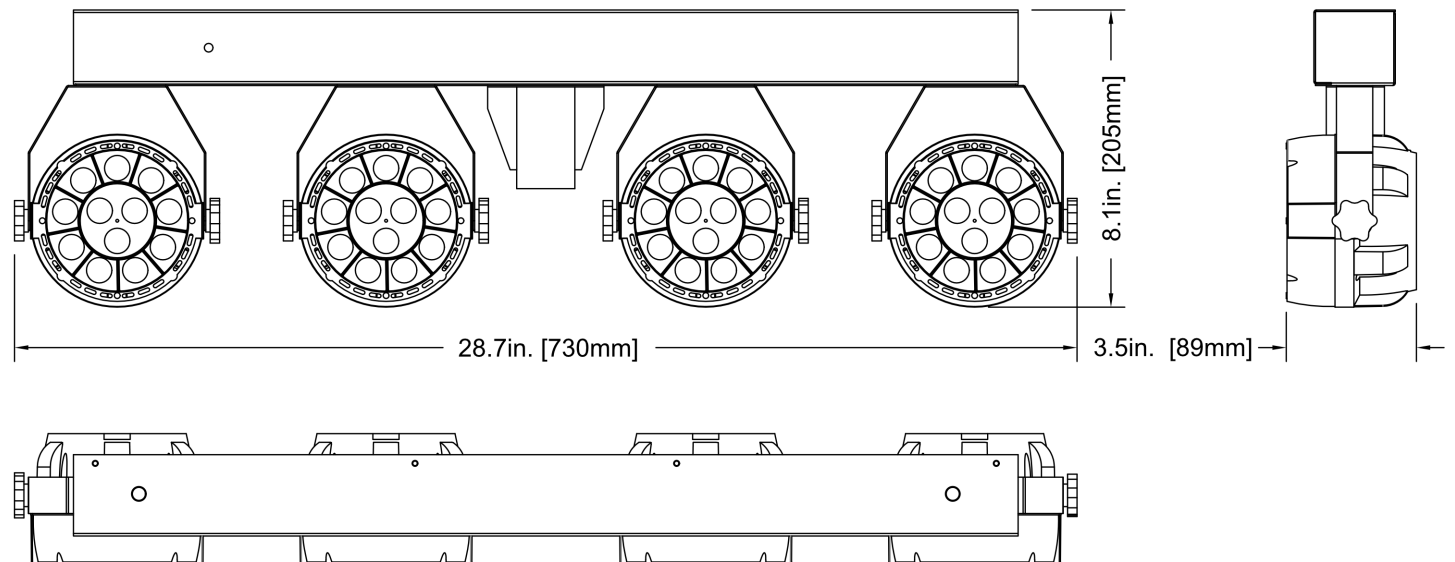

DIMENSIONAL DRAWING

TRIPOD STAND AND TRIPOD STAND WITH MINI PAR BAR

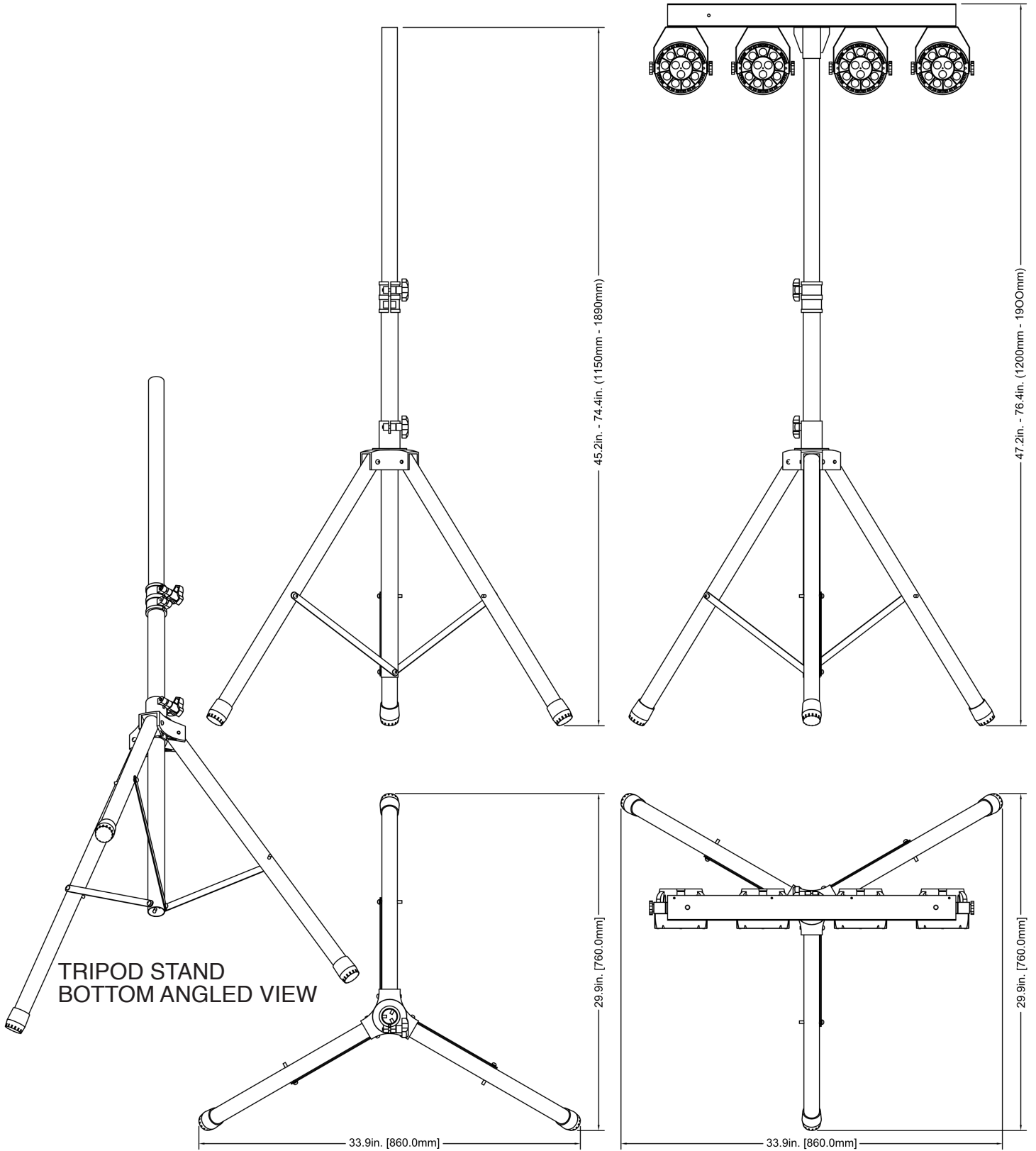

TRIPOD STAND WITH MINI PAR BAR

NOTE: Bottom illustration depicts tripod legs in fully deployed position.

DIMENSIONAL DRAWING

TRANSPORTATION BAG

