

ELIMINATOR[®]

LIGHTING

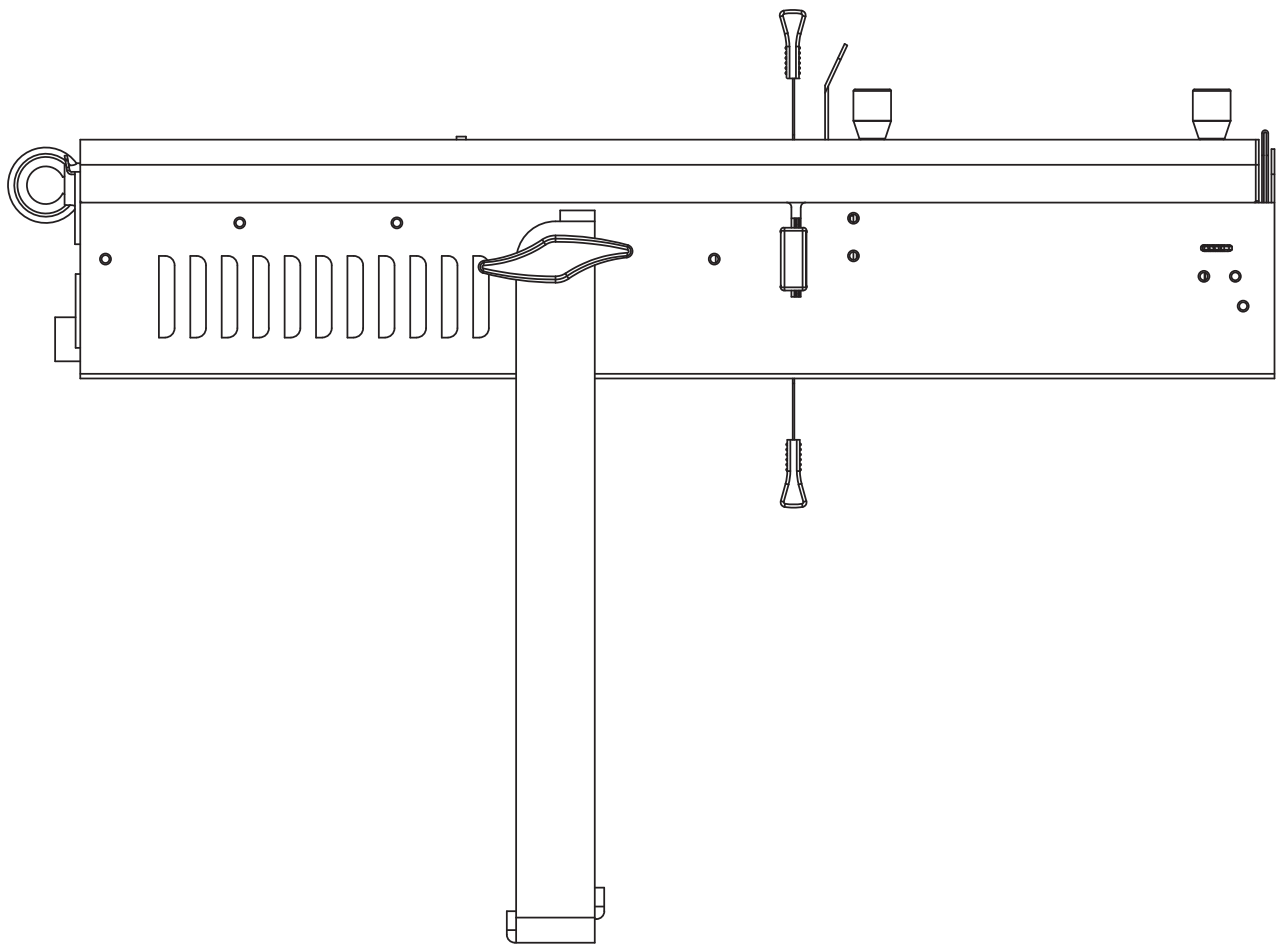

IKON PROFILE PLUS

User Manual

©2023 **Eliminator Lighting** all rights reserved. Information, specifications, diagrams, images, and instructions herein are subject to change without notice. Eliminator logo and identifying product names and numbers herein are trademarks of Eliminator Lighting. Copyright protection claimed includes all forms and matters of copyrightable materials and information now allowed by statutory or judicial law or hereinafter granted. Product names used in this document may be trademarks or registered trademarks of their respective companies and are hereby acknowledged. All non-Eliminator brands and product names are trademarks or registered trademarks of their respective companies.

Eliminator Lighting and all affiliated companies hereby disclaim any and all liabilities for property, equipment, building, and electrical damages, injuries to any persons, and direct or indirect economic loss associated with the use or reliance of any information contained within this document, and/or as a result of the improper, unsafe, insufficient and negligent assembly, installation, rigging, and operation of this product.

Eliminator Lighting

6122 S. Eastern Ave. Los Angeles, CA. 90040
323-582-2650 | Fax 323-532-2941 | www.adj.com | info@adj.com

ADJ SUPPLY Europe B.V

Junostraat 2 6468 EW Kerkrade, The Netherlands
+31 (0)45 546 85 00 | Fax +31 45 546 85 99
www.adj.eu | info@adj.eu

ADJ PRODUCTS GROUP Mexico

AV Santa Ana 30 Parque Industrial Lerma, Lerma, Mexico 52000
+52 (728) 282-7070

DOCUMENT VERSION



Due to additional product features and/or enhancements, an updated version of this document may be available online. Please check www.adj.com for the latest revision/update of this manual before beginning installation and/or programming.

Date	Document Version	Software Version >	DMX Channel Mode	Notes
10/12/23	1.0	1.00	3 / 4 Ch	Initial release

CONTENTS

General Information	4
Limited Warranty (USA Only)	5
Warranty Registration Features	6
Safety Guidelines	7
Overview	8
Installation Guidelines	9
System Menu	12
Operating Instructions	13
Primary Secondary Configuration	16
Remote Operation	17
DMX Setup	18
DMX Traits	21
Gobo Replacement Adding a Color Gel	22
Photometric Chart Gobos Fuse Replacement	23
Power Linking Trouble Shooting Cleaning	24
Dimensional Drawings	25
Specifications	26
FCC Statement	27

GENERAL INFORMATION

INTRODUCTION

This device is a 40W LED GOBO Projector that includes with 1 glass GOBO and 4 metal GOBOs. Users can also manually control the beam angle, focus, and framing shutters. Compatible with the UC IR wireless remote.

UNPACKING

This device has been thoroughly tested and has been shipped in perfect operating condition. Carefully check the shipping carton for damage that may have occurred during shipping. If the carton appears to be damaged, carefully inspect your fixture for damage and be sure all accessories necessary to operate the unit have arrived intact. In the event that damage has been found or parts are missing, please contact our customer support team for further instructions. Please do not return this fixture to your dealer without first contacting customer support at the number listed below. Please do not discard the shipping carton in the trash. Please recycle whenever possible.

CUSTOMER SUPPORT

Tel: (323) 213-4592 | Fax: (323) 582-2941

www.adj.com | support@eliminatorlighting.com

Warning! To prevent or reduce the risk of electrical shock or fire, do not expose this unit to rain or moisture.

Caution! Misuse of this device can result in eye injury. Avoid looking directly into the light source, and always exercise sensible precaution.

Caution! There are no user serviceable parts inside this unit. Do not attempt any repairs yourself, as doing so will void your manufacturer's warranty. In the event that your unit requires service, please contact Eliminator Lighting for assistance.

PLEASE recycle the shipping carton when ever possible.

LIMITED WARRANTY (USA ONLY)

- A. Eliminator Lighting, an ADJ Products, LLC brand, hereby warrants, to the original purchaser, Eliminator Lighting products to be free of manufacturing defects in material and workmanship for a prescribed period from the date of purchase (see specific warranty period on reverse). This warranty shall be valid only if the product is purchased within the United States of America, including possessions and territories. It is the owner's responsibility to establish the date and place of purchase by acceptable evidence, at the time service is sought.
- B. For warranty service, you must obtain a Return Authorization number (RA#) before sending back the product—please contact ADJ Products, LLC Service Department at 800-322-6337. Send the product only to the Eliminator Lighting factory. All shipping charges must be pre-paid. If the requested repairs or service (including parts replacement) are within the terms of this warranty, Eliminator Lighting will pay return shipping charges only to a designated point within the United States. If the entire instrument is sent, it must be shipped in its original package. No accessories should be shipped with the product. If any accessories are shipped with the product, Eliminator Lighting shall have no liability whatsoever for loss of or damage to any such accessories, or for the safe return thereof.
- C. This warranty is void if the serial number has been altered or removed; if the product is modified in any manner which Eliminator Lighting concludes, after inspection, affects the reliability of the product, if the product has been repaired or service by anyone other than ADJ Products, LLC factory unless prior written authorization was issued to purchaser by Eliminator Lighting; if the product is damaged because not properly maintained as set forth in the instruction manual.
- D. This is not a service contract, and this warranty does not include maintenance, cleaning or periodic check up. During the period specified above, Eliminator Lighting will replace defective parts at its expense with new or refurbished parts, and will absorb all expenses for warranty service and repair labor by reason of defects in material or workmanship. The sole responsibility of Eliminator Lighting under this warranty shall be limited to the repair of the product, or replacement thereof, including parts, at the sole discretion of Eliminator Lighting. All products covered by this warranty were manufactured after August 15, 2012, and bear identifying marks to that effect.
- E. Eliminator Lighting reserves the right to make changes in design and/or improvements upon its products without any obligation to include these changes in any products theretofore manufactured.
- F. No warranty, whether expressed or implied, is given or made with respect to any accessory supplied with products described above. Except to the extent prohibited by applicable law, all implied warranties made by Eliminator Lighting in connection with this product, including warranties of merchantability or fitness, are limited in duration to the warranty period set forth above. And no warranties, whether expressed or implied, including warranties of merchantability or fitness, shall apply to this product after said period has expired. The consumer's and/or Dealer's sole remedy shall be such repair or replacement as is expressly provided above; and under no circumstances shall Eliminator Lighting be liable for any loss or damage, direct or consequential, arising out of the use of, or inability to use, this product.
- G. This warranty is the only written warranty applicable to Eliminator Lighting products and supersedes all prior warranties and written descriptions of warranty terms and conditions heretofore published.

LIMITED WARRANTY PERIODS

- **All Eliminator Lighting products (except laser diodes) = 1-year (365 days) Limited Warranty** (Such as: Special Effect Lighting, Intelligent Lighting, UV lighting, Strobes, Fog Machines, Bubble Machines, Mirror Balls, Par Cans, Trussing, Lighting Stands etc. excluding LED and lamps)
- **Laser Products = 1 Year (365 Days) Limited Warranty** (excludes laser diodes which have 6 month limited warranty)
- **Batteries = 180 Day Limited Warranty** (excluding batteries which have a 180 day limited warranty)

WARRANTY REGISTRATION

This device carries a 2 year limited warranty. Please fill out the enclosed warranty card to validate your purchase. All returned service items, whether under warranty or not, must be freight pre-paid and accompanied by a return authorization (R.A.) number. The R.A. number must be clearly written on the outside of the return package. A brief description of the problem as well as the R.A. number must also be written down on a piece of paper included in the shipping carton. If the unit is under warranty, you must provide a copy of your proof of purchase invoice. You may obtain an R.A. number by contacting our customer support team on our customer support number. All packages returned to the service department not displaying an R.A. number on the outside of the package will be returned to the shipper.

FEATURES

- Bright 40W (9500K) white LED
- Adjustable LED brightness and strobing
- DMX control
- Wireless UC IR remote control
- One (1) textured glass gobo
- Manual control of beam angle, focus, and framing shutters

SAFETY GUIDELINES

Safety Issue: This unit may blow the fuse if the maximum current rating of the fuse is reached or exceeded. Please see the section of this manual for **Fuse Replacement** for detailed directions regarding replacement of the fuse.

- Be sure the voltage of the power source matches the required voltage of the unit.
- Disconnect from main power before making any type of connection.
- Do not remove the cover for any reason. There are no user serviceable parts inside.
- Always be sure to mount this unit in an area that will allow proper ventilation. Allow approximately 6.8' (2.1 meters) between this device and a wall.
- To reduce the risk of electrical shock or fire, do not expose this unit to rain or moisture.
- This unit is intended for indoor use only. Use of this product outdoors voids all warranties.
- During long periods of non-use, disconnect the unit from power.
- Always mount this unit in safe and stable matter.
- Power Cord Protection - Power-supply cords should be routed so that they are not likely to be walked on or pinched by items placed upon or against them, paying particular attention to cords at plugs, convenience receptacles, and the point where they exit from the fixture.
- Do not attempt to remove or break off the ground prong from the electrical cord. This prong is used to reduce the risk of electrical shock and fire in case of an internal short.
- A safety cable of the appropriate weight rating should always be used when this fixture is installed in a suspended location.
- The fixture should be serviced by qualified service personnel when:
 - A. The power cord or the plug has been damaged.
 - B. Objects have fallen, or liquid has been spilled into, the appliance.
 - C. The appliance has been exposed to rain or water.
 - D. The fixture does not appear to operate normally or exhibits a marked change in performance.

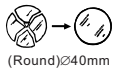

Replace shields, lenses or ultraviolet screens if they have become visibly damaged to such an extent that their effectiveness is impaired, for example by cracks or deep scratches. The light source shall be changed if it has become damaged or thermally deformed. The light source contained in this luminaire shall only be replaced by the manufacture or his service agent or a similar qualified person. The luminaire is intended for professional use only.



Caution, risk of electric shock.

If the external flexible cable or cord of this luminaire is damaged, it shall be exclusively replaced by the manufacturer or his service agent or a similar qualified person in order to avoid a hazard. Reinforced insulation was maintained between LV supply and DMX dimming control circuit.
- No insulation was maintained between SELV circuit and DMX dimming control circuit.



WARNING:

Caution! DO NOT stare into the beam, RG2

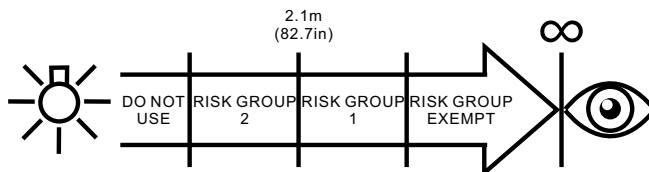

The luminaire should be positioned so that prolonged staring into the luminaire at a distance closer than 2.1 m is not expected.

Backup-restraint string should be used: made of steel, min. diameter 2.5mm.

OVERVIEW

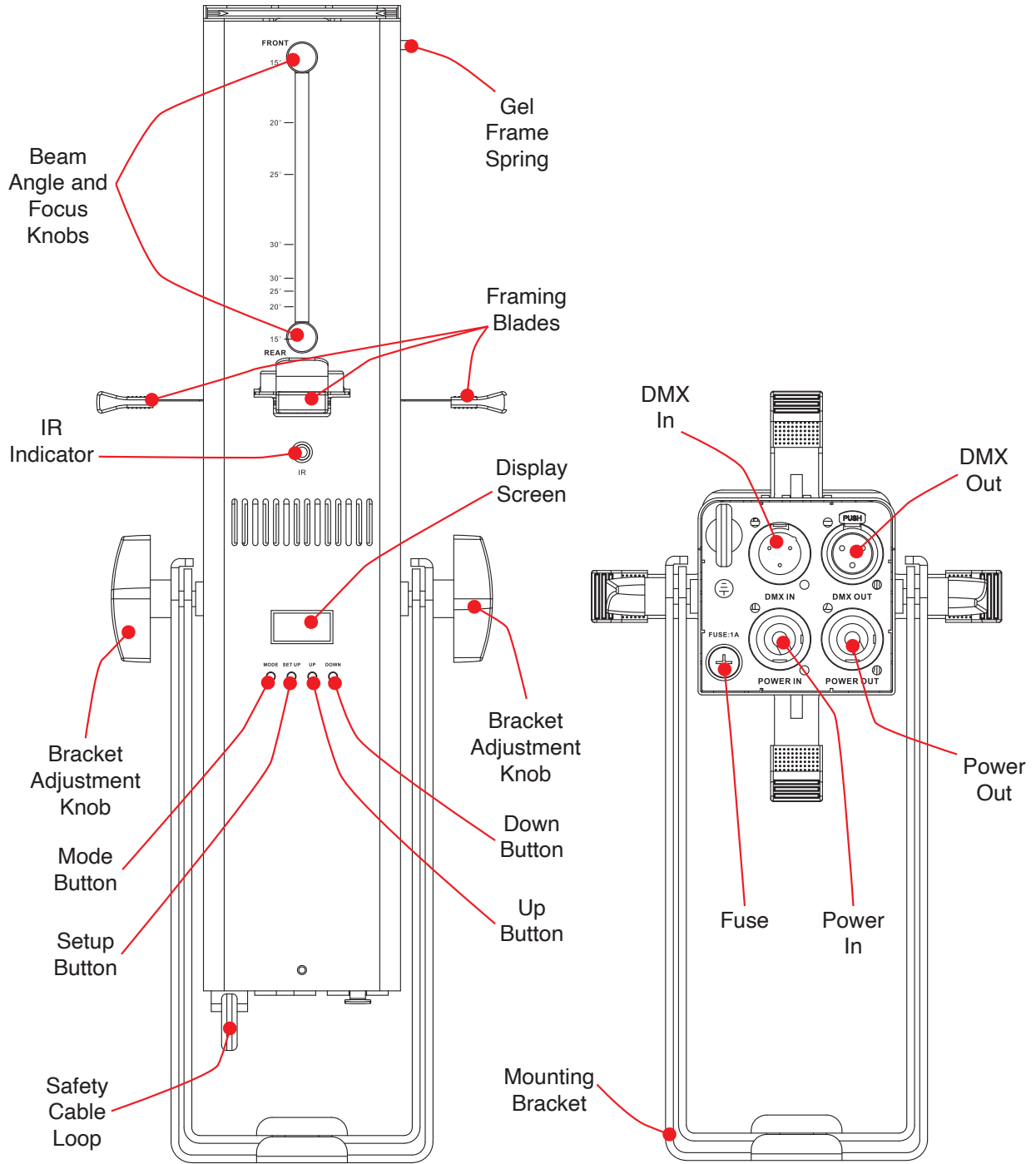

INSTALLATION GUIDELINES



ELECTRICAL CONNECTIONS

A qualified electrician should be used for all electrical connections and/or installations.

DO NOT INSTALL THE FIXTURE IF YOU ARE NOT QUALIFIED TO DO SO!

Fixture **MUST** be installed following all local, national, and country commercial electrical and construction codes and regulations. Before rigging/mounting the fixture to any metal truss/structure or placing the fixture on any surface, a professional equipment installer **MUST** be consulted to determine if the metal truss/structure or surface is properly certified to safely hold the combined weight of the fixture, clamps, cables, and accessories.

Overhead fixture installation must always be secured with a secondary safety attachment, such as an appropriately rated safety cable that meets all local, national, and country codes and regulations.

Fixture should be installed away from walking paths, seating areas, or areas where unauthorized personnel might reach the fixture by hand.

NEVER stand directly below the fixture when rigging, removing, or servicing.

Allow approximately 15-minutes for the fixture to cool down before servicing.

The unit should be mounted using a mounting clamp (not provided), and affixing it to the mounting bracket that is provided with the unit. Always ensure that the unit is firmly fixed to avoid vibration and slipping during operation. Always ensure that the structure that you are attaching the unit to is secure and is able to support at least 10 times the unit's weight. Also, always use a safety cable that can hold 12 times the unit's weight when installing the fixture. The equipment must be installed by a professional, and it must be installed in a place where it is out of the reach of people's grasp.

INSTALLATION GUIDELINES

CLAMP INSTALLATION

This device features an attachment point for a mounting clamp located on the top of the mounting bracket, as well as a loop for a safety cable located on the rear panel (see illustration below). When mounting the fixture to a truss or any other suspended or overhead installation, align the hole on an appropriately rated clamp (not included) with the hole on the fixture's bracket, then insert a bolt of the appropriate size and rating through the hole and secure in place with an appropriately rated nut. Attached a SAFETY CABLE of the appropriate rating to the provided attachment loop.

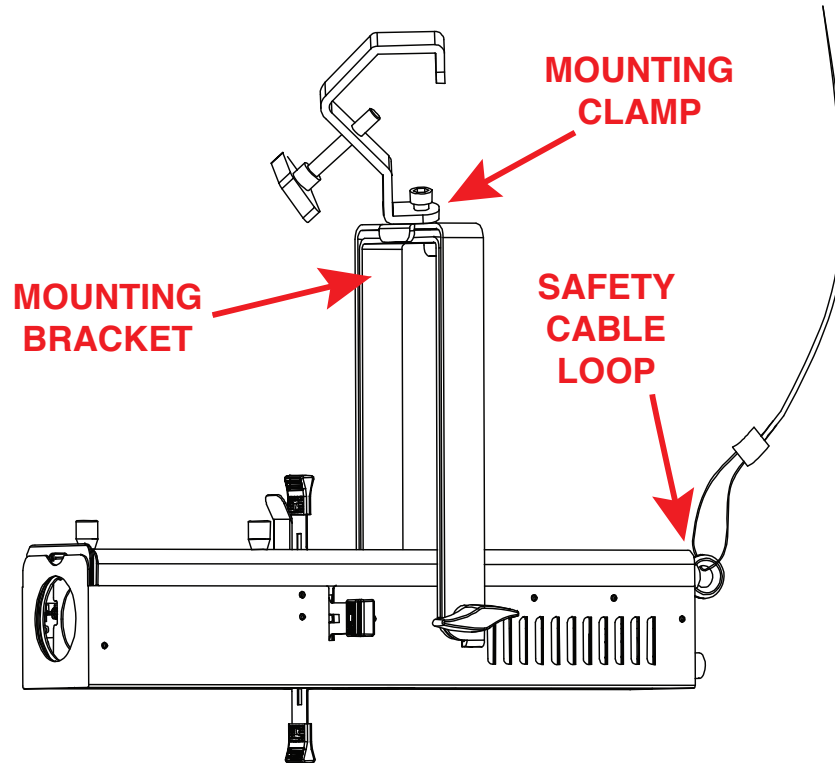

ALWAYS ATTACH A SAFETY CABLE WHENEVER INSTALLING THIS FIXTURE IN A SUSPENDED ENVIRONMENT TO ENSURE THAT THE FIXTURE WILL NOT FALL IN THE EVENT THAT THE CLAMP FAILS.

RIGGING

Overhead rigging requires extensive experience, including but not limited to: calculating working load limits, understanding the installation material being used, and periodic safety inspection of all installation material and the fixture itself. If you lack these qualifications, do not attempt to perform the installation yourself. Improper installation can result in bodily injury.

INSTALLATION GUIDELINES

FIXTURE INSTALLATION

This device is fully operational in three different mounting positions: hanging upside-down, mounted sideways on trussing, or set on a flat level surface. Be sure this fixture is kept at least 0.2m (7.9in.) away from any flammable materials (decoration etc.). Always use and install the supplied safety cable as a safety measure to prevent accidental damage and/or injury in the event the clamp fails. Never use the carrying handles for secondary attachment.

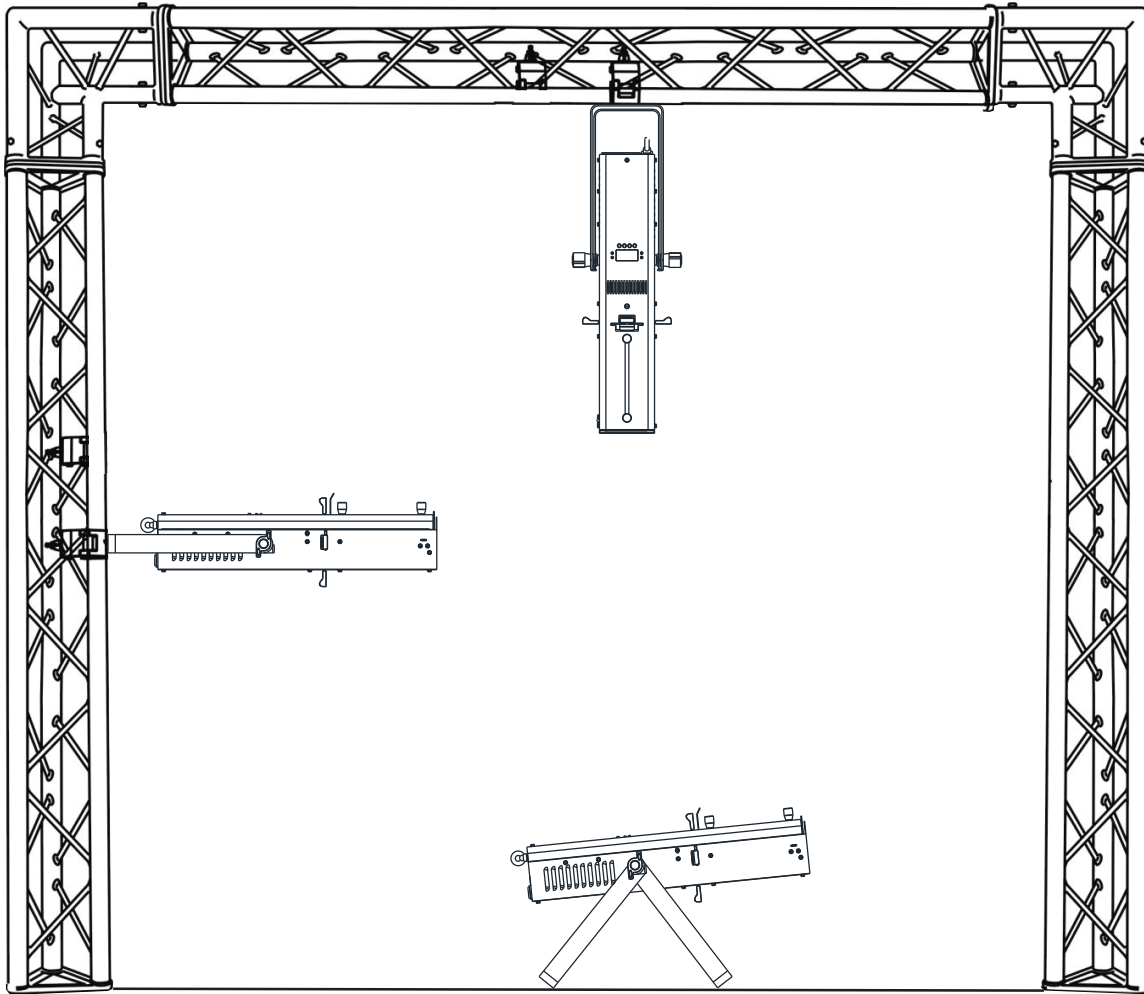

FALLING FIXTURES CAN CAUSE SEVERE INJURY OR SERIOUS EQUIPMENT DAMAGE! FOR THIS REASON, FIXTURES SHOULD BE INSTALLED AND INSPECTED ONLY BY QUALIFIED PERSONNEL. DO NOT INSTALL THE UNIT IF YOU LACK THE QUALIFICATIONS TO DO SO, OR IF YOU HAVE DOUBTS ABOUT THE SAFETY AND SECURITY OF THE INSTALLATION SETUP OR LOCATION!



ALWAYS ATTACH A SAFETY CABLE WHENEVER INSTALLING THIS FIXTURE IN A SUSPENDED ENVIRONMENT TO ENSURE THE FIXTURE WILL NOT FALL IF THE CLAMP FAILS.

SYSTEM MENU

DMX Settings	DMX Address	001 - 512		Set DMX address	
	Channel Mode	3Ch		Select DMX channel mode	
		4Ch			
	Blackout / Hold / Pri Sec	Black Out		Fixture takes all channels to zero when DMX signal is lost or interrupted	
Hold		Fixture holds most recent settings when DMX signal is lost or interrupted			
Pri Sec		Fixture default to primary-secondary mode when DMX signal is lost or interrupted			
Personality	Pri Sec Mode	Primary / Secondary		Set unit as a primary or a secondary unit	
	Dimmer Mode	Standard		Select dimmer mode	
		Stage			
		TV			
		Architectural			
		Theatre			
	IR	On / Off		Activate or deactivate remote control function	
		Display	Saver Delay	Off, 1 - 10sec	Display goes into screen saver mode after selected period of inactivity
	Screen Lock		Off - 30sec, 1 - 10min		Display controls lock after selected period of inactivity; to unlock, press and hold the MODE button for 3 seconds
	Rotate		dISP dSIP		Standard display orientation Inverted display orientation
Temperature Unit	C / F		Set temperature display units		
Service	Passcode = 011	Factory Restore	Yes / No	Reset unit to default factory settings	
Manual Control	Dimmer	000 - 255		Manually adjust dimmer	
	Strobe	000 - 255		Manually adjust strobing	
Information	Fixture Life Time Hours	xxxxx		Hours fixture has been powered on	
	LED Usage Time	xxxxx		Hours LED has been powered on	
	Firmware Version	Vx.x		Display current software version	

OPERATING INSTRUCTIONS

On-Board System Menu. This device features an easy to navigate system menu, with the functions of each command in the system menu detailed below. Please read the next section thoroughly!

To access the main menu press the MODE button, then press the UP or DOWN buttons until you reach the function you wish to change. Press the SETUP button to confirm. When a function is selected, use the UP or DOWN buttons to change the function settings. Once your changes are made, press the SETUP button, and then press and hold the MODE button for at least three seconds to confirm and lock the change into the system memory. If the MODE button is not pressed and held within eight seconds, the fixture will automatically confirm and lock the change into the system memory. To exit without making any changes, press the MODE button.

DMX SETTINGS - DMX Address:

1. Press the MODE button until “DMX Settings” is displayed, then press SETUP.
2. Use the UP and DOWN buttons to scroll to “DMX Address,” then press SETUP.
3. The current DMX address will now flash on the display screen. Press the UP or DOWN buttons to find your desired address. Press SETUP to set your desired DMX address.

NOTE: If the unit does not go into DMX mode after you connect your DMX controller, press and hold the MODE button for at least 3 seconds.

DMX SETTINGS - Channel Mode:

1. Press the MODE button until “DMX Settings” is displayed, then press SETUP.
2. Use the UP and DOWN buttons to scroll to “Channel Mode,” then press SETUP.
3. The current DMX channel mode will now flash on the display screen. Press the UP or DOWN buttons to find your desired channel mode, then press SETUP to confirm.

DMX SETTINGS - Black Out / Hold / Pri Sec (No DMX Setting): This setting controls how the fixture will behave when the DMX signal is lost or interrupted.

1. Press the MODE button until “DMX Settings” is displayed, then press SETUP.
2. Use the UP and DOWN buttons to scroll until either “Black Out”, “Hold”, or “Pri Sec” is displayed. This setting control how the device will behave when the DMX signal is lost or interrupted, and the currently selected option will be displayed. Press SETUP.
3. Press the UP or DOWN buttons to scroll through the options, then press SETUP to confirm. The available options are as follows:
 - *Black Out* - takes all channels to zero.
 - *Hold* - holds most recent settings.
 - *Pri Sec* - defaults to primary/secondary mode.

PERSONALITY - Pri Sec:

1. Press the MODE button until “Personality” is displayed, then press SETUP.
2. Use the UP and DOWN buttons to scroll to “Pri Sec Mode,” then press SETUP.
3. Press the UP or DOWN buttons to toggle between Primary and Secondary mode, then press SETUP to confirm your selection.

OPERATING INSTRUCTIONS

PERSONALITY - Dimmer Mode:

1. Press the MODE button until “Personality” is displayed, then press SETUP.
2. Use the UP and DOWN buttons to scroll to “Dimmer Mode,” then press SETUP.
3. Press the UP or DOWN buttons to scroll through the following options: Standard, Stage, TV, Architectural, Theatre, and Stage 2 (see the **Dim Curves** section of this manual for detailed information). Press SETUP to confirm the choice displayed on the screen.

PERSONALITY - IR: Use to activate or deactivate the remote control function.

1. Press the MODE button until “Personality” is displayed, then press SETUP.
2. Use the UP and DOWN buttons to scroll to “IR,” then press SETUP.
3. Press the UP or DOWN buttons to toggle between On (remote control function activated) and Off (remote control function deactivated), then press SETUP to confirm your selection.

PERSONALITY - Display - Saver Delay: The unit’s display screen will go into screen saver mode after the unit is inactive for the selected period of time.

1. Press the MODE button until “Personality” is displayed, then press SETUP.
2. Use the UP and DOWN buttons to scroll to “Display,” then press SETUP.
3. Use the UP and DOWN buttons to scroll to “Saver Delay”, then press SETUP.
4. Press the UP or DOWN buttons to set the amount of time the unit will be inactive before the screen goes into screen saver mode. Selectable options are “Off” or 1 to 10 seconds. Please note that when the “Off” option is selected, the screen will never go into screen saver mode.

PERSONALITY - Display - Screen Lock: The unit’s screen controls will lock after the unit is inactive for the selected period of time.

1. Press the MODE button until “Personality” is displayed, then press SETUP.
2. Use the UP and DOWN buttons to scroll to “Display,” then press SETUP.
3. Use the UP and DOWN buttons to scroll to “Screen Lock”, then press SETUP.
4. Press the UP or DOWN buttons to set the amount of time the unit will be inactive before the screen controls lock. Selectable options are “Off”, 30 seconds, or 1 to 10 minutes. Please note that when the “Off” option is selected, the screen controls will never lock. To unlock the screen, press and hold the MODE button for 3 seconds.

PERSONALITY - Display - Rotate:

1. Press the MODE button until “Personality” is displayed, then press SETUP.
2. Use the UP and DOWN buttons to scroll to “Display,” then press SETUP.
3. Use the UP and DOWN buttons to scroll to “Rotate”, then press SETUP.
4. Press the UP or DOWN buttons to toggle between “dISP” (normal display orientation) and “dSIP” (inverted display orientation). Press SETUP to confirm.

PERSONALITY - Temperature Unit:

1. Press the MODE button until “Personality” is displayed, then press SETUP.
2. Use the UP and DOWN buttons to scroll to “Temperature Display,” then press SETUP.
3. Use the UP and DOWN buttons to scroll to toggle between C and F, then press SETUP to confirm your selection.

OPERATING INSTRUCTIONS

PERSONALITY - Service: Use this setting to restore the unit to factory settings.

1. Press the MODE button until “Personality” is displayed, then press SETUP.
2. Use the UP and DOWN buttons to scroll to “Service,” then press SETUP.
3. Use the UP and DOWN buttons to key in the password (011 by default), then press SETUP to confirm.
4. When the screen displays “Factory Restore”, press SETUP to enter the sub-menu.
5. Use the UP and DOWN buttons to toggle between “Yes” and “No”. “Yes” resets all unit settings to factory default, and “No” returns you to the previous menu without making any changes.

MANUAL CONTROL - Dimmer:

1. Press the MODE button until “Manual Control” is displayed, then press SETUP.
2. Use the UP and DOWN buttons to scroll to “Dimmer,” then press SETUP.
3. Use the UP and DOWN buttons to scroll to the desired dimmer setting. Selectable values range from 000 to 255. Press SETUP to confirm your selection.

MANUAL CONTROL - Strobe:

1. Press the MODE button until “Manual Control” is displayed, then press SETUP.
2. Use the UP and DOWN buttons to scroll to “Strobe,” then press SETUP.
3. Use the UP and DOWN buttons to scroll to the desired strobe setting. Selectable values range from 000 to 255. Press SETUP to confirm your selection.

INFORMATION - Fixture Life Hours: Displays the number of hours the device has been powered on during its entire lifetime.

1. Press the MODE button until “Information” is displayed, then press SETUP.
2. Use the UP and DOWN buttons to scroll to “Fixture Life Hours,” then press SETUP. The screen will now show the number of hours the device has been powered on during its entire lifetime.
3. Press SETUP to return to the previous menu.

INFORMATION - LED Usage Time: Displays the number of hours the LED has been powered on.

1. Press the MODE button until “Information” is displayed, then press SETUP.
2. Use the UP and DOWN buttons to scroll to “LED Usage Time,” then press SETUP. The screen will now show the number of hours the LED has been powered on.
3. Press SETUP to return to the previous menu.

INFORMATION - Firmware Version:

1. Press the MODE button until “Information” is displayed, then press SETUP.
2. Use the UP and DOWN buttons to scroll to “Firmware Version,” then press SETUP. The screen will now show the current software version of the fixture.
3. Press SETUP to return to the previous menu.

PRIMARY SECONDARY CONFIGURATION

This function allows you to link units together to run in a Primary-Secondary set-up, in which one unit will act as the controlling unit and the others will react to the controlling unit's built-in programs. Any unit can be configured to act as a Primary or as a Secondary, but only one unit in a given system can be programmed to act as the Primary.

Primary-Secondary Connections and Settings:

1. Daisy chain your units via the XLR connectors on the rear panels of each unit. Use standard XLR data cables to link your units together. Remember that the male XLR connector is the input and the female XLR connector is the output. The first unit in the chain (primary) will use the female XLR connector only. The last unit in the chain will use the male XLR connector only.
2. For the unit that will be set as the primary, press the MODE button to navigate to Personality > Pri Sec Mode, then press SETUP. Use the UP and DOWN buttons to toggle this setting to "Primary", then press SETUP to confirm. Finally, set the unit to the desired operational mode.
3. For any unit(s) that will be set up as a secondary, press the MODE button to navigate to Personality > Pri Sec Mode, then press SETUP. Use the UP and DOWN buttons to toggle this setting to "Secondary", then press SETUP to confirm. The unit should now follow the primary unit.
4. Make sure that only one unit is designated as the Primary, while all other units are designated as Secondaries.

REMOTE OPERATION

The **UC IR** remote (sold separately) has many different functions and allows you to control your device at a distance of up to 30 ft.

STAND BY - This button blacks out the fixture.

FULL ON - This button has no valid function for this fixture.

STROBE - Press and hold this button to activate strobing.

FADE/GOBO - This button has no valid function for this fixture.

“DIMMER +” and “DIMMER -” - Use these buttons to adjust the output intensity.

1-9 - These buttons have no valid function for this fixture.

SOUND ON & OFF - These buttons have no valid function for this fixture.

SHOW - This button has no valid function for this fixture.

WIRELESS DMX INSTALLATION GUIDELINES

For best results, position the fixture so that the display screen is oriented in the direction of the transmitter device or remote.

Wireless signal can penetrate walls, glass, metal, and most objects. However, there are many factors that can effect and/or interrupt the wireless signal, including the presence of people. Therefore, it is highly recommended to position the wireless antenna a minimum of 9.8ft (3m) above audiences to ensure optimum and reliable wireless operation.

**9.8 ft (3m)
Above Ground**

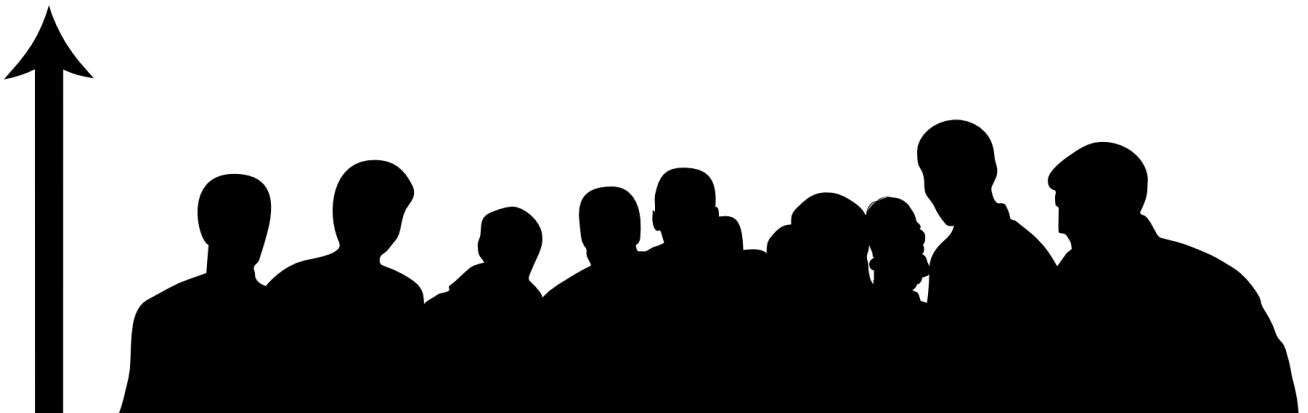

DMX SETUP

DMX-512: DMX is short for Digital Multiplex. This is a universal protocol that is used as a form of communication between intelligent fixtures and controllers. A DMX controller sends DMX data instructions from the controller to the fixture. DMX data is sent as serial data that travels from fixture to fixture via the DATA “IN” and DATA “OUT” XLR terminals located on all DMX fixtures (most controllers only have a DATA “OUT” terminal).

DMX Linking: DMX is a language allowing all makes and models of different manufacturers to be linked together and operate from a single controller, as long as all fixtures and the controller are DMX compliant. To ensure proper DMX data transmission, try to use the shortest cable path possible when linking several DMX fixtures together. The order in which fixtures are connected in a DMX line does not influence the DMX addressing. For example, a fixture assigned a DMX address of 1 may be placed anywhere in a DMX line: at the beginning, at the end, or anywhere in the middle. When a fixture is assigned a DMX address of 1, the DMX controller knows to send DATA assigned to address 1 to that unit, no matter where it is located in the DMX chain.

Data Cable (DMX Cable) Requirements (For DMX Operation): This device can be controlled via DMX-512 protocol, with 3 controllable DMX channels, as detailed in the **DMX Traits** section of this manual. The DMX address is set on the back panel of the fixture. Your unit and your DMX controller require a standard 3-pin XLR connector for data input and data output (Figure 1). We recommend Accu-Cable DMX cables. If you are making your own cables, be sure to use standard 110-120 Ohm shielded cable (This cable may be purchased at almost all pro lighting stores). Your cables should be made with a male XLR connector at one end and a female XLR connector at the other. Also remember that DMX cable must be daisy chained and cannot be split.



DMX SETUP

Notice: Be sure to follow figures two and three when making your own cables. Do not use the ground lug on the XLR connector. Do not connect the cable's shield conductor to the ground lug or allow the shield conductor to come in contact with the XLR's outer casing. Grounding the shield could cause a short circuit and erratic behavior.

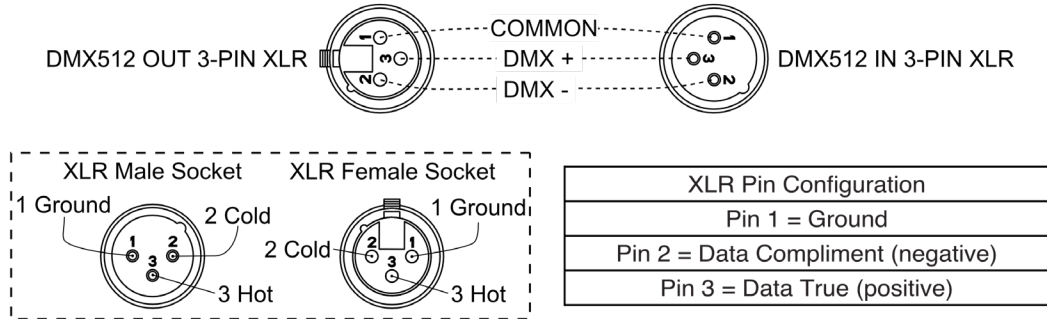

Special Note: Line Termination. When longer runs of cable are used, you may need to use a terminator on the last unit to avoid erratic behavior. A terminator is a 110-120 ohm 1/4 watt resistor which is connected between pins 2 and 3 of a male XLR connector (DATA + and DATA -). This unit is inserted in the female XLR connector of the last unit in your daisy chain to terminate the line. Using a cable terminator (ADJ part number Z-DMX/T) will decrease the chances of erratic behavior.

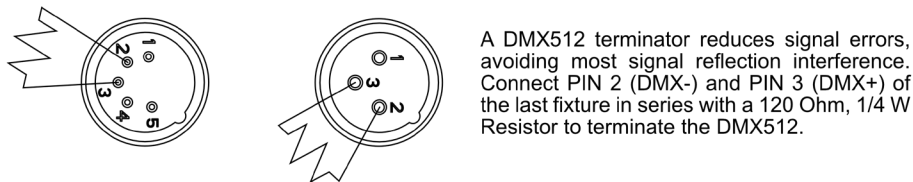

5-Pin XLR DMX Connectors. Some manufacturers use 5-pin DMX-512 data cables for DATA transmission in place of 3-pin. 5-pin DMX fixtures may be implemented in a 3-pin DMX line by using a cable adapter, which can readily be found at most electronics stores. The chart below details a proper cable conversion.



3-Pin XLR to 5-Pin XLR Conversion		
Ground/Shield	Pin 1	Pin 1
Data Compliment (- signal)	Pin 2	Pin 2
Data True (+ signal)	Pin 3	Pin 3
Not Used		Do Not Use
Not Used		Do Not Use

DMX SETUP

All fixtures should be given a DMX starting address when using a DMX controller, so the correct fixture responds to the correct control signal. This digital starting address is the channel number from which the fixture starts to “listen” to the digital control signal sent out from the DMX controller. The assignment of this starting DMX address is achieved by setting the correct DMX address on the digital control display on the fixture.

You can set the same starting address for all fixtures or a group of fixtures, or set different addresses for each individual fixture. Setting all fixtures to the same DMX address will cause all fixtures to react in the same way, in other words, changing the settings of one channel will affect all the fixtures simultaneously.

If you set each fixture to a different DMX address, each unit will start to “listen” to the channel number you have set, based on the quantity of DMX channels of each fixture. That means changing the settings of one channel will only affect the selected fixture. For example, when operating this 3-channel unit, you should set the starting DMX address of the first unit to 1, the second unit to 4 (1 + 3), the third unit to 7 (1 + 3 + 3), etc...

Channel Mode	Unit 1 Address	Unit 2 Address	Unit 3 Address	Unit 4 Address
3Ch	1	4	7	10
4Ch	1	5	9	13

DMX TRAITS

CHANNEL MODE		DMX VALUES	FUNCTION
3Ch	4Ch		
1	1		<i>Strobe</i>
		000 - 031	LED Off
		032 - 063	LED On
		064 - 095	Strobe, slow to fast
		096 - 127	LED On
		128 - 159	Strobe Pulse, slow to fast
		160 - 191	LED On
		192 - 223	Random Strobe, slow to fast
		224 - 255	LED On
2	2	000 - 255	<i>Dimmer</i>
	3	000 - 255	<i>Dimmer Fine</i>
3	4		<i>Dim Curves</i>
		000 - 020	Standard
		021 - 040	Stage
		041 - 060	TV
		061 - 080	Architectural
		081 - 100	Theatre
		101 - 120	Stage 2
		121 - 255	Default to Unit Setting

GOBO REPLACEMENT

The gobo in this device can be interchanged at any time, allowing the user to customize the system. To replace gobo, follow the steps below:

1. Locate the gobo housing in front of the top framing blade, then gently slide the gobo housing out of the top of unit.
2. Use a pair of needle nose pliers to carefully remove the retaining ring that holds the gobo in the gobo housing.
3. Remove and replace the gobo with the desired replacement. Reinsert the retainer ring, making sure the ring rests firmly against the gobo.
4. Slide the gobo assembly back into place.

ADDING A COLOR GEL

A color gel (not included) can be added to the front of this unit and can be interchanged at any time. This allows the user to customize the system. To add a color gel, follow the steps below:

1. Locate the color gel frame at the front of the unit. Slide the spring lever back and slide the gel frame out of the holder.
2. Once the gel frame has been removed, slide your desired color gel into the middle of the frame.
3. Slide the spring back and slide the gel frame into place.

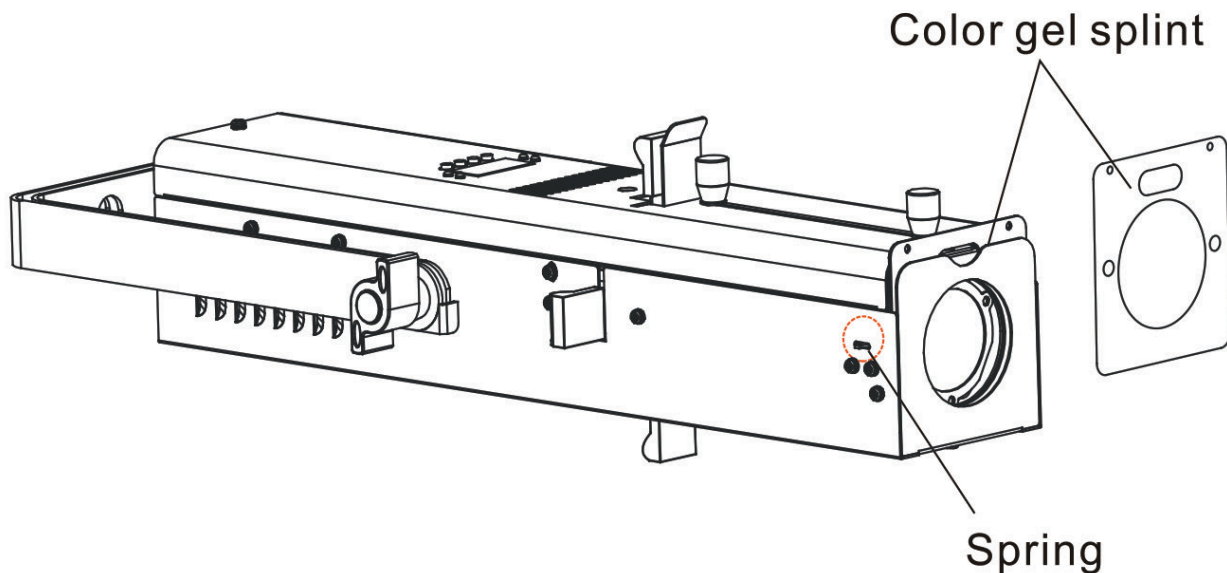

PHOTOMETRIC CHART

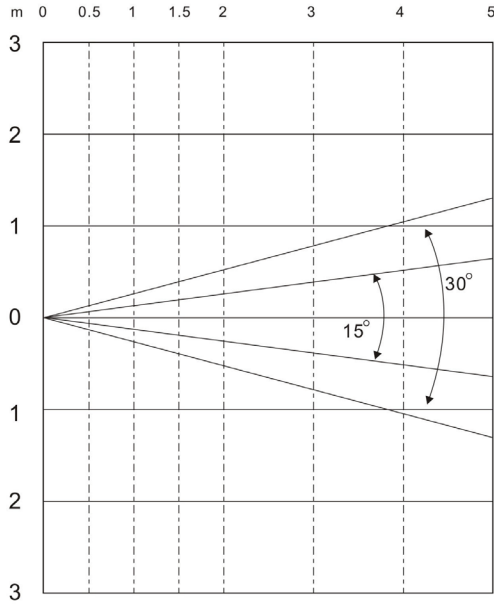

Ikon Profile Plus

		1m	2m	3m	4m	5m	
15°	CW	0.26	0.52	0.78	1.04	1.30	Diameter (Meters) LUX
		41490	8404	3981	2169	1400	
30°	CW	0.54	1.08	1.62	2.16	2.70	Diameter (Meters) LUX
		10820	2451	1080	576	382	

GOBOS

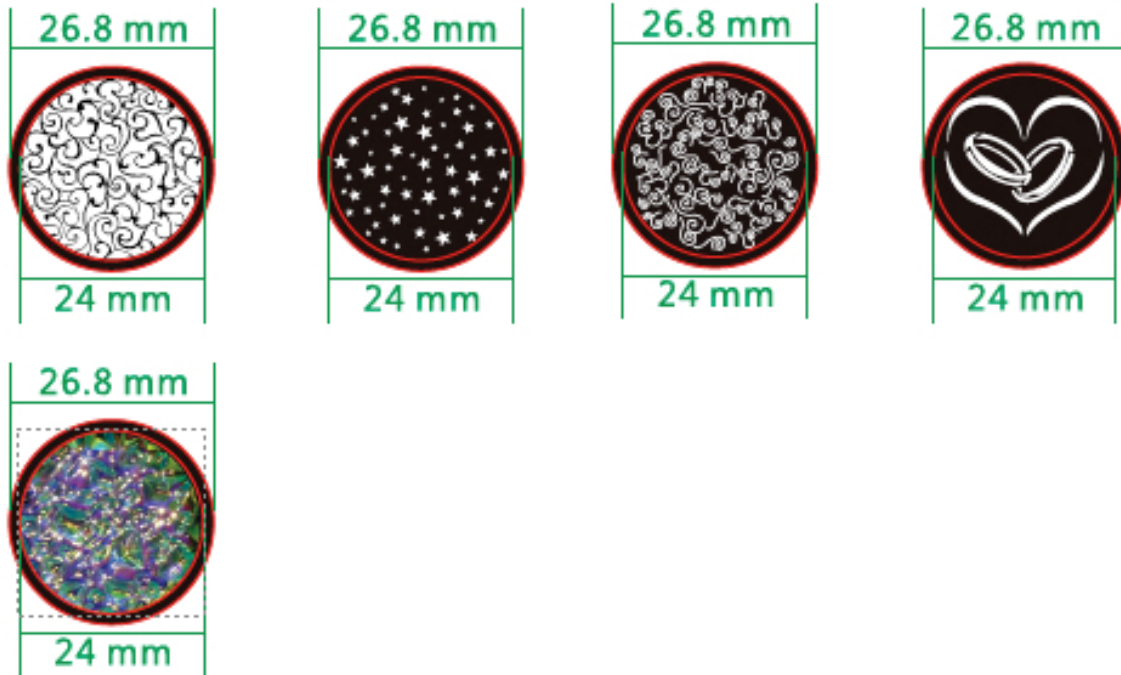

FUSE REPLACEMENT

Disconnect the unit from its power source. Remove the power cord from the unit, then find the fuse holder located inside the power socket. Use a philips-head screw driver to remove the fuse holder, then remove the bad fuse and replace with a new one of the same rating (T1A).

POWER LINKING

This feature allows multiple units to be linked together by way of the power input and output sockets.

The maximum number of devices that can be connected in this manner is as follows:

14 units maximum @ 120V.

24 units maximum @ 230V

After this quantity has been reached, a new power outlet must be used to accommodate additional devices.

Linked devices must be of the same make and model type. DO NOT mix devices!

TROUBLE SHOOTING

Below is a common problem that the user may encounter, with possible solutions.

No light output from the fixture:

- Check that the fuse has not blown. The fuse is located on the rear panel of the fixture.
- Check that the 4 framing blades are not in the closed position.

CLEANING

Due to fog residue, smoke, and dust, cleaning of the internal and external optical lenses must be carried out periodically in order to optimize light output.

- Use normal glass cleaner and a soft cloth to wipe down the outside casing.
- Clean the external optics with glass cleaner and a soft cloth.
- Always be sure to dry all parts completely before plugging the unit back in.

Cleaning frequency depends on the environment in which the fixture operates (i.e. smoke, fog residue, dust, dew).

DIMENSIONAL DRAWINGS

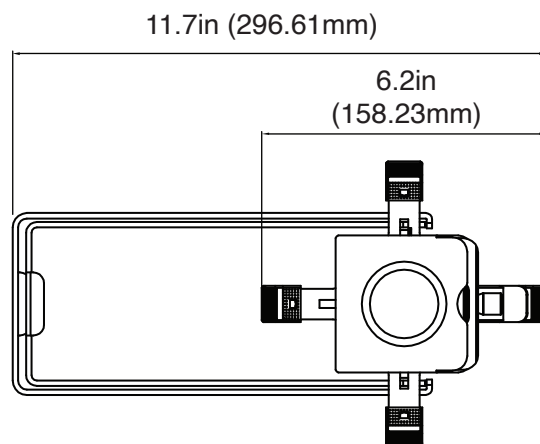
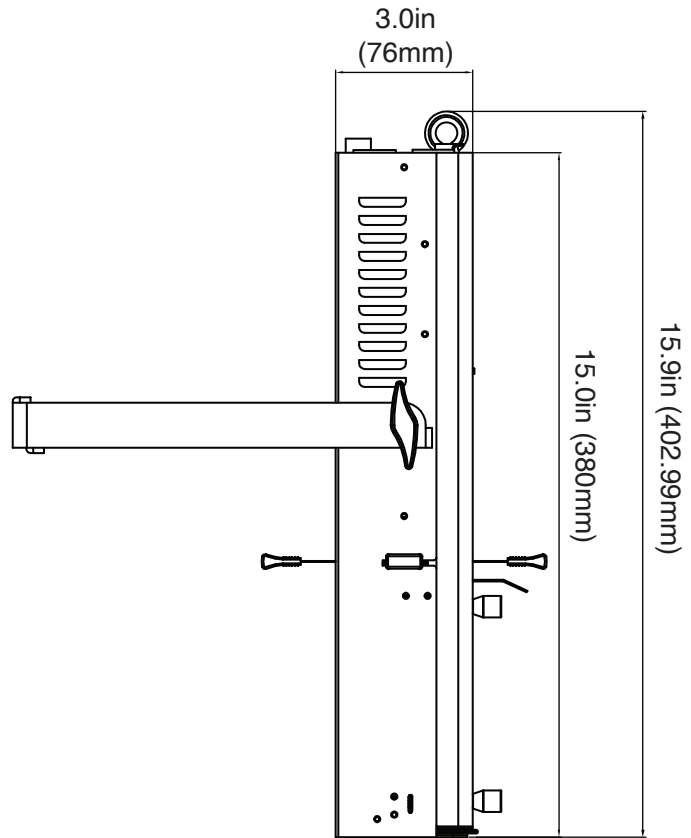
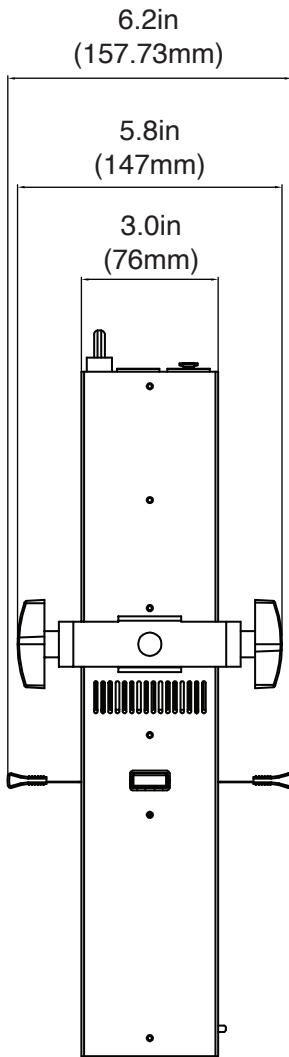

SPECIFICATIONS

- Bright white 40W LED indoor Gobo Projector
- High quality optics - Clear powerful output
- 3-channel or 4-channel DMX channel modes
- 5 Dimmer Curves
- Beam Angle: 15-30 degrees
- Adjustable Beam Angle and Focus
- Manual Framing Shutters
- Includes Textured Glass Gobo
- One Glass Gobo Installed, 4 Metal Gobos Included
- Gobo size: 26.8mm; Viewable size: 24mm
- Drop in Gobo Slot for Metal or Glass Gobos
- Color Frame For Color Filters
- Run all night – No Duty Cycle
- Ideal for Mobile DJs, Clubs, Bars, Retail Stores and Promotional Events
- Very low heat output
- Long life LED (Rated at approximately 50,000 hrs.)
- With Wired Digital Communication Network
- Power in/power out outlets on rear panel to daisy chain power (up to 14 units @ 120V and 24 units @ 230V)
- Includes yoke to mount on a wall or hang from trussing
- UC IR Remote Control
- Multi-voltage: 100-240V, 50/60Hz• Power consumption: 44W max
- Dimensions (LxWxH): 17.75" x 6" x 5" / 448 x 149 x 127mm
- Weight: 6 lbs. / 2.7 kg.
- ETL Approved
- FCC Approval

FCC STATEMENT

This device complies with Part 15 of the FCC Rules. Operation is subject to the following two conditions: (1) this device may not cause harmful interference, and (2) this device must accept any interference received, including interference that may cause undesired operation.

FCC RADIO FREQUENCY INTERFERENCE WARNINGS & INSTRUCTIONS

This product has been tested and found to comply with the limits for a Class A digital device, pursuant to Part 15 of the FCC Rules. These limits are designed to provide reasonable protection against harmful interference when the equipment is operated in a commercial environment. This equipment generates, uses, and can radiate radio frequency energy and, if not installed and used in accordance with the instructions in this manual, may cause harmful interference to radio communications. Operation of this equipment in a residential area is likely to cause harmful interference, in which case the user will be required to correct the interference at his own expense.

Europe Energy Saving Notice

Energy Saving Matters (EuP 2009/125/EC)

Saving electric energy is a key to help protecting the environment. Please turn off all electrical products when they are not in use. To avoid power consumption in idle mode, disconnect all electrical equipment from power when not in use. Thank you



