

User Manual

# LCRP-12

Series Relay Panels



# LynTec

LynTec.com | 800.724.4047

Power Control Simplified

## HAZARD CATEGORIES AND SPECIAL SYMBOLS

Read these instructions carefully and look at the equipment to become familiar with the device before trying to install, operate, service, or maintain it. The following special messages may appear throughout this bulletin or on the equipment to warn of potential hazards or to call attention to information that clarifies or simplifies a procedure.



The addition of either symbol to a "Danger" or "Warning" safety label indicates that an electrical hazard exists which will result in personal injury if the instructions are not followed.



This is the safety alert symbol. It is used to alert you to potential personal injury hazards. Obey all safety messages that follow this symbol to avoid possible injury or death.

### **DANGER**

DANGER indicates an immediately hazardous situation which, if not avoided, **will result in** death or serious injury.

### **WARNING**

WARNING indicates a potentially hazardous situation which, if not avoided, **can result in** death or serious injury.

### **CAUTION**

CAUTION indicates a potentially hazardous situation which, if not avoided, **can result in** minor or moderate injury.

### **CAUTION**

CAUTION, used without the safety alert symbol, indicates a potentially hazardous situation which, if not avoided, **can result in** property damage.

*NOTE: Provides additional information to clarify or simplify a procedure.*

## PLEASE NOTE

Electrical equipment should be installed, operated, serviced and maintained only by qualified electrical personnel. This document is not intended as an instruction manual for untrained persons. No responsibility is assumed by LynTec for any consequences arising out of the use of this manual.

## Class A FCC Statement

**Chapter 1--Introduction ..... 1**

    Overview ..... 1

    Contents ..... 1

**Chapter 2--Safety Precautions ..... 2**

**Chapter 3--Quick Start Guide ..... 3**

    Introduction ..... 3

**Chapter 4--Wiring ..... 4**

    Power Wiring ..... 5

    Relay Wiring ..... 5

        Emergency Lighting Wiring ..... 6

        Completion Contact Wiring ..... 6

**Chapter 5--Setup ..... 8**

    Menu Options ..... 8

        Circuit Select Menu ..... 8

        Address Menu (Addr) ..... 9

        On Threshold Menu (t on) ..... 9

        OFF Threshold Menu (toff) ..... 9

        DMX Sense Menu (dSnS) ..... 9

        DMX Sense Timeout Menu (Sout) ..... 10

        Brownout Menu (bo) ..... 10

        Emergency Lighting Menu (El) ..... 10

        Completion Relay Menus (C on & CoFF) ..... 11

        Nominal Voltage Selection Menus (VrnG & VoLt) ..... 11

        Emergency Relay Menus (EoCC & ELCC) ..... 12

        Brownout Enable/Disable (boEn) ..... 12

        Display Brightness (brGt) ..... 13

        Factory Reset (rSEt) ..... 13

        Information Menu (InFo) ..... 13

        Test Menu (teSt) ..... 13

## Chapter 1--Introduction

### OVERVIEW

This bulletin explains how to install and operate the LynTec Lighting Control (LCRP) relay panel. The LCRP-12 can control up to 12 relays. Control signals originate externally from a DMX source.

### CONTENTS

Each LCRP comes standard with the following components installed:

- LCRP Controller
- Transformer
- Relay Driver to control 4, 8 or 12 relays

## Chapter 2--Safety Precautions

This chapter contains important safety precautions that must be followed before attempting to install, service, or maintain electrical equipment. Carefully read and follow the safety precautions below.

READ AND FOLLOW ALL SAFETY INSTRUCTIONS

 **DANGER**

HAZARD OF ELECTRIC SHOCK, EXPLOSION, OR ARC FLASH  
This equipment must be installed and serviced only by qualified electrical personnel.

- Apply appropriate personal protective equipment (PPE) and follow safe electrical work practices. See NFPA 70E.
- Turn off all power supplying this equipment before working on or inside equipment.
- Always use a properly rated voltage sensing device to confirm that power is off.
- Replace all devices, doors, and covers before turning on power to this equipment.

Failure to follow this instruction will result in death or serious injury.

IMPORTANT SAFEGUARDS

When using electrical equipment, basic safety precautions should always be followed including the following:

READ AND FOLLOW ALL SAFETY INSTRUCTIONS.

- Do not use outdoors unless the enclosure is rated for outdoor use
- Do not mount near gas or electric heaters.
- Equipment should be mounted in locations and at heights where it will not readily be subjected to tampering by unauthorized personnel.
- The use of accessory equipment not recommended by the manufacturer may cause an unsafe condition.
- Do not use this equipment for other than intended use.

SAVE THESE INSTRUCTIONS

## Chapter 3--Quick Start Guide

### INTRODUCTION

This chapter is a quick reference listing the steps necessary to install the LCRP system. The steps in this chapter are provided as an installation checklist. For complete installation instructions, refer the chapter listed.

Steps	Reference
1. Mount the LCRP at your preferred location as allowed by code.	<b>Local Electrical Code</b>
2. Wire the power transformer.	<b>Chapter 4--Wiring</b>
3. Wire each individual circuit.	<b>Chapter 4--Wiring</b>
4. Connect the DMX source.	<b>Chapter 4--Wiring</b>
5. Complete the relay panel setup.	<b>Chapter 5--Control Setup</b>
6. If your LCRP system does not operate as expected, verify that everything is installed and programmed correctly.	<b>Appendix A--Troubleshooting</b>

# Chapter 4--Wiring

Figure 4-1: LCRP-12

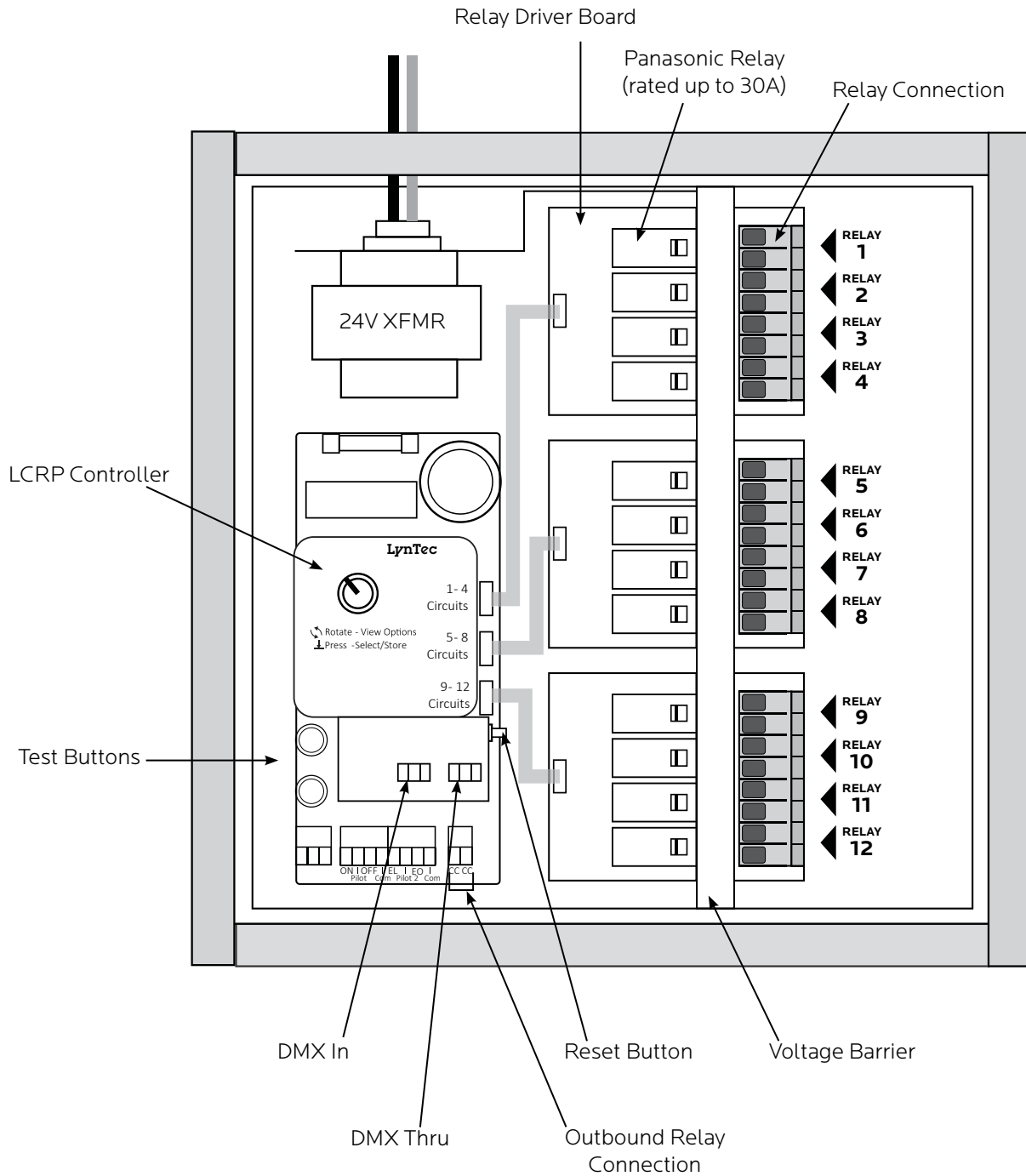

**POWER WIRING**

To initially wire the LCRP, connect the power breaker in your panel to the transformer in the LCRP.

**Figure 4-2: 24V Power Transformer**

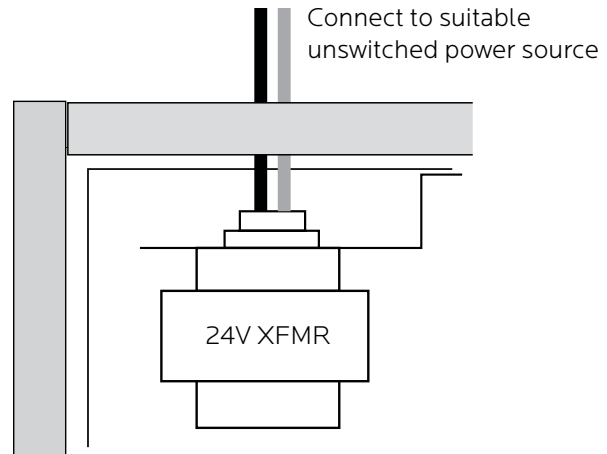

**RELAY WIRING**

To wire individual relays, bring the hot from the breaker to the first terminal for the desired relay. Then run another conductor from the second relay terminal to the load.

**Figure 4-3: Relay Driver Board**

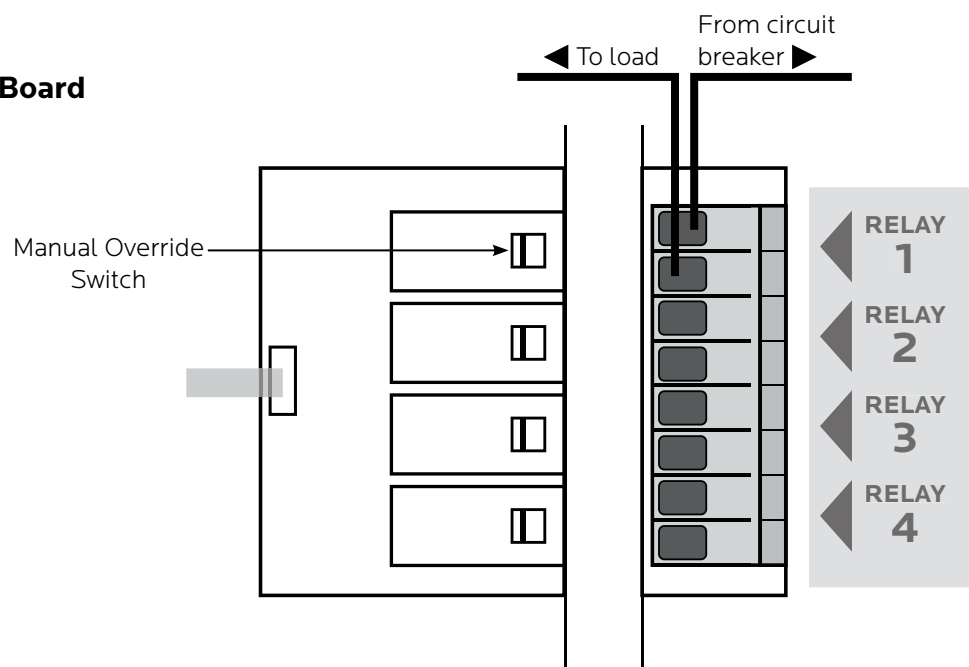



## Emergency Lighting Wiring

From the fire alarm unit or latching Emergency Lighting switch, wire the Normally Open (NO) contacts to the “EL” and “Com” positions on the LCRP Controller.

**Figure 4-8: Wiring for Emergency Lighting**

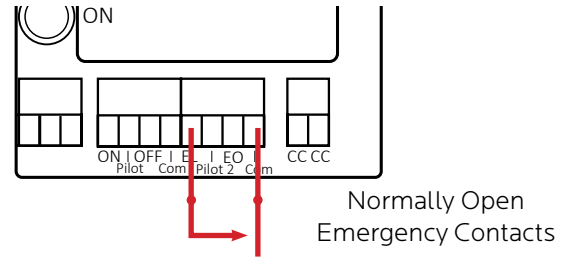

## Completion Contact Wiring

From the desired unit, wire the Normally Open (NO) contacts to the “CC” and “CC” positions on the LCRP Controller.

**Figure 4-9: Wiring for Completion Contacts**

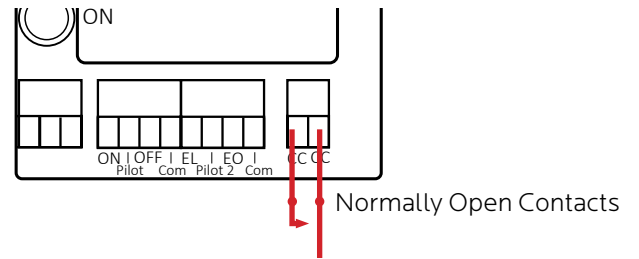

**INITIAL POWER UP  
PROCEDURE**

With the circuit breaker panel door open and breakers visible, turn on the Controller Power 15 Amp circuit breaker.

The red “Status” LED should illuminate on the LCRP Controller and “LynTec LCRP-12” will scroll across the screen.

Use the red and green test buttons to test relay operation.

Please note that the test buttons and normal sequencing signals are disabled when a DMX signal is detected regardless of DMX sense settings.

EO/EL will override DMX signal settings, but individual circuit settings allow customization of the response. BO is enable by default, but can be disabled in the normal manner.

## Chapter 5--Setup

LCRP-12 setup is achieved via a dial on the LCRP Controller. The dial is rotated to view options and pressed to select and store options. The dial can rotate left or right and also be pressed in for menu selection and control. The screen will timeout after 30 seconds and clear anything not saved.

Note: It is advised to not have DMX signal active during setup. Having a DMX signal active during setup reduces the responsiveness of the dial.

**Figure 5-1: LCRP Controller Dial**

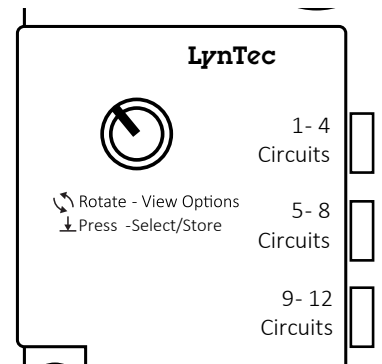

## MENU OPTIONS

### Circuit Select Menu

The Circuit Select Menu will appear any time changes are made to individual circuits. All circuit LEDs will go Green except the selected circuit which will alternate between red & green.

When the desired circuit has been selected, press the dial to move to the next option for that circuit.

On menus where the circuit ON/OFF is selected, green designates OFF & red designates ON.

To save changes, press the dial in for 2 seconds to ensure all changes are saved to memory. "SAVd" will display on the screen when saving is complete.

**Address Menu (Addr)**

Changes the starting address for the sequential DMX addressing. Valid range is from 1-512 minus the number of circuits. For example a 12 circuit LCRP-12 would have the highest valid starting address of 501. The address is changed one digit at a time. Least significant first to most significant. Encoder press will move to the next digit until all digits are complete and saves the new address. Default address is 001.

**On Threshold Menu (t on)**

Changes the the threshold level for DMX to turn the circuit ON. The on threshold is limited in range from 145 to 239. The default value is 192 (75%).

The threshold is changed one digit at a time. Least significant first to most significant. Encoder press will move to the next digit until all digits are complete and saves the new threshold level.

**OFF Threshold Menu (toff)**

Changes the the threshold level for DMX to turn the circuit OFF. The on threshold is limited in range from 17 to 111. The default value is 64 (25%).

The threshold is changed one digit at a time. Least significant first to most significant. Encoder press will move to the next digit until all digits are complete and saves the new threshold level.

**DMX Sense Menu (dSnS)**

This menu enables or disables DMX sense. This will cause ALL circuits to turn ON when a DMX signal is detected. Circuits will turn OFF based on the next timeout setting.

There is no individual circuit control when DMX Sense is enabled.

## **DMX Sense Timeout Menu (Sout)**

DMX Sense Timeout is the time without a DMX signal before ALL circuits are automatically turned OFF.

Default is 5 minutes. Options are 1, 2, 5, 10 minutes. Press to save the selection and return to main menu.

## **Brownout Menu (bo)**

This feature changes the circuit state for circuits during a under-voltage (brownout) or over-voltage condition. The default setting is all circuits set to turn off during either voltage condition.

Pressing the dial will activate the Circuit Select Menu. The current setting for the selected circuit will be displayed. Press the dial to change the state. Rotating left will select "OFF" and right will select "ON"

Press to save the selection and return to Circuit Select Menu.

When all changes to individual circuits have been made. Press to save the selection and return to main menu.

## **Emergency Lighting Menu (El)**

This feature allows you to select which individual circuits should turn on in the event of an emergency. This feature is disabled by default.

Pressing the dial will activate the Circuit Select Menu. The current setting for the selected circuit will be displayed. Press the dial to change the state. Rotating left will select "OFF" and right will select "ON"

Press to save the selection and return to Circuit Select Menu.

When all changes to individual circuits have been made. Press to save the selection and return to main menu.

### Completion Relay Menus (C on & CoFF)

These two menus allow you to select which individual circuits trigger the completion relay. The default ON circuit is the last circuit and the default OFF circuit is the first circuit.

Pressing the dial will activate the Circuit Select Menu. Rotate the dial to select the desired circuit. The current setting for the selected circuit will be displayed. Press the dial to change the state.

Press to save the selection and return to Circuit Select Menu.

When all changes to individual circuits have been made. Press to save the selection and return to main menu.

### Nominal Voltage Selection Menus (VrnG & VoLt)

These menus allow you to set the nominal voltage for under-voltage (brownout) or over-voltage monitoring. Do not change this setting without changing out the transformer hardware.

The VrnG menu sets the voltage range. Exact voltages are selected in the next menu. Press to open the VrnG menu and turn the dial to select 120C, 240V or 277V as the voltage range. The factory setting is based on the model ordered.

Press to save the selection and return to main menu.

The VoLt menu allows to refine the nominal voltage within the selected range. For example, in the 120V range, you may choose any nominal voltage between 100V - 130V in 1 volt increments. See table 5-1 for ranges and increments.

**Table 5-1: Voltage Settings**

Press to save the selection and return to main menu.

Setting	Range	Increment
120V	100V - 130V	1 volt
240V	200V - 260V	5 volts

## **Emergency Relay Menus (EoCC & ELCC)**

The default input type for EL and EO features is Normally Open. You may change the type to Normally Closed in these menus.

Press the dial to display the current setting. Rotate to change the setting.

Press to save the selection and return to main menu.

## **Brownout Enable/Disable (boEn)**

This feature allows you to enable or disable the brownout (under or over-voltage) protection. The default setting is ENABLED. To disable, press to open the menu, then rotate.

Press to save the selection and return to main menu.

PLEASE NOTE: If brownout is disabled, the start up voltage check is also disabled. The normal start time requirement for this is 5 seconds. Control is only possible after this check is complete. Disabling Brown out removes this start up time check, enabling it conversely ensures that voltage is good before making changes.

**Display Brightness (brGt)**

This menu changes the brightness of the display. The screen will not blink, but left/right will decrease/increase the brightness in real time.

Press to save the selection and return to main menu.

**Factory Reset (rSEt)**

To reset the LCRP-12 to factory settings press the dial to confirm.

CAUTION: This action restores everything to default configuration. All settings will be lost. The LCRP-12 will automatically restart.

**Information Menu (InFo)**

This menu shows the current firmware version of the LCRP-12.

Press to return to main menu.

**Test Menu (teSt)**

When pressed, circuit 1 will turn on. Turn the dial to the right will turn OFF circuit 1 and then turn ON circuit 2 at a half second interval. This will repeat for as many circuits as are installed. Turn the dial to the left to reverse the circuit OFF / ON sequence.

This will NOT time out. A second press of the encoder button is required to end the TEST mode.

Press to return to main menu.