



AND-BTN-KIT-1

AND Button Kit

Overview

Enable two-way communication with the push of a button by connecting the AND Button Kit (AND-BTN-KIT-1) to a compatible IP device.

When connected to a compatible IP device, the AND-BTN-KIT-1 easily integrates with VoIP phone systems, approved 3rd party software, and includes ClockWise Campus software with purchase.

Description



AUDIO FUNCTIONALITY

Intercom, page, or all-call. Trigger pre-programmed text, or privacy mode.



DUAL COMMANDS

Programmable button modes push/release or push/hold accommodate up to two extensions or phone numbers.



SIP INTEGRATION

Enable SIP calls. Dial out pre-programmed internal extensions and external phone numbers.



NOTIFICATION

Trigger alerts that activate other devices, such as a strobe or electronic lock.



SOFTWARE

ClockWise Campus software included. Compatible with approved third-party software.

Solutions	Additional Features	Compatible IP Devices	Accessories
<ul style="list-style-type: none"> • Paging • Intercom • Emergency notification 	<ul style="list-style-type: none"> • Built-in web server 	<ul style="list-style-type: none"> • HD IP Display <ul style="list-style-type: none"> • IPCSHD-MB • IP Speaker with HD Display <ul style="list-style-type: none"> • IPSWDHD-MW • Large Signboard <ul style="list-style-type: none"> • IPSIGNL-RWB • Zone Controller <ul style="list-style-type: none"> • ZONEC2 	<ul style="list-style-type: none"> • Standard junction box required for mounting (not included).

Dimensions

(Dimensions are subject to change)

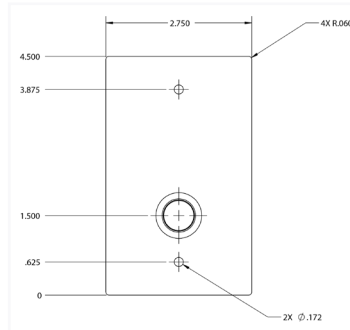

Front

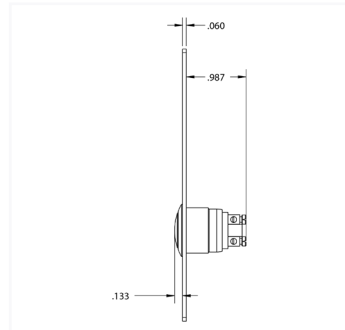

Side

Specifications

Due to continual product development, specifications are subject to change without notice.

Faceplate Material	16-gauge brushed stainless steel
Electrical Life	200,000 cycles
Rating	2a@48V DC
Switch Function	Momentary ON
Operating Temperature	-4° TO 131° F (-20° TO 50° C)
Circuit	SPST
Installation Depth	1" (25.4 mm)
Dimensions	Plate: 2.75" W 4.5" H
Weight	3.8 oz
Warranty	2 Year Limited

