

**SPEAKER SYSTEM**

**CHR 15**  
**CHR 12**  
**CHR 10**

**CHR 15M**  
**CHR 12M**

**Reference Manual**

# Contents

---

Available documentation.....	2	Connection .....	7
NOTICE .....	3	Installation Examples .....	8
Main Features .....	4	Troubleshooting .....	11
Included Accessories .....	4	Specifications .....	12
Controls and Connectors .....	5	Dimensions .....	13

## Available documentation

---

The following documents are available for this product.

- **Owner’s manual (included in the product package)**

Describes safety precautions, installation, and implementation of this product. To learn how to use the product properly and safely, please read this manual before use.

- **Reference manual (this document)**

Explains all features of this product.

You can download each document from the Yamaha website. Please refer to them as necessary.

<https://download.yamaha.com/>

The precautions and other matters of concern are classified in this manual as follows.

-  **CAUTION**

This content indicates “risk of injury.”

- **NOTICE**

Matters that must be observed to avoid product breakdown, damage or malfunction.

- **NOTE**

Points of note when using this product, limitations in functionality, and supplementary information that’s useful to know.

# NOTICE

---

To avoid the possibility of malfunction/damage to the product or damage to other property, follow the notices below.

## ■ Handling and maintenance

- Do not expose the product to excessive dust or vibration, or extreme cold or heat, in order to prevent the possibility of panel disfiguration, unstable operation, or damage to the internal components.
- Do not touch the speaker driver unit, since it might cause malfunction.
- Be sure to observe the amplifier's rated load impedance (see page 12), particularly when connecting speakers in parallel. Connecting an impedance load outside the amplifier's rated range can damage the amplifier.
- Air blowing out of the bass reflex ports (hole or holes at the front) is normal, and often occurs when the speaker is handling program material with heavy bass content.
- When cleaning the product, use a dry and soft cloth. Do not use sodium hypochlorite solution, ethanol, paint thinners, solvents, cleaning fluids, or chemical-impregnated wiping cloths, since this might cause alteration or discoloration.
- Do not place the speaker face down.

## ■ Protective Circuit

- All full-range loudspeakers are fitted with a self-resetting poly switch that protects the high-frequency driver from damage caused by excessive power. If a loudspeaker cabinet loses high-frequency output, immediately remove power from the power amplifier and wait for two to three minutes. This should be long enough to allow the poly switch to reset. Reapply power and check the performance of the high-frequency driver before continuing, with the power reduced to a level that does not cause the poly switch to interrupt the signal.

## Information

### ■ About this manual

- The illustrations as shown in this manual are for instructional purposes only.
- The company names and product names in this manual are the trademarks or registered trademarks of their respective companies.
- The example illustrations used in this manual are taken from the CHR15, if not otherwise specified.

## Main Features

---

- This is a high-quality speaker unit, with smooth directional characteristics, and has built-in ports that reduce wind roar in order to achieve a high-resolution sound.
- Delivers high sound pressure due to the unit's high-input tolerance and exceptional reliability from protection circuitry.
- Features a comprehensive lineup optimized for a variety of applications. The CHR15 is ideal for use as a main speaker delivering powerful sound, while the CHR15M and CHR12M feature a sound character optimized for monitoring and are ideal for use as compact floor monitors. The CHR12 and CHR10 are each equipped with a rotatable horn, and can be set up vertically or horizontally in a fixed installation by using compatible brackets.
- The naturally textured wood cabinet of the CHR speakers feature a durable coating with high scratch resistance that protects the cabinet surface from impact during transport, installation, and removal.
- Equipped with speakON Input/output connectors (parallel connection is possible).
- Installable with eye bolt rigging and brackets (CHR15/CHR12/CHR10).

## Included Accessories

---

- Owner's manual ×1

# Controls and Connectors

Rear (CHR15)

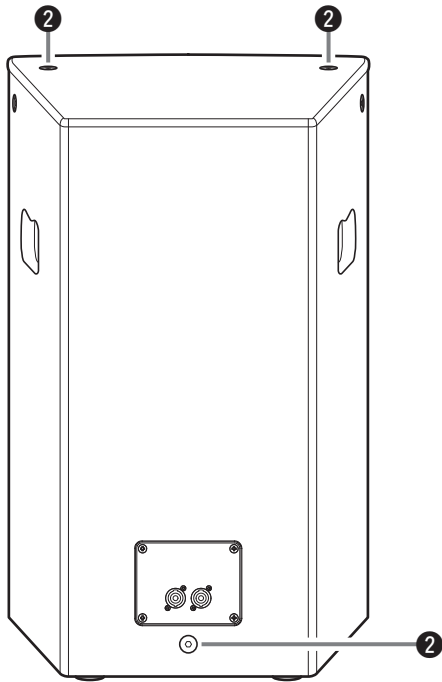

Rear (CHR12)

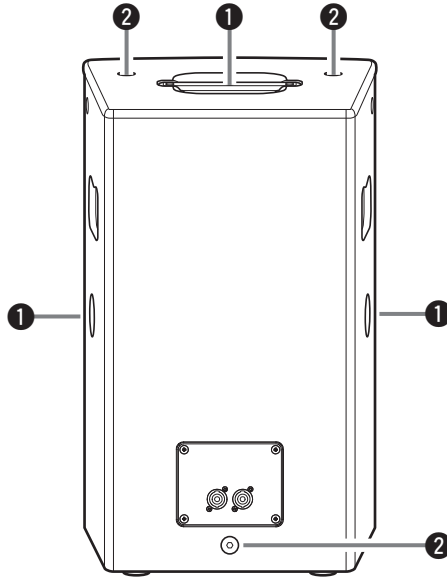

Rear (CHR10)

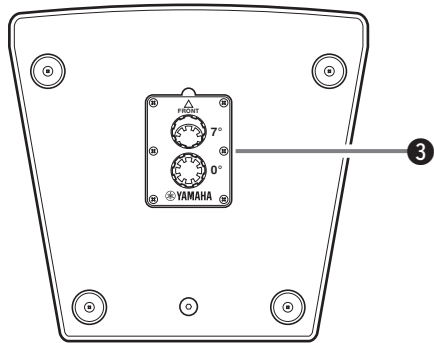
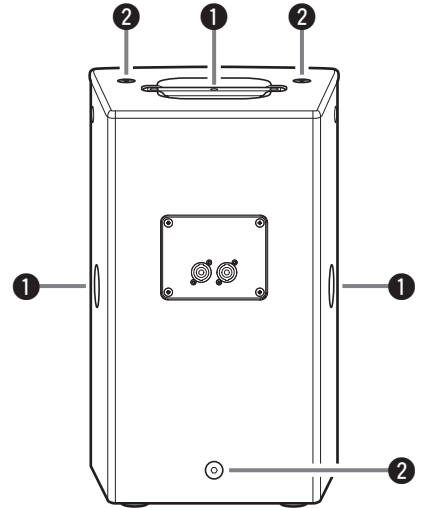

Bottom

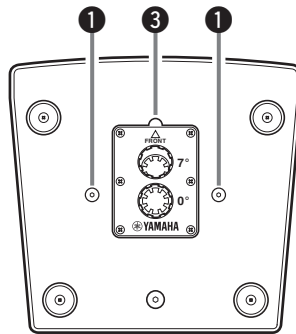

Bottom

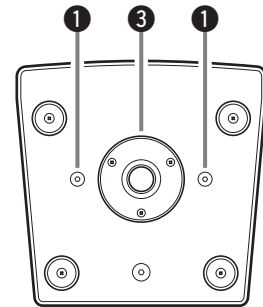

Bottom

Side (CHR15M, CHR12M)

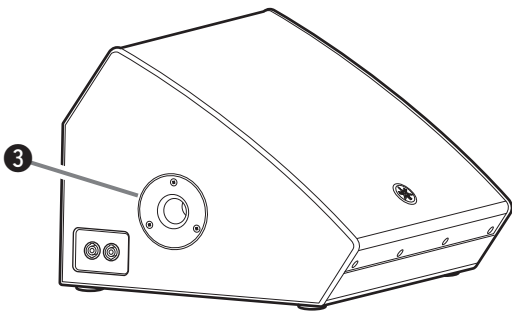

**1 Screw holes for U-bracket M8 (CHR12, CHR10)**

For installation using separately sold U-brackets.

**2 Screw holes for eye bolts M10 (CHR15, CHR12, CHR10)**

For installation using commercially available eye bolts (M10).

**3 Pole socket**

This socket is compatible with commercially available speaker stands and speaker poles of 35 mm diameter.

**Tiltable pole socket (CHR15, CHR12)**

This mount has two pole sockets. You can choose the angle of the speaker so that it is positioned vertically or tilting down toward the floor by 7 degrees.

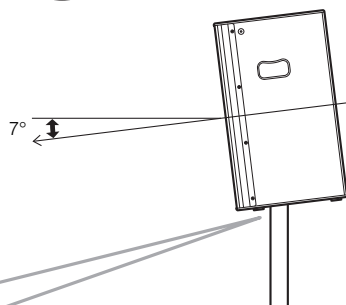
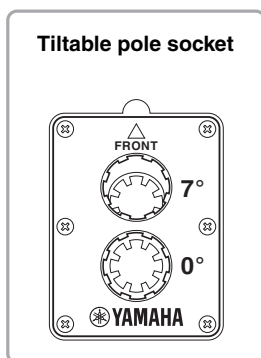

## speakON connectors

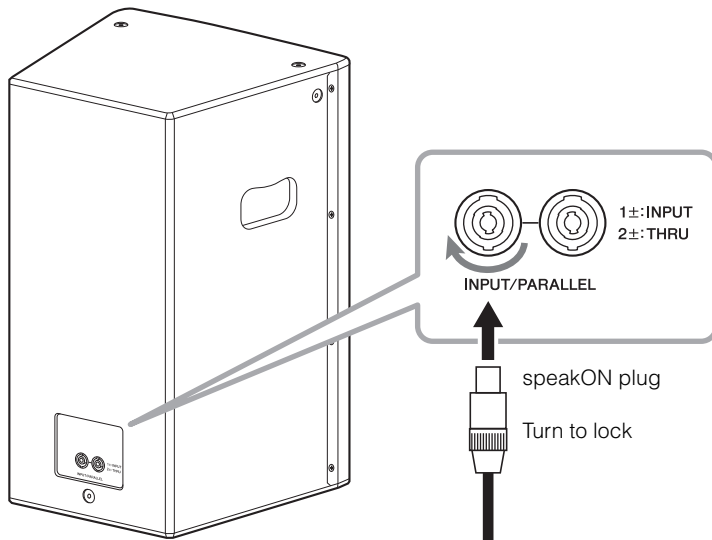

These are speakON connectors (NEUTRIK NL4) for connection to a power amplifier or a powered mixer using a speaker cable. Use only NEUTRIK NL4 plugs to connect speakON connectors.



### CAUTION

Use cables specially designed for speakers. Use of other types of cables may result in fire.

### Rear panel (CHR15, CHR12, CHR10)

The CHR15M and CHR12M each feature a total of three speakON connectors on the side panels.

On the pole socket side

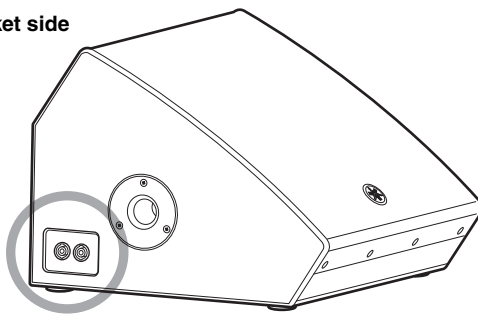

On the handle side

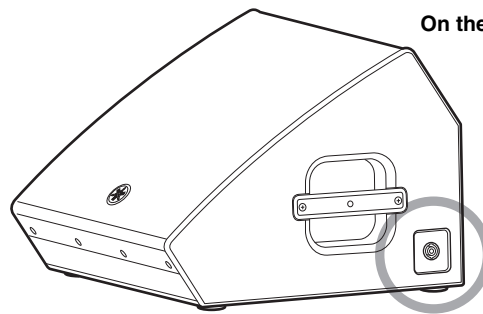

### Side panels (CHR15M, CHR12M)

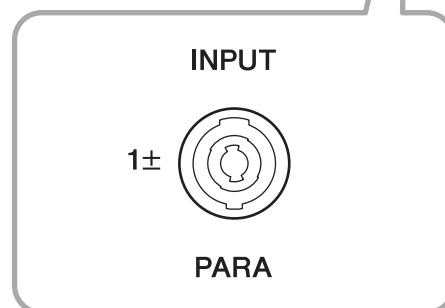
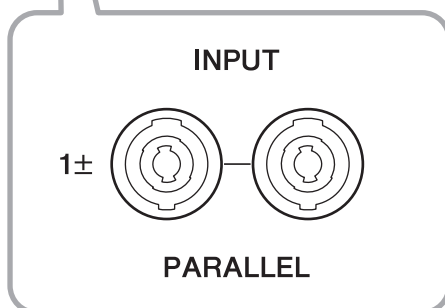

# Connection

## Wiring

Be sure to wire the plugs as shown below.

### ■ NEUTRIK speakON plug (NL4)

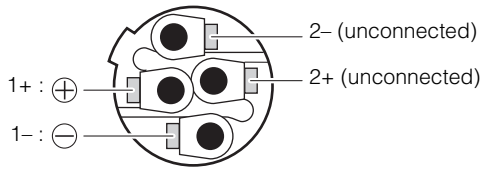

## Parallel connection of speakers

speakON connectors are connected inside in parallel. The first CHR receives the signal from an amplifier (such as a power amplifier, a powered mixer, etc.) through one of the speakON connectors, and routes the signal to the second CHR from another speakON connector.

When connecting CHRs in parallel, be sure to check the load impedance the amplifier can drive. The nominal impedance of one CHR is eight ohms. Therefore, the total impedance of two CHRs connected in parallel is four ohms. In this case, the amplifier must be able to drive less than a four ohm load impedance.

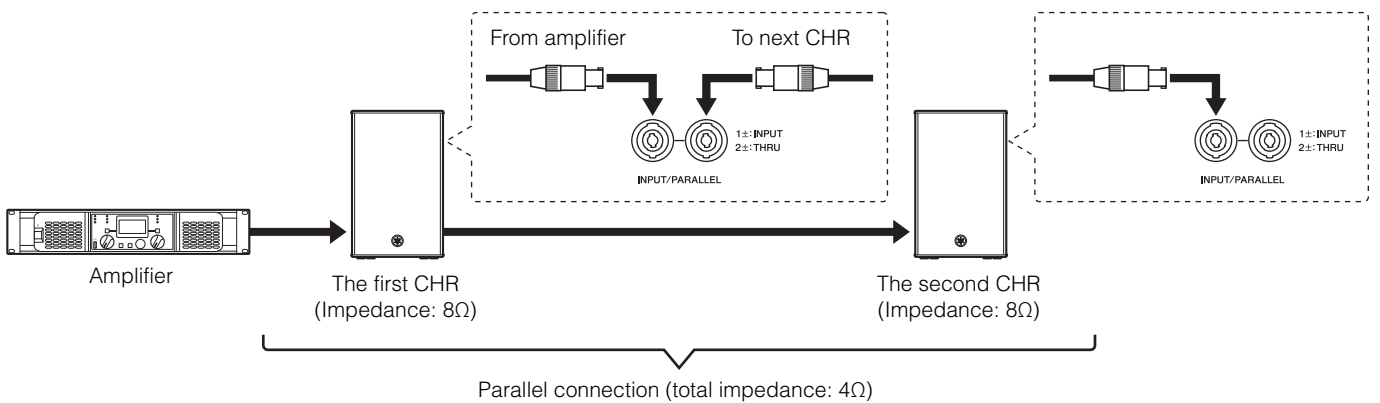

### ■ Invalid connection

Do not connect the input from the amplifier to both the speakON connectors simultaneously. This creates a dangerous short circuit.

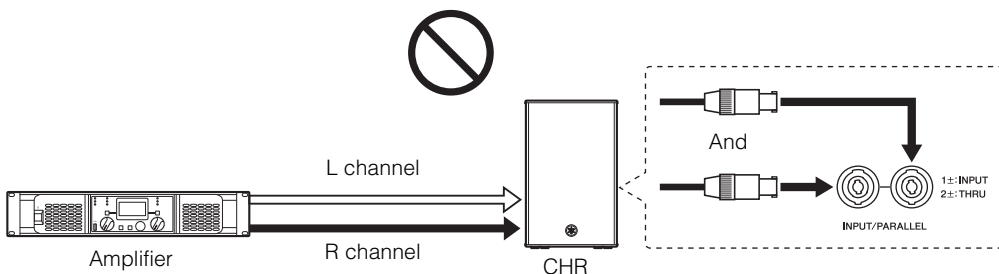

# Installation Examples



## CAUTION

- Before doing any installation or construction work, consult with your Yamaha dealer.
- The installation should be checked thoroughly at regular intervals. Some fittings may deteriorate over extended periods of time due to wear and/or corrosion.
- Make sure that the wires, wall, ceiling, and mounting hardware are strong enough to support the weight of the speaker.
- Be sure to take precautionary measures using safety wire to prevent the speaker from falling.
- When attaching the safety wire to the wall, install it higher than the wire's attachment point on the speaker, with as little slack as possible. If the wire is too long, and the speaker happens to fall, the wire may snap as a result of too much strain.
- Be sure to use eye bolts that comply with standards and safety regulations in your area.

## NOTE

Safety wires can be attached to the screw holes for eye bolts and to the screw holes for the U-bracket (CHR12, CHR10) located at the center of the handle. The illustration below is an example of using the U-bracket.

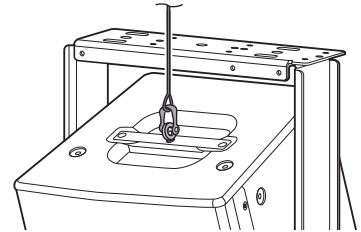

Yamaha cannot be held responsible for damage or injury caused by insufficient strength of the support structure or improper installation.

## Suspended Installation Using Eye Bolts (CHR15, CHR12, CHR10)

Attach commercially available long eye bolts (30–50 mm in length) to the screw holes located at the top (two locations) and on the lower rear (one location). The screw diameter is M10. Keep in mind that you will need to use two points on the top to suspend the unit.

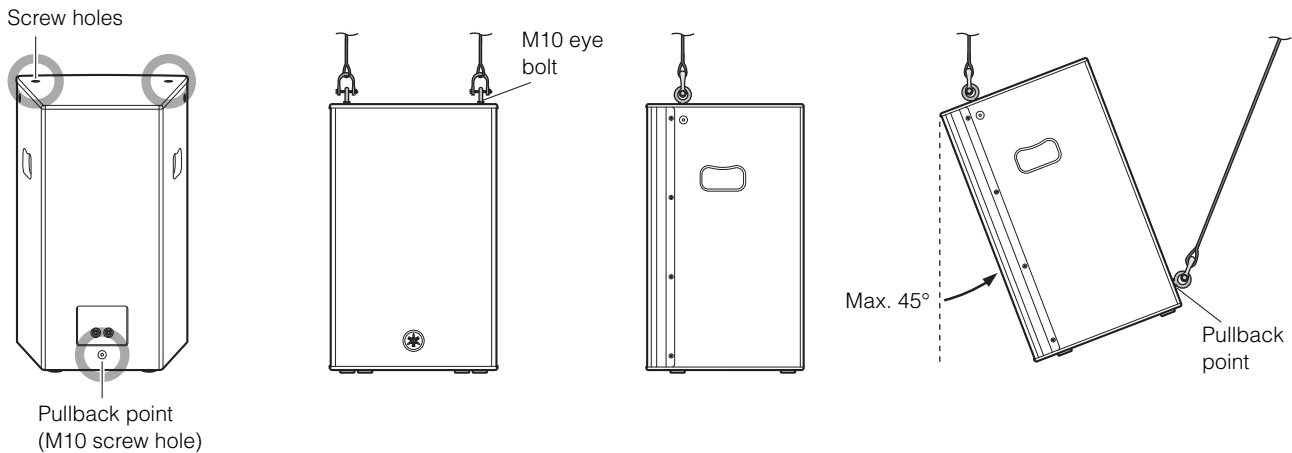

### ■ Securing the eye bolts

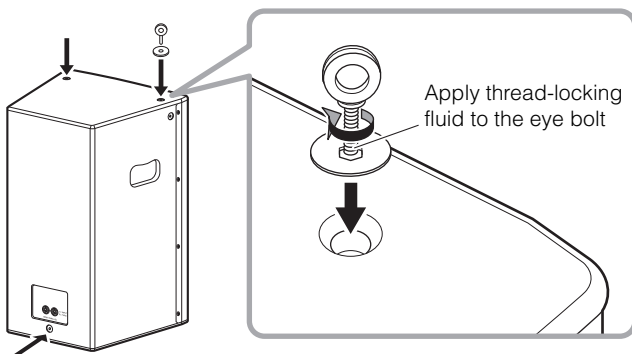

Remove the flat-head screws that were installed when the unit was shipped from the factory, and then insert the eye bolts through the washers when attaching them.

## NOTE

The screw holes for eye bolts go through the cabinet wall. When not using eye bolts, tighten the flat-head screws in order to prevent air leaks.



### ■ Suspension angle

The strength of an eye bolt differs depending on the suspension angle. Be sure to use eye bolts within a range of 0 to 45 degrees of perpendicular (as shown).

**Correct:** Within 45° of perpendicular



**Incorrect:** Do not suspend the eye bolts as shown in the illustrations below.



Prohibited

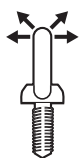

Prohibited

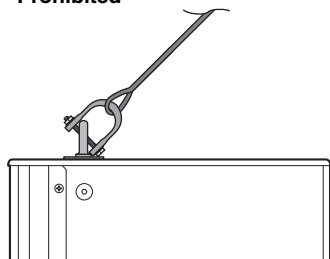

Prohibited

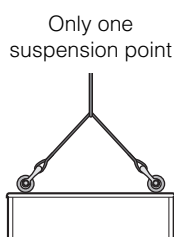

Prohibited

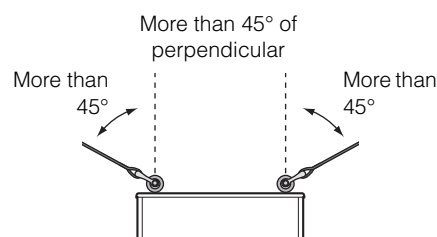

### Installation Using a Dedicated U-bracket (CHR12, CHR10)

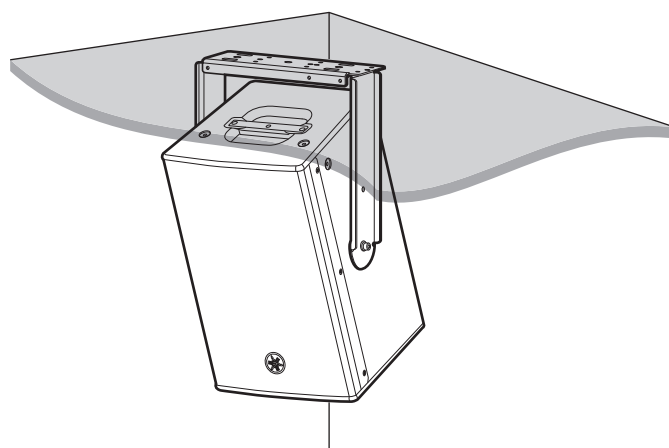
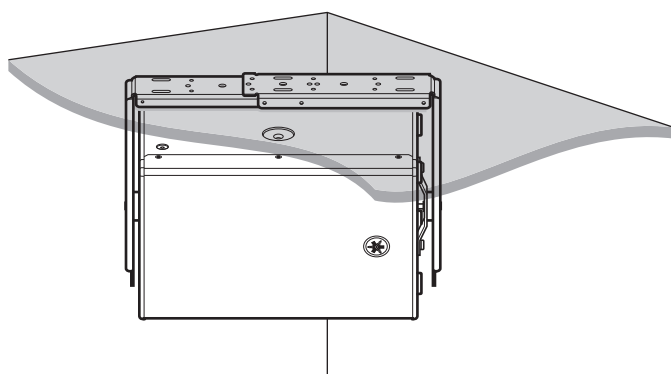

CHR12 and CHR10 can be neatly installed on a ceiling or a wall, either horizontally or vertically, using the separately sold Yamaha UB-DXRDR12 and UB-DXRDR10 U-bracket respectively. For instructions on installing the U-bracket, refer to the manual for the UB-DXRDR12 and UB-DXRDR10.

**NOTE**

You can use the U-bracket in combination with optional brackets sold separately. For more information, visit the following Yamaha Pro Audio website.

<https://www.yamahaproaudio.com/>

In addition, the CHR12 and CHR10 feature a rotatable horn (90 degrees). When they are shipped from the factory, the speaker directivity is set wide horizontally and narrow vertically, assuming that the speaker is installed vertically. If you are planning to install the speaker in a horizontal orientation, we recommend that you change the directivity by changing the horn orientation.

## Rotatable Horn (CHR12, CHR10)

- Using a No. 2 Phillips head screwdriver, remove all fixing screws on the grille, and then remove the grille from the speaker.

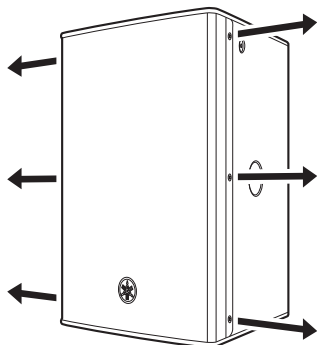

- Using a No. 2 Phillips head screwdriver, remove all screws installed on the horn and then pull the horn out from the speaker.

**NOTE**

While removing the screws with the Phillips head screwdriver, do not apply too much pressure onto the screws. Otherwise, the nuts inside the cabinet may fall off.

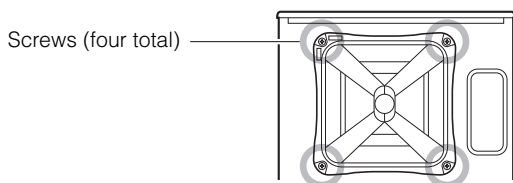

- Rotate the horn 90 degrees, and re-install the horn to the speaker, reversing the steps above.

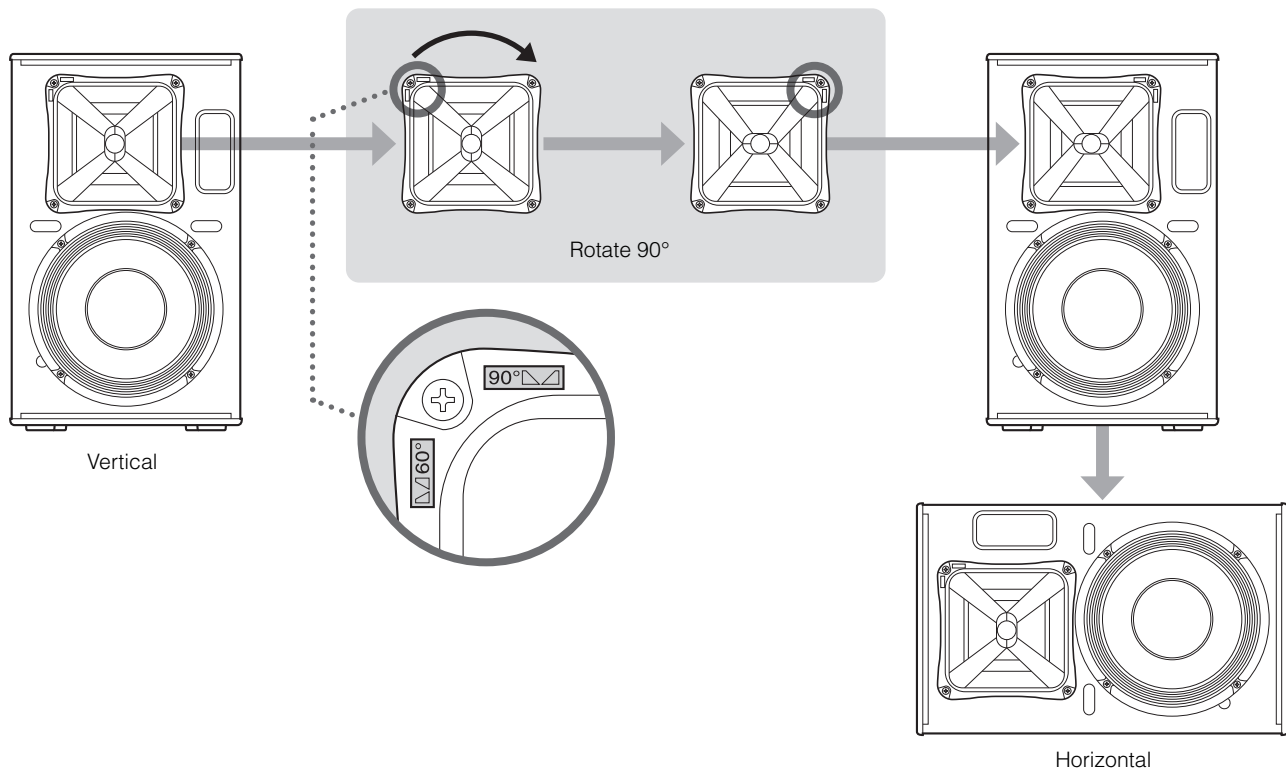

# Troubleshooting

Symptom	Possible causes	Possible solution
No sound.	The cable is not connected properly.	<ul style="list-style-type: none"> <li>• Connect the cable all the way in so that it is firmly in place.</li> <li>• Connect to “1+” and “1-” and turn the plug to be locked.</li> </ul>
Howling sound (feedback).	A microphone is directed toward the speaker.	Aim the speaker away from the area where the microphone picks up sound.
	The sound is amplified too much.	Lower the volume of the input device and locate the microphone closer to the sound source.
The amplifier shuts down.	<p>The total impedance of the speakers is less than the minimum load impedance of the amplifier.</p> <p>Example: More than two speakers (eight ohms) are connected to a power amplifier, the load impedance of which is six ohms.</p>	Check the minimum load impedance of the power amplifier, and lower the number of speakers connected in parallel not to be less than the impedance.
High frequency range is attenuated.	The protection circuit is operating in the HF unit.	Refer to “Protective Circuit” in the NOTICE (page 3).

If any specific problem should persist, please contact your Yamaha dealer.

# Specifications

General specifications		CHR15M	CHR12M	CHR15	CHR12	CHR10	
System Type		2-way Speaker, Bass-reflex Type					
Frequency Range (-10 dB)		58 Hz-20 kHz	61 Hz-20 kHz	49 Hz-20 kHz	54 Hz-20 kHz	55 Hz-20 kHz	
Coverage Angle		H65° × V75°	H90° × V90°	H90° × V60°	H90° × V60° (Rotatable)	H90° × V60° (Rotatable)	
Maximum SPL (Calculated, 1 m)		125 dB SPL	123 dB SPL	125 dB SPL	124 dB SPL	122 dB SPL	
Crossover Frequency		2.0 kHz	1.5 kHz	2.0 kHz	2.0 kHz	2.5 kHz	
Nominal Impedance		8 Ω	8 Ω	8 Ω	8 Ω	8 Ω	
Power Rating (IEC noise)	NOISE	275 W	250 W	250 W	250 W	175 W	
	PGM	550 W	500 W	500 W	500 W	350 W	
	MAX	1100 W	1000 W	1000 W	1000 W	700 W	
Sensitivity (1 W, 1 m)		95 dB SPL	93 dB SPL	95 dB SPL	94 dB SPL	93 dB SPL	
Transducer	LF	Diameter	15" Cone	12" Cone	15" Cone	12" Cone	10" Cone
		Voice coil	3"	2.5"	2.5"	2.5"	2"
		Magnet	Ferrite	Ferrite	Ferrite	Ferrite	Ferrite
	HF	Diaphragm	1.75"	1.75"	1.4"		
		Type	1" Throat Compression Driver, Coaxial	1" Throat Compression Driver, Coaxial	1" Throat Compression Driver		
		Magnet	Ferrite	Ferrite	Ferrite		

Enclosure	CHR15M	CHR12M	CHR15	CHR12	CHR10
Material, Finish, Color	Plywood, Durable polyurea coating, Black				
Floor Monitor Angle	57°	57°	—	—	—
Dimensions (W × H × D, with rubber feet)	642 × 369 × 505 mm (25.3" × 14.5" × 18.9")	500 × 343 × 454 mm (19.7" × 13.5" × 17.9")	432 × 692 × 405 mm (17.0" × 27.2" × 15.9")	359 × 578 × 340 mm (14.1" × 22.8" × 13.4")	305 × 494 × 300 mm (12.0" × 19.5" × 11.8")
Net Weight	21.3 kg (47.0 lbs)	15.6 kg (34.4 lbs)	22.0 kg (48.5 lbs)	17.1 kg (37.7 lbs)	13.7 kg (30.2 lbs)
Grille	Matte black powder coated perforated steel grille with cloth mesh lining, t=2.0		Matte black powder coated perforated steel grille, t=1.5		
Handles	Side × 1	Side × 1	Side × 2	Top × 1, Side × 2	Top × 1
Pole Socket	35 mm × 1	35 mm × 1	35 mm × 2 (0 and -7 degree)	35 mm × 2 (0 and -7 degree)	35 mm × 1
Rigging Points	—	—	Top × 2, Rear × 1 (Fit for M10 × 30-50 mm Eyebolts)	Top × 2, Rear × 1 (Fit for M10 × 30-50 mm Eyebolts), Bottom × 2, Side × 2 (Fit for M8 × 55 mm UB-DXRDR12)	Top × 2, Rear × 1 (Fit for M10 × 30-50 mm Eyebolts), Bottom × 2, Side × 2 (Fit for M8 × 55 mm UB-DXRDR10)
Options	—	—	—	UB-DXRDR12	UB-DXRDR10
Connectors	SpeakON NL4MP × 3 (parallel connected)	SpeakON NL4MP × 3 (parallel connected)	SpeakON NL4MP × 2 (parallel connected)		

\* The contents of this manual apply to the latest specifications as of the publishing date. To obtain the latest manual, access the Yamaha website then download the manual file.

# Dimensions

## ■ CHR15

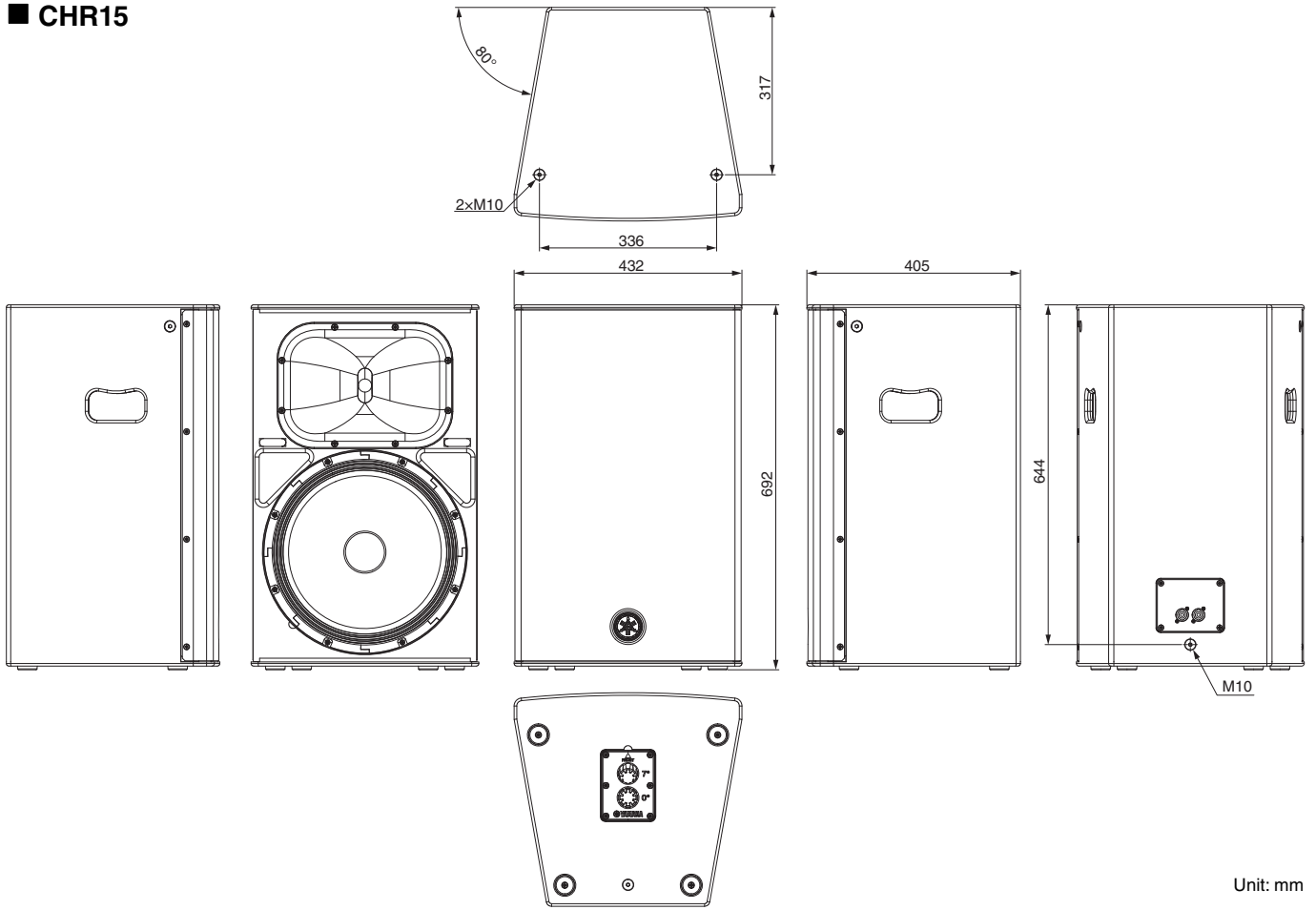

Unit: mm

## ■ CHR12

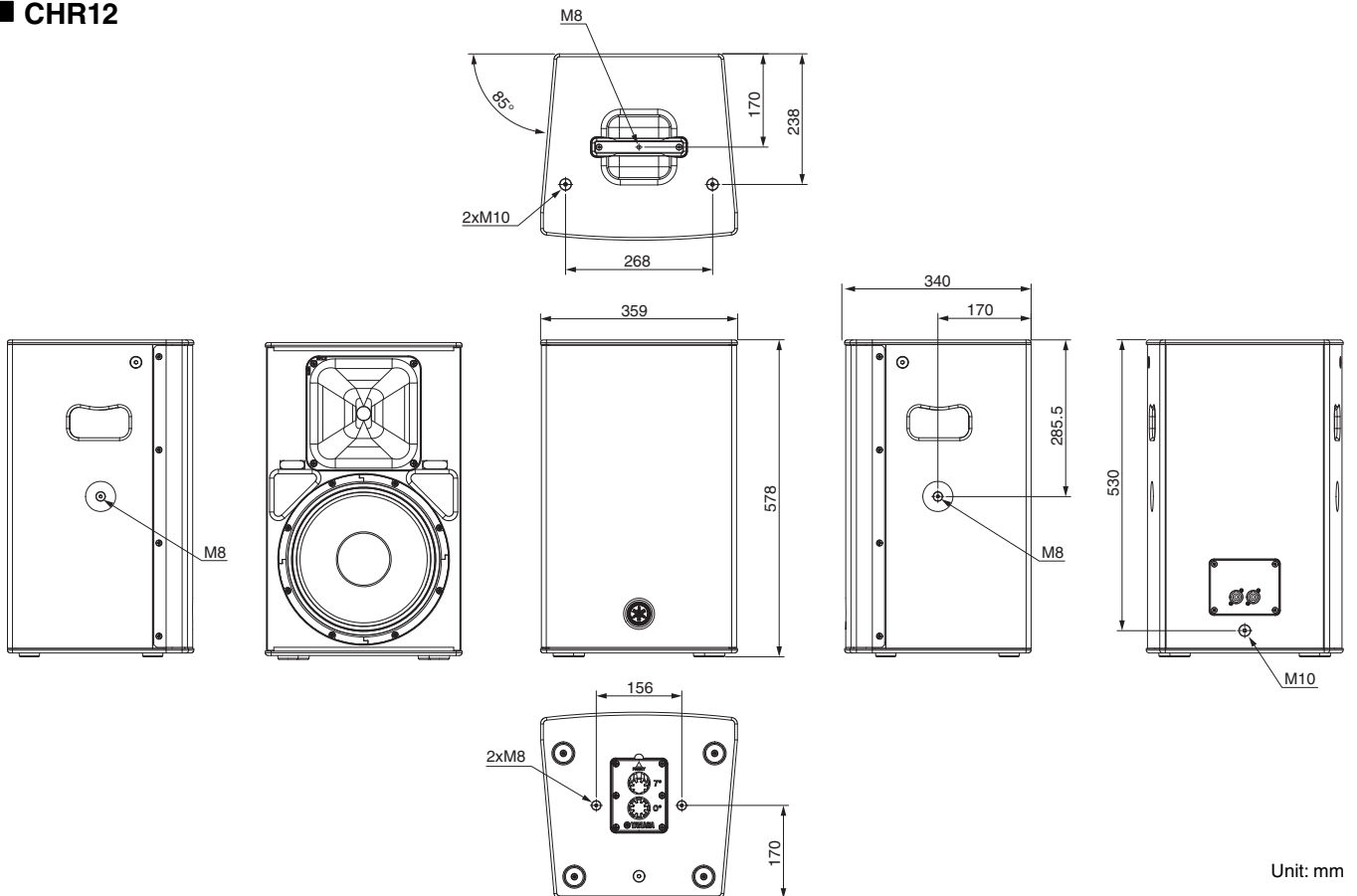

Unit: mm

■ CHR10

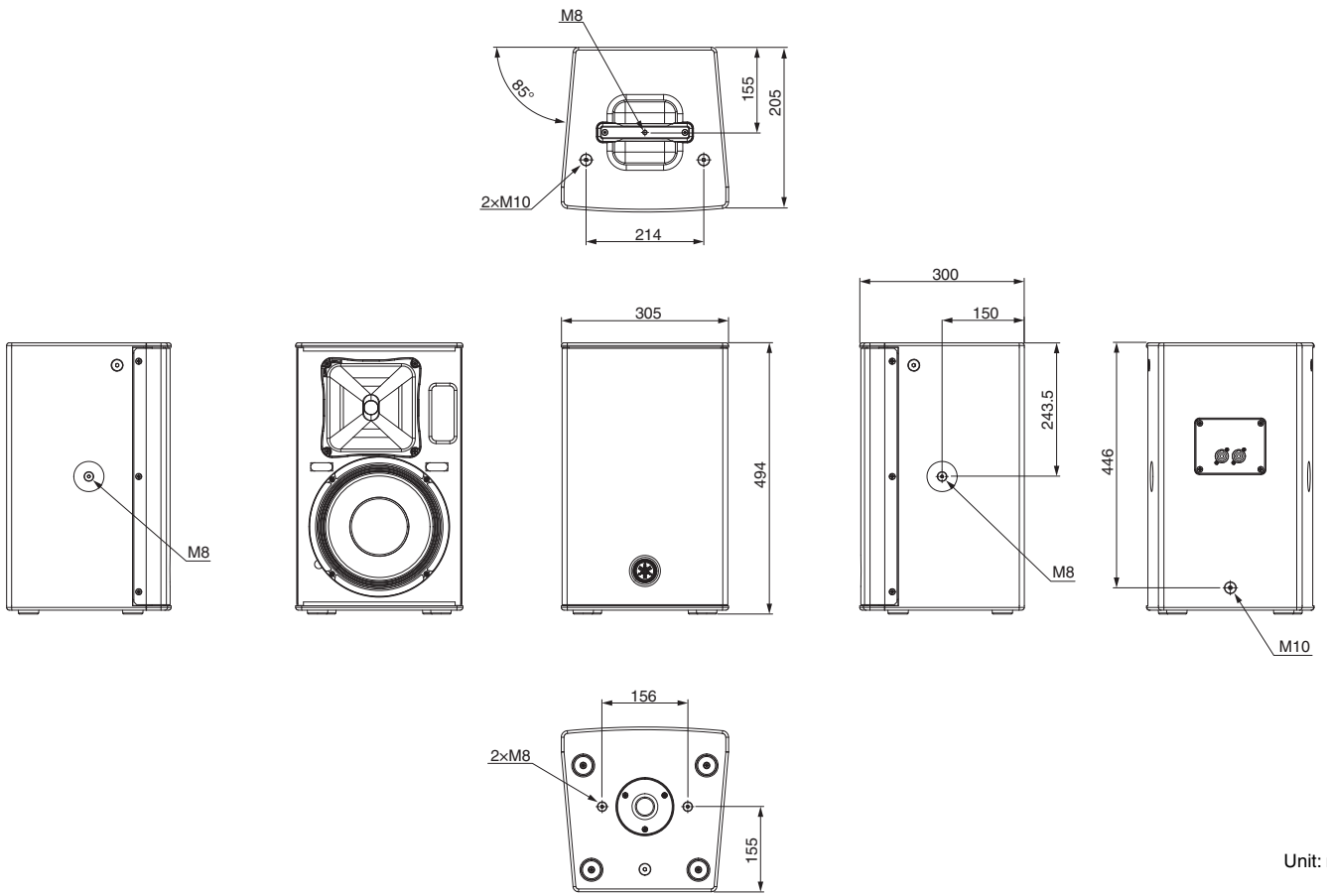

Unit: mm

■ CHR15M

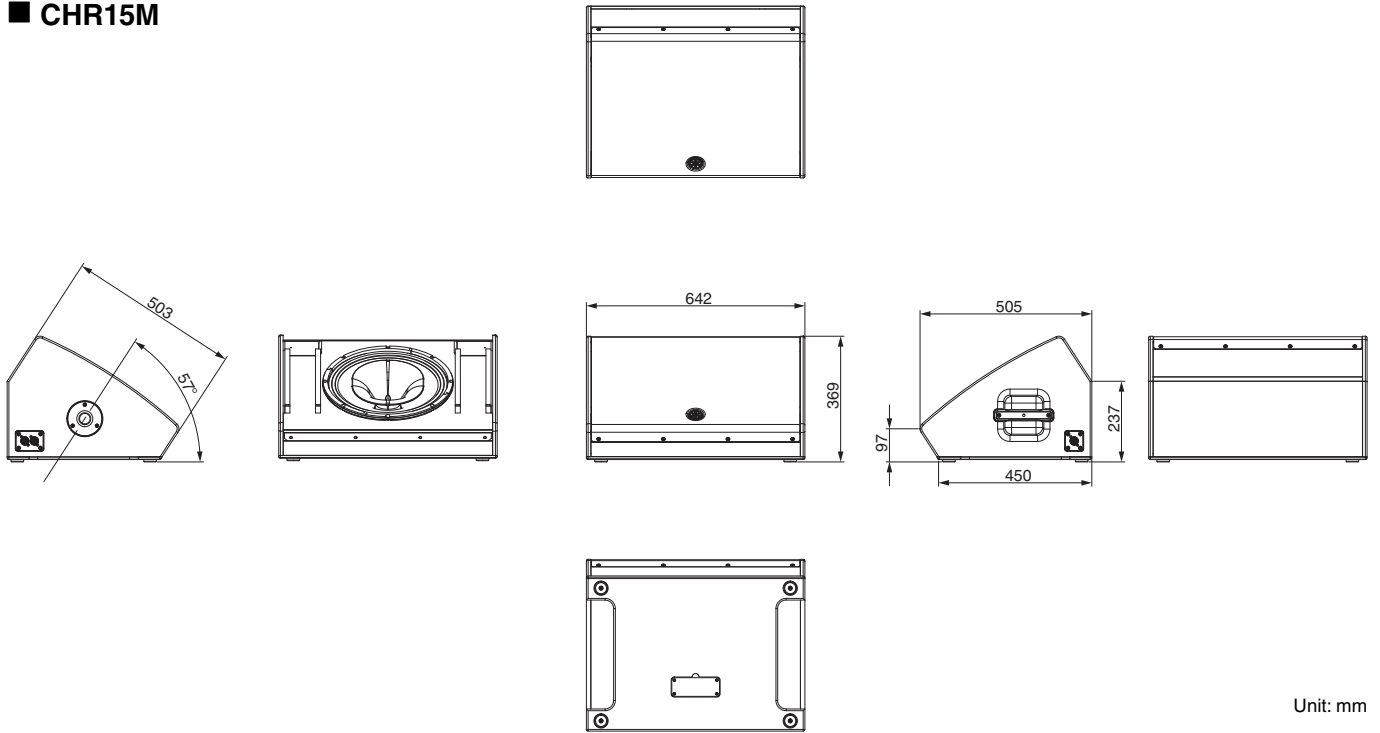

Unit: mm

■ CHR12M

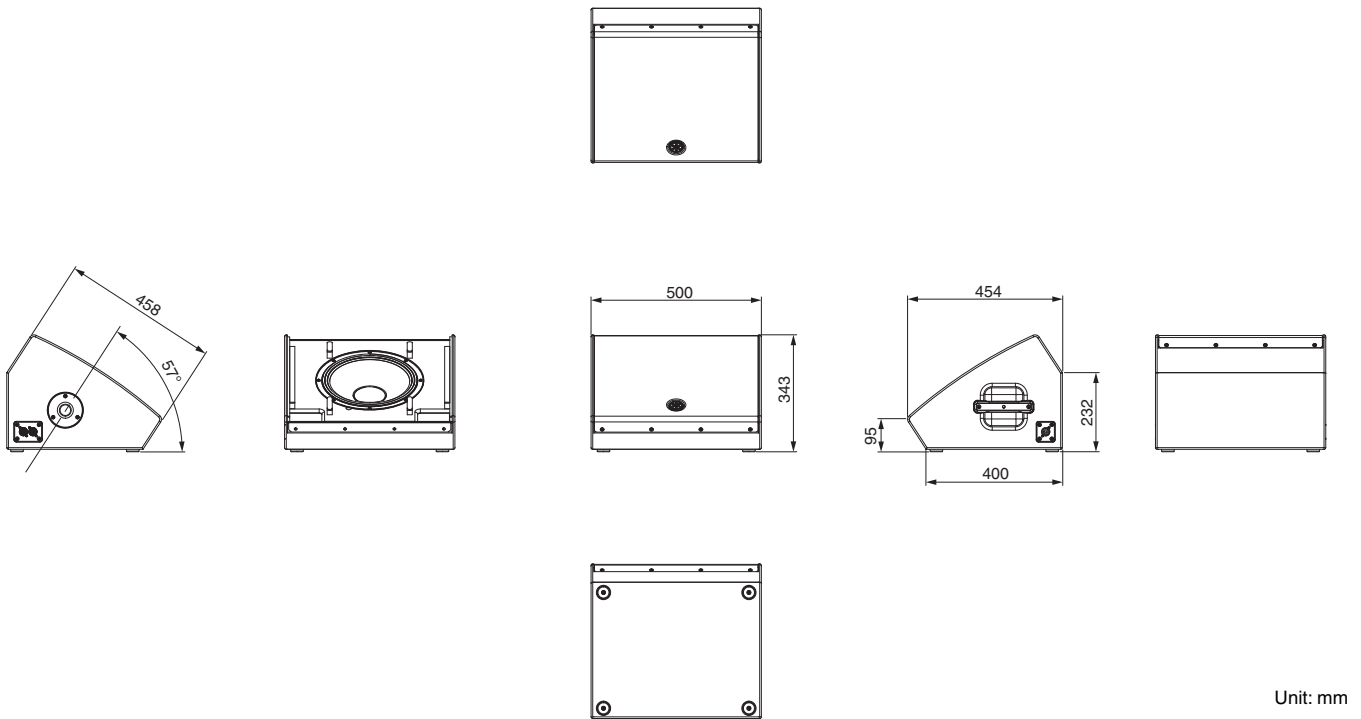

Unit: mm

Yamaha Pro Audio global website  
<https://www.yamahaproaudio.com/>

Yamaha Downloads  
<https://download.yamaha.com/>