

# BANJO PICKUP

Installation Manual

*C.R. Bagby*

## STEP 1. BRIDGE/PICKUP INSTALLATION

Before removing the existing bridge, it is a good idea to put a small pencil mark on the head, just behind the backside of the feet. This will work as a reference point for the new bridge to ensure proper intonation.

Loosen the strings enough to remove the old bridge. Place the LR Baggs bridge/pickup on the banjo head using the pencil marks as a locating guide (**see figure 1**). Install the bridge with the wire facing the tailpiece and bring the strings back up to pitch.

**NOTE:** This is a good opportunity to check and, if needed, adjust the tension of the banjo head. Over time, banjo heads can become loose, which can cause the bridge to warp and can damage the pickup.

*fig. 1*

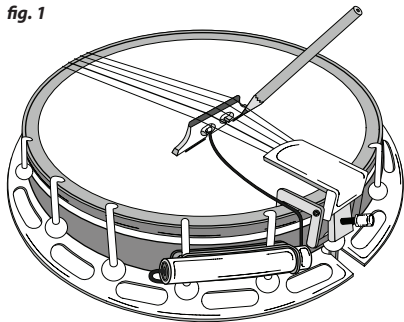

## STEP 2. MOUNTING HARDWARE INSTALLATION

First, remove the jack from the L-bracket by unscrewing the end cap. Next, unscrew the L-bracket from the mounting plate by using the hex key.

**NOTE:** The screws are attached to the L-bracket with E-clips, therefore you will need to loosen each screw a little at a time so they remain aligned with the threaded holes in the mounting plate.

With the banjo on its back, place the mounting plate behind two of the tensioning rods with the threaded holes between the rods (**see figure 2**).

We recommend mounting on the left side of the tailpiece. Hold the L-bracket up to the mounting plate and secure in place with the hex screws (**see figure 3**). Once again, adjust each screw a little at a time until the bracket is set in place.

*fig. 2*

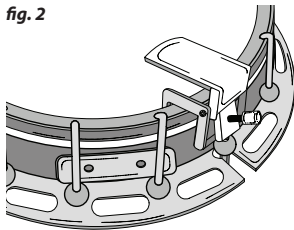

*fig. 3*

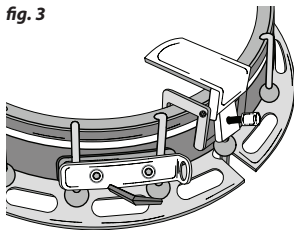

### STEP 3. JACK HARDWARE INSTALLATION

Insert the end of the jack through the hole in the L-bracket (**see figure 4**), and hold in place while you thread on the end cap (**see figure 5**). Hold the barrel with one hand as you grip the end cap with your other hand, using the round gripping pad provided, and tighten until each side is flush with the L-bracket. Hand tight is sufficient, no tools required. Tie down loose wires with the provided zip ties and wire clips.

### PERFORMANCE RECOMMENDATION

The Banjo Pickup is a high impedance, passive transducer and will perform best with an external, acoustic preamp.

*fig. 4*

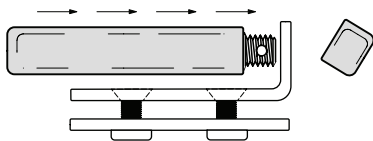

*fig. 5*



## **PACKAGE CONTENTS**

Bridge/pickup

Jack and mounting hardware

Hex key

Gripping pad

Two zip ties

Two wire clips

**REGISTER THIS PRODUCT**  
ONLINE AT [LRBAGGS.COM](http://LRBAGGS.COM)

*L.R. Baggs*